

TECHNICAL & SERVICE MANUAL V4.1

—DC-INVERTER AIR CONDITIONERS

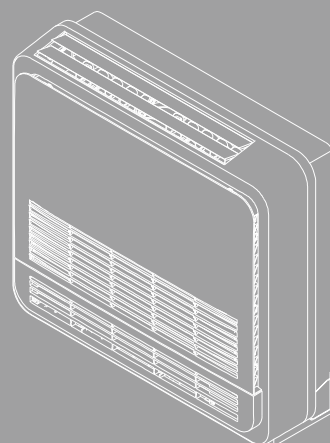
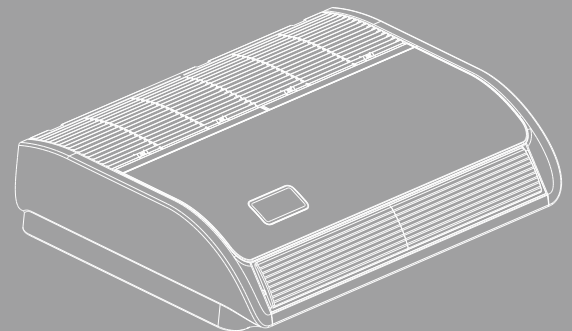
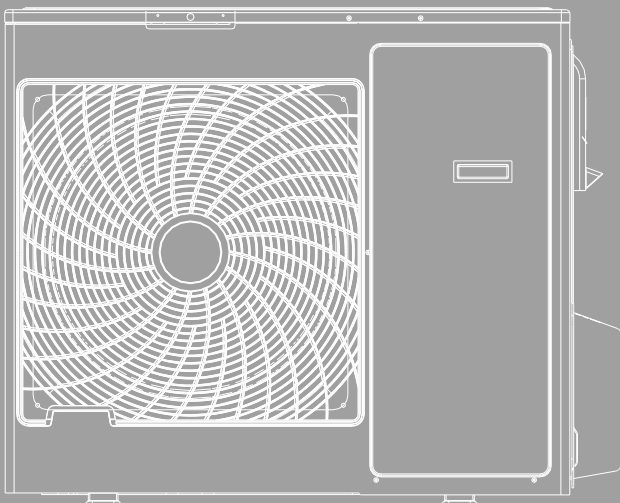
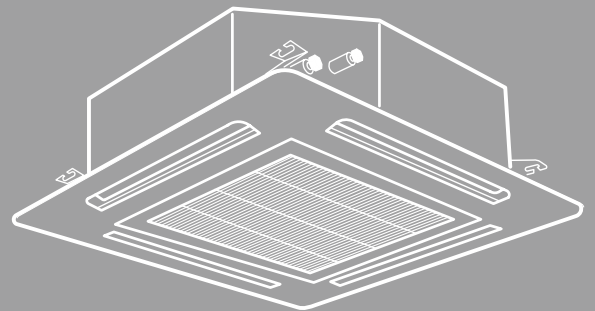
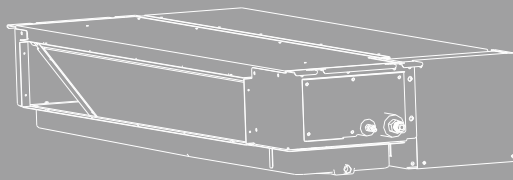

Models

Heat pump type

< Indoor Units >

Ducted

ADT-09UX4RBL4
ADT-12UX4RBL4
ADT-18UX4RCL4
AUD-24UX4RCL4
AUD-30UX4RDH4
AUD-36UX4RDH4
AUD-42UX4RHH4
AUD-48UX4RHH4
AUD-60UX4RHH4

Cassette

ACT-09UR4RCA4
ACT-12UR4RCA4
ACT-18UR4RCA4
AUC-24UR4RGB4
AUC-30UR4RGB4
AUC-36UR4RGB4
AUC-42UR4RHB4
AUC-48UR4RHB4
AUC-60UR4RHB4

Ceiling & Floor

AVT-18UR4RA4
AUV-24UR4RA4
AUV-30UR4RB4
AUV-36UR4RB4
AUV-42UR4RC4
AUV-48UR4RC4
AUV-60UR4RC4

Console

AKT-09UR4RK4
AKT-12UR4RK4
AKT-18UR4RK4

< Outdoor Units >

AUW-09U4RR4
AUW-12U4RS4
AUW-18U4RS4
AUW-24U4RF4
AUW-30U4RA4
AUW-36U4RA4
AUW-42U6RT4
AUW-48U6RP4
AUW-60U6RP4

NOTE:

Heating function is not available for cooling only models.

SAFETY SUMMARY

IMPORTANT NOTICE

- We pursue a policy of continuing improvement in design and performance of products. The right is therefore reserved to vary specifications without notice.
- We cannot anticipate every possible circumstance that might involve a potential hazard.
- This air conditioner is designed for standard air conditioning only. Do not use this air conditioner for other purposes such as drying clothes, refrigerating foods or for any other cooling or heating process. Do not let the air-out face animals or plants, it might have an adverse effect on it.
- The installer and system specialist shall secure safety against leakage according to local regulations or standards.
- Signal words (DANGER, WARNING and CAUTION) are used to identify levels of hazard seriousness. Definitions for identifying hazard levels are provided below with their respective signal words.

▲ DANGER

: Immediate hazards which WILL result in severe personal injury or death.

▲ WARNING

: Hazards or unsafe practices which COULD result in severe personal injury or death.

▲ CAUTION

: Hazards or unsafe practices which COULD result in minor personal injury or product or property damage.

NOTE

: Useful information for operation and/or maintenance.

- Installation should be performed by the dealer or another professional personnel. Improper installation may cause water leakage, electrical shock, or fire.

▲ DANGER

- Do not perform installation work, refrigerant piping work, drain piping and electrical wiring connection without referring to our installation manual. If the instructions are not followed, it may result in a water leakage, electric shock or a fire.
- Use refrigerant R32 in the refrigerant cycle.
- Do not pour water into the indoor or outdoor unit. These products are equipped with electrical parts. If poured, it will cause a serious electrical shock.
- Do not open the service cover or access panel for the indoor or outdoor units without turning OFF the main power supply.
- Do not touch or adjust safety devices inside the indoor or outdoor units. If these devices are touched or readjusted, it may cause a serious accident.
- Refrigerant leakage can cause difficulty with breathing due to insufficient air. Turn OFF the main switch, extinguish any naked flames and contact your service contractor, if refrigerant leakage occurs.
- Do perform air-tight test. Do not charge oxygen, acetylene or other flammable and poisonous gases into the refrigerant cycle when performing a leakage test or an air-tight test. These types of gases are extremely dangerous and can cause an explosion. It is recommended that nitrogen be used for this test.
- The installer and system specialist shall secure safety against refrigerant leakage according to local regulations or standards.
- Use an ELB (Electric Leakage Breaker). In the event of a fault, there is danger of an electric shock or a fire if it is not used.

▲ WARNING

- Do not use any sprays such as insecticide, lacquer, hair spray or other flammable gases within approximately one (1) meter from the system.

- If circuit breaker or fuse is often activated, stop the system and contact your service contractor.
- Check that the ground wire is securely connected. If the unit is not correctly grounded, it lead electric shock. Do not connect the ground wiring to gas piping, water piping, lightning conductor or ground wiring for telephone.
- Before performing any brazing work, check to ensure that there is no flammable material around. When using refrigerant be sure to wear leather gloves to prevent cold injuries.
- Protect the wires, electrical parts, etc. from rats or other small animals. If not protected, rats may gnaw at unprotected parts and which may lead to a fire.
- Fix the cables securely. External forces on the terminals could lead to a fire.
- Install the air conditioner on a solid base that can support the unit weight. An inadequate base or incomplete installation may cause injury in the event the unit falls off the base. Incomplete connections or clamping may cause terminal overheating or fire.
- Make sure that the outdoor unit is not covered with snow or ice, before operation.

⚠ CAUTION

- Do not step or put any material on the product.
- Do not put any foreign material on the unit or inside the unit.

NOTE

- It is recommended that the room be ventilated every 3 to 4 hours.
- The air conditioner may not work properly under the following circumstances.
The power transformer provides the same power or power as the air conditioner. The electrical equipment is too close to the power supply of the air conditioner. With the sharp change of power consumption and switching action, the power supply of the air conditioner will generate a large induction surge voltage.

CHECKING PRODUCT RECEIVED

- Upon receiving this product, inspect it for any shipping damage. Claims for damage, either apparent or concealed, should be filed immediately with the shipping company.
- Check the model number, electrical characteristics (power supply, voltage and frequency) and accessories to determine if they are correct.
The standard utilization of the unit shall be explained in these instructions.
Therefore, the utilization of the unit other than those indicated in these instructions is not recommended.
Please contact your local agent, as the occasion arises.

☑ • *The figures in this manual are based on the external view of a standard model. Consequently, the shape may differ from that of the air conditioner you have selected.*

Table of Contents

1. General	1
1.1 Features	1
1.2 Product lineup	5
1.3 Nomenclature	5
1.4 Unit installation	6
1.5 Working range	6
1.6 Product appearance	7
2. Specifications	14
2.1 Duct type	14
2.2 Cassette type	18
2.3 Ceiling & Floor type	22
2.4 Console type	26
3. Outlines and dimensions	28
3.1 Indoor units	28
3.2 Outdoor units	35
4. Electrical data	41
5. Capacities and selection data	42
5.1 Capacity characteristic charts	36
5.2 Piping length correction factor	61
5.3 Correction factors according to defrosting operation	63
6. Sound pressure data	64
7. Air flow distribution	75
7.1 Cassette type	75
7.2 Ceiling & Floor type	84
8. ESP (External static pressure) chart (Duct type)	98
9. Refrigerant cycle	107
10. Fresh air intake function	113
11. Wiring diagram	115
11.1 Electrical wiring diagrams	115
11.2 Control board picture	125
11.3 Common wiring	130
12. Field setting	132
12.1 Indoor unit air flow DIP switch	132
12.2 Outdoor unit DIP switch	133
12.3 ESP setting	134
12.4 Indoor unit parameter revision	135
12.5 Running parameter query	137
12.6 Instructions for the function setting of access control, fire protection	140
13. Piping work and refrigerant charge	142
13.1 MAX. length allowed	142
13.2 Oil trap	142
13.3 Air tight test	143
13.4 Additional refrigerant charge	144
14. Installation tools and installation flow chart	145
14.1 Necessary tools and instrument list for installation	145
14.2 Installation flow chart	146
15. Control mode	147
15.1 Indoor unit mode control	147
15.2 Outdoor unit mode control	148
16. Sensor parameter	151
17. Troubleshooting	157
17.1 Trouble guide	157
17.2 Fault codes	164
18. Checking components	170
18.1 Check refrigerant system	173
18.2 Check parts unit	175
19. Disassembly and assembly for compressor and motor	180
20. Control logic description	197

1. GENERAL

1. General

1.1 Features

Duct Type Air Conditioner



Features

- **Save Installation Space**

The indoor unit can be installed inside the ceiling conveniently.
- **Optional Static Pressure**

Optional ESP, a variety of optional installation methods.
- **24-hour Timer ON and OFF**

This Timer can be set to automatically turn the unit on or off within a 24-hour period.
- **Mute Operation**

The excellent fan design enables smooth airflow with minimum noise.
- **Meeting Various Installation Requirements**

The back-air-inlet type should be adopted according to the actual installation space. The unit is also installed with down-air-inlet type and the noise will increase by 5-6dB.
- **Auto re-start from Power Break**

When the power supply is recovered after power break, all presets are still effective and the air-conditioner will run according to the previous setting.
- **Fault Self-diagnose Function**

When there is a problem in the air-conditioner, the microcomputer could diagnose the faults, which can be read from the display and is convenient for maintenance.

1. GENERAL

Cassette Type Air Conditioner



Features

➤ **Save Installation Space**

The indoor unit can be installed inside the ceiling conveniently.

➤ **24-hour Timer ON and OFF**

This Timer can be set to automatically turn the unit on or off within a 24-hour period.

➤ **Mute Operation**

The excellent fan design enables smooth airflow with minimum noise.

➤ **Auto re-start from Power Break**

When the power supply is recovered after power break, all presets are still effective and the air-conditioner will run according to the previous setting.

➤ **Fault Self-diagnose Function**

When there is a problem in the air-conditioner, the microcomputer can diagnose the faults, which can be read from the display and is convenient for maintenance.

1. GENERAL

Ceiling & Floor Air Conditioner



Features

➤ **Save Installation Space**

The indoor unit's height is only 230mm, can be installed inside the ceiling conveniently.

➤ **Flexible Installation Options**

According to the actual installation space, the indoor unit can be installed in the ceiling or on the floor. One unit, two installation method.

➤ **24-hour Timer ON and OFF**

This Timer can be set to automatically turn the unit on or off within a 24-hour period.

➤ **Mute Operation**

The excellent fan design enables smooth airflow with minimum noise.

➤ **Various Refrigerant Pipe Connect Methods**

The refrigerant pipe can be connected from 3 different directions (rear, right, or top).

➤ **Auto re-start from Power Break**

When the power supply is recovered after power break, all presets are still effective and the air-conditioner will run according to the previous setting.

➤ **Fault Self-diagnose Function**

When there is a problem in the air-conditioner, the microcomputer could diagnose the faults, which can be read from the display and is convenient for maintenance.

1. GENERAL

Console Type Air Conditioner

Features

➤ **Flexible Installation Options**

According to the actual installation space, the indoor unit can be installed in any of the three styles. One unit, three installation methods.



➤ **24-hour Timer ON and OFF**

This Timer can be set to automatically turn the unit on or off within a 24-hour period.

➤ **Mute Operation**

The excellent fan enables smooth airflow with minimum noise.

➤ **Various Refrigerant Pipe Connect Methods**

The refrigerant pipe can be connected from 6 different directions. More methods, more conveniently.

➤ **Auto Re-start from Power Break**

When the power supply is recovered after power break, all presets are still effective and the air-conditioner will run according to the previous setting.

➤ **Fault Self-diagnose Function**

When there is a problem in the air-conditioner, the microcomputer can diagnose the faults, which can be read from the display and is convenient for maintenance.

1. GENERAL

1.2 Product lineup

Type \ Model (Btu/h)	9K	12K	18K	24K	30K	36K	42K	48K	60K
Duct	●	●	●	●	●	●	●	●	●
Cassette	●	●	●	●	●	●	●	●	●
Ceiling & Floor			●	●	●	●	●	●	●
Console	●	●	●						

●--- available model

1.3 Nomenclature

A U D - 60 U X 6 R P H H 4

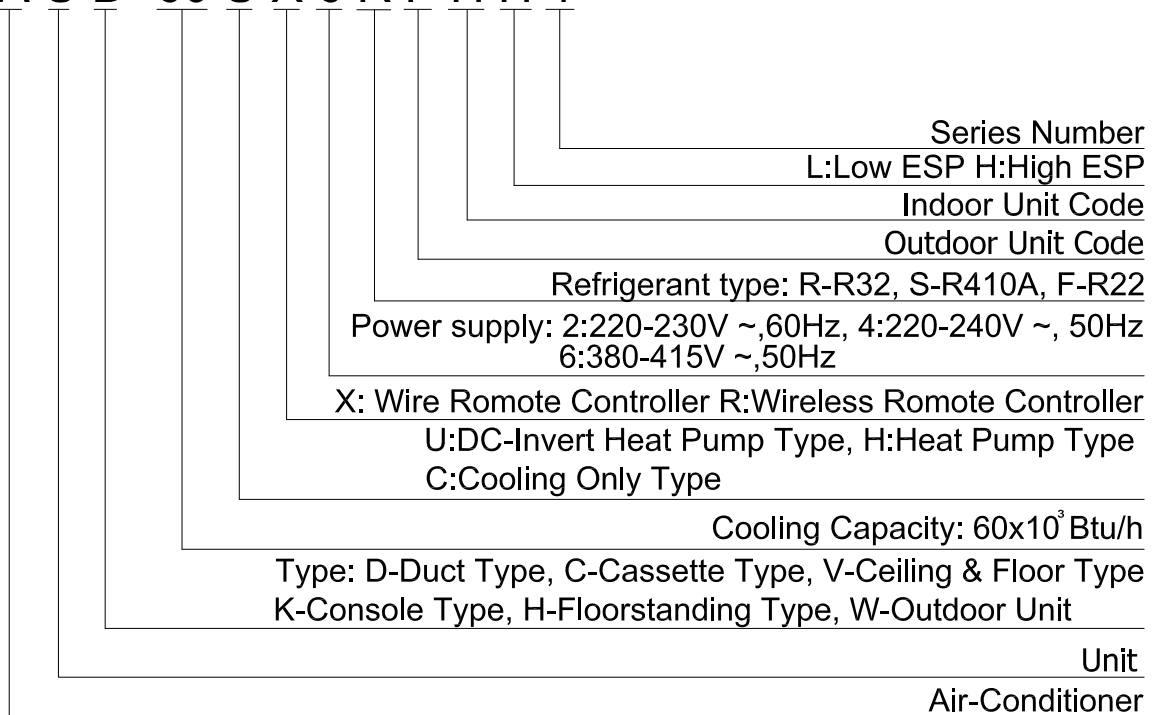

1. GENERAL

1.4 Unit installation

1:1 system is the only compatible combination.

(Only one indoor unit can be connected with 1 outdoor unit.)

1.5 Working range

Power Supply

Working Voltage	176V ~ 264V(9K~36K), 342V ~ 438V(42K~60K)
Voltage Imbalance	Within a 3% deviation from each voltage at the main terminal of outdoor unit
Starting Voltage	Higher than 85% of the Rated Voltage

Operating temperature range

This air conditioner is designed for the following outdoor operating temperatures.

Type	Mode	Outdoor operating temperature (°C)	
		maximum	minimum
DC-Inverter Split Air Conditioner (Heat pump type)	Cooling Operation	48	-15
	Heating Operation	24	-15

Storage condition:











Temperature: -25~60°C

Humidity: 30%~80%





1. GENERAL

1.6 Product appearance

Duct type

Model (Btu/h)	Indoor Unit	Outdoor Unit
9K		
12K		
18K		
24K		
30K		
36K		





1. GENERAL

Model (Btu/h)	Indoor Unit	Outdoor Unit
42K		
48K/60K		







Cassette type

Model (× 1000 Btu/h)	Indoor Unit	Outdoor Unit
9K		
12K/18K		
24K/30K		
36K		





1. GENERAL

Model (×1000 Btu/h)	Indoor Unit	Outdoor Unit
42K		
48K/60K		





Ceiling & Floor type

Model (×1000 Btu/h)	Indoor Unit	Outdoor Unit
18K		
24K		
30K		
36K		

1. GENERAL

Model (×1000 Btu/h)	Indoor Unit	Outdoor Unit
42K		
48K/60K		

Console type

Model (Btu/h)	Indoor Unit	Outdoor Unit
9K		
12K/18K		

1. GENERAL

Display panel

Duct Type

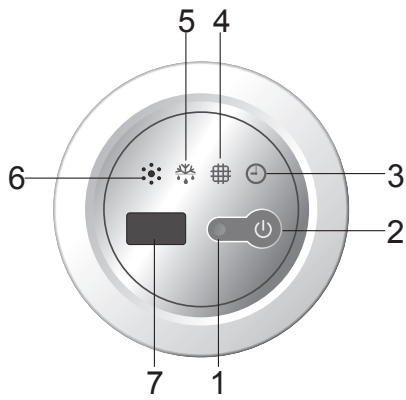

Cassette Type

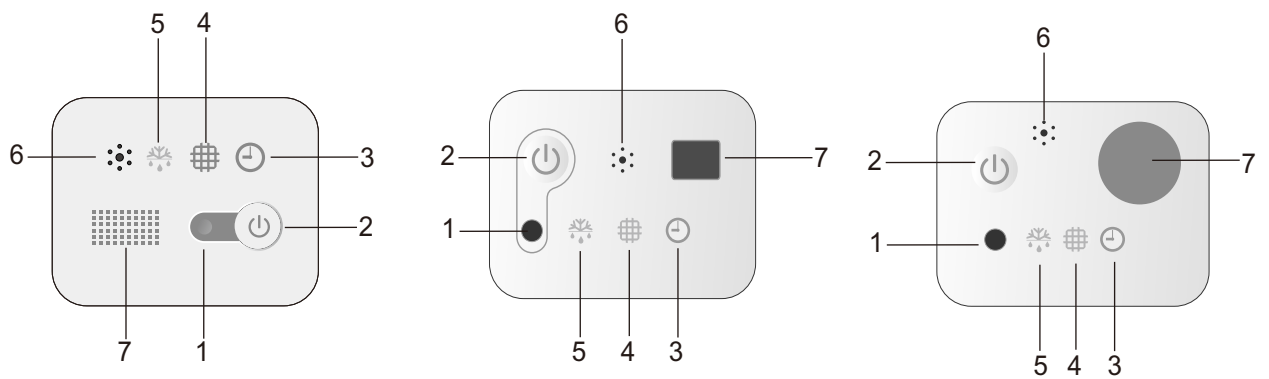

Ceiling & Floor type

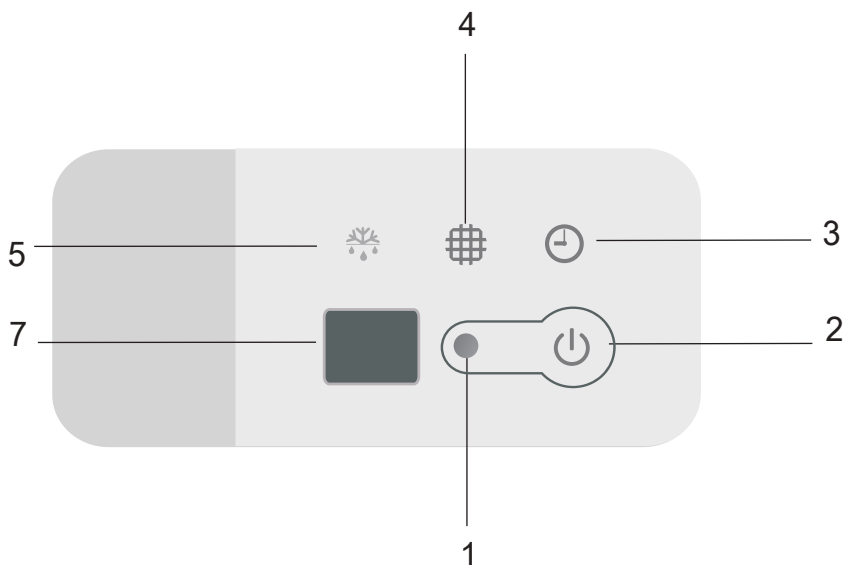

1. GENERAL

Description

- 1** Run indicator (Red)
It lights on during operation. It lights off during SLEEP mode.
- 2** Emergency switch
The filter clean indicator is reset when the switch is pressed. The unit will be started or stopped when the switch is pressed. The unit will be operated in forced cooling mode if press the switch continuously for more than 5s, the unit will operate in cooling mode.
- 3** Timer indicator (Green)
It lights on when timer is in use. It lights off when timer finishes.
- 4** Filter clean (Yellow)
It lights on when the filter should be cleaned.
- 5** Defrost indicator (Green)
It lights on during defrosting It lights off when defrosting is finished.
- 6** Buzzer
It beeps when the signal from remote controller is received.
- 7** Infrared receiver
Receives signal from the remote controller.

 • *The figures in this manual are based on the external view of a standard model. Consequently, the shape may differ from that of the air conditioner you have selected.*

1. GENERAL

Console type



Temperature indicator

Display set temperature.

It shows FC after setting hours of usage as reminder to clean the filter. (optional)

After filter cleaning press the filter reset button located on the indoor unit behind the front panel in order to reset the display.

It displays set humidity in humidity mode. (optional)



Running indicator

It lights up when the AC is running.



Timer indicator

It lights up during set time.



Sleep indicator

It lights up in sleep mode and will off after 10 seconds.

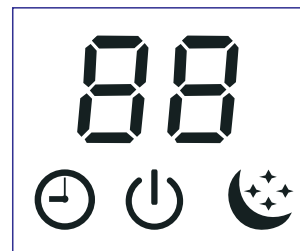

2. SPECIFICATIONS

2. Specifications

2.1 Duct type

Model				ADT-09UX4RRBL4	ADT-12UX4RSBL4	ADT-18UX4RSCL4	AUD-24UX4RFCL4	AUD-30UX4RFDH4	AUD-36UX4RADH4	AUD-42UX6RTHH4	AUD-48UX6RPHH4	AUD-60UX6RPHH4
Indoor model				ADT-09UX4RBL4	ADT-12UX4RBL4	ADT-18UX4RCL4	AUD-24UX4RCL4	AUD-30UX4RDH4	AUD-36UX4RDH4	AUD-42UX4RHH4	AUD-48UX4RHH4	AUD-60UX4RHH4
Outdoor model				AUW-09U4RR4	AUW-12U4RS4	AUW-18U4RS4	AUW-24U4RF4	AUW-30U4RF4	AUW-36U4RA4	AUW-42U6RT4	AUW-48U6RP4	AUW-60U6RP4
Electric parameter	Power supply	Indoor	V-ph-Hz	220-240/1/50	220-240/1/50	220-240/1/50	220-240/1/50	220-240/1/50	220-240/1/50	220-240/1/50	220-240/1/50	220-240/1/50
	Power supply	Outdoor	V-ph-Hz	220-240/1/50	220-240/1/50	220-240/1/50	220-240/1/50	220-240/1/50	220-240/1/50	380-415/3/50	380-415/3/50	380-415/3/50
	Input consumption	Max.	W	1490	1800	2000	4100	4100	5100	6400	7200	7800
	Input current	Max.	A	6.5	8.1	10.7	18.1	18.0	22.5	11.6	12.6	13.1
Seasonal efficiency	Cooling	Pdesignnc	W	2900	3520	5300	7200	8800	10500	12500	14400	17500
		SEER	W/W	6.27	6.30	6.40	6.43	6.20	6.13	—	—	—
		ηs,c	%	-	-	-	-	-	-	248	237	233
		Energy Efficiency Class	—	A++	A++	A++	A++	A++	A++	—	—	—
	Annual energy consumption	kWh/a	168	197	293	395	499	613	761	849	943	
	Heating (Average Season)	Pdesignnh	W	2400	3520	4400	6000	6500	8600	9500	12400	11000
		SCOP	W/W	4.23	4.01	4.0	4.18	4.00	4.00	—	—	—
		ηs,c	%	-	-	-	-	-	-	145	146	141
		Energy Efficiency Class	—	A+	A+	A+	A+	A+	A+	—	—	—
	Annual energy consumption	kWh/a	879	1214	1584	2007	2313	3010	3674	4694	4205	
	Tbiv	°C	-7	-7	-7	-7	-7	-7	-7	-7	-7	-7
	Tol	°C	-10	-10	-10	-10	-10	-10	-10	-10	-10	-10
Cooling	Capacity	Rated	Btu/h	9895	12010	18084	24566	30025	35836	42650	49133	59710
		Rated	W	2900	3520	5300	7200	8800	10500	12500	14400	17500
		Min - Max	W	1750~3400	1720~3850	2600~5600	2450~7850	4000~9500	3500~11000	3300~13200	3200~16000	3300~18500
	Input	Rated	W	828	1005	1610	2230	2670	3750	4220	4780	6600
	Current	Rated	A	3.6	4.5	7.4	10.4	11.6	16.5	7.4	8.7	12.5
	EER	Rated	W/W	3.50	3.50	3.29	3.23	3.30	2.8	2.96	3.01	2.65
Heating	Capacity	Rated	Btu/h	10577	12965	19790	26955	30708	39249	45734	59044	63140
		Rated	W	3100	3800	5800	7900	9000	11500	13400	17300	18500
		Min - Max	W	1750-3740	1770~4220	3000~6100	2200~8700	3500~9400	3320~12000	3000~14600	3400~18500	3000~19500
	Input	Rated	W	780	1000	1540	2130	2400	3380	4070	4670	6100
	Current	Rated	A	3.6	4.5	6.8	10.0	10.5	14.9	7.3	8.4	11.6
	COP	Rated	W/W	3.97	3.80	3.77	3.71	3.75	3.4	3.29	3.70	3.03
Indoor fan motor	Model		—	SIC-68CVL-F140-1	SIC-68CVL-F140-1	SIC-68CVL-F160-2	SIC-68CVL-F160-2	SIC-101CW-F1210	SIC-101CW-F1210	SIC-101CW-F1250-4	SIC-101CW-F1250	SIC-101CW-F1250
	Qty		—	1	1	1	1	1	1	1	1	1
	Output		W	40	40	60	60	210	210	250	250	250

2. SPECIFICATIONS

Model			ADT-09UX4RRBL4	ADT-12UX4RSBL4	ADT-18UX4RSCL4	AUD-24UX4RFCL4	AUD-30UX4RFDH4	AUD-36UX4RADH4	AUD-42UX6RTHH4	AUD-48UX6RPHH4	AUD-60UX6RPHH4	
Indoor model			ADT-09UX4RBL4	ADT-12UX4RBL4	ADT-18UX4RCL4	AUD-24UX4RCL4	AUD-30UX4RDH4	AUD-36UX4RDH4	AUD-42UX4RHH4	AUD-48UX4RHH4	AUD-60UX4RHH4	
Outdoor model			AUW-09U4RR4	AUW-12U4RS4	AUW-18U4RS4	AUW-24U4RF4	AUW-30U4RF4	AUW-36U4RA4	AUW-42U6RT4	AUW-48U6RP4	AUW-60U6RP4	
	Capacitor	uF	/	/	/	/	/	/	/	/	/	
	Speed(Hi/Med/Lo)	r/min	690/590/510	790/690/590	860/760/660	950/800/670	900/800/640	1050/980/900	910/810/710	1100/1000/900	1100/1000/900	
Indoor coil	Number of rows	—	3	3	3	3	3	3	3	3	3	
	Tube pitch(a)xrow pitch(b)	mm	21x13.6	21x13.6	21x13.6	21x13.6	21x13.6	21x13.6	21x18.19	21x18.19	21x18.19	
	Fin spacing	mm	1.6	1.6	1.6	1.6	1.6	1.6	1.4	1.4	1.4	
	Fin type	—	Hydrophilic aluminium	Hydrophilic aluminium	Hydrophilic aluminium	Hydrophilic aluminium	Hydrophilic aluminium	Hydrophilic aluminium	Hydrophilic aluminium	Hydrophilic aluminium	Hydrophilic aluminium	Hydrophilic aluminium
	Tube outside dia.and type	mm	Φ7, innergroove tube	Φ7, innergroove tube	Φ7, innergroove tube	Φ7, innergroove tube	Φ7, innergroove tube	Φ7, innergroove tube	Φ7, innergroove tube	Φ7, innergroove tube	Φ7, innergroove tube	Φ7, innergroove tube
	Coil length x height x width	mm	732×210×40.8	732×210×40.8	1002×210×40.8	1002×210×40.8	960×336×40.8	960×336×40.8	1100×378×54.6	1100×378×54.6	1100×378×54.6	1100×378×54.6
	Number of circuits	—	3	3	3	6	6	6	9	9	9	
Indoor unit	Dimension	WxHxD	mm	910×190×447	910×190×447	1180×190×447	1180×190×447	1140x268x720	1140x268x720	1300x350x800	1300x350x800	1300x350x800
	Packing	WxHxD	mm	1080×285×565	1080×285×565	1350×285×565	1350×285×565	1330×360×870	1330×360×870	1550×410×940	1550×410×940	1550×410×940
	Weight	Net/Gross	kg	18.0/21.5	18/21.5	22.5/26	22.5/26	37.5/44.5	37.5/44.5	51/60	51/60	51/60
	Air Volume	Hi/Med/Lo	m ³ /h	520/420/350	600/484/400	900/770/650	1000/700/490	1450/1120/900	1800/1600/1400	1750/1500/1300	2400/2200/1900	2400/2200/1900
		Hi/Med/Lo	CFM	309/250/208	338/285/235	536/458/327	588/411/288	853/659/529	853/735/618	1029/882/765	1412/1294/1118	1412/1294/1118
	Sound Level (SPL)	Hi/Med/Lo	dB(A)	32/29/26	36/33/30	41/37/33	39/35/32	42/39/35	50/47/43	42/39/36	48/45/42	49/46/43
	Sound Level (PWL)	Hi	dB(A)	47	50	57	58	59	64	67	73	73
	External Static Pressure	Rated	Pa	0	0	0	0	47	37	50	50	50
		Range	Pa	0~50	0~50	0~50	0~40	0~120	0~120	0~120	0~120	0~120
	Controller	Type	—	Wired	Wired	Wired	Wired	Wired	Wired	Wired	Wired	Wired
		Model	—	YXE-A02U(E) or others	YXE-A02U(E) or others	YXE-A02U(E) or others	YXE-A02U(E) or others	YXE-C01U(E)/YXE-A02U(E)	YXE-A02U(E) or others	YXE-A02U(E) or others	YXE-A02U(E) or others	YXE-A02U(E) or others
	Drainage water pipe diameter	mm	ODΦ32	ODΦ32	ODΦ32	ODΦ32	ODΦ32	ODΦ32	ODΦ32	ODΦ32	ODΦ32	ODΦ32
	Drain pump	—	Optional	Optional	Optional	Optional	Optional	Optional	Optional	Optional	Optional	Optional
	Air filter	—	Optional	Optional	Optional	Optional	Optional	Optional	Optional	Optional	Optional	Optional
	Throttle type	—	—	—	—	—	—	—	—	—	—	—
	Booster heater	kW	—	—	—	—	—	—	—	—	—	—
	Qty'per 20' /40' /40'HQ	—	—	160/352/396	160/352/396	128/264/297	128/264/297	60/126/147	35/75/90	35/75/90	35/75/90	35/75/90
Desian pressure	H/L	MPa	4.3/1.6	4.3/1.6	4.3/1.6	4.3/1.6	4.3/1.6	4.3/1.6	4.3/1.6	4.3/1.6	4.3/1.6	
Room temperature	Setting temperature range	Cooling	°C	16 - 30	16 - 30	16 - 30	16 - 30	16 - 30	16 - 30	16 - 30	16 - 30	16 - 30
		Heating	°C	16 - 30	16 - 30	16 - 30	16 - 30	16 - 30	16 - 30	16 - 30	16 - 30	16 - 30
Compressor	Model	—	KSK103D59UFZ	KSN108D43UFZ A	KTN150D42UFZ	KTM240D57UMT	KTM240D57UMT	KTF310D43UMT	KTF310D43UMT	KTF400D64UMT	KTQ420D1UMU	
	Type	—	ROTARY	ROTARY	ROTARY	ROTARY	ROTARY	ROTARY	ROTARY	ROTARY	ROTARY	
	Brand	—	GMCC	GMCC	GMCC	GMCC	GMCC	GMCC	GMCC	GMCC	GMCC	
	Capacity	Btu/h	11055	11635	15968	26323	26323	34163	34154	34470	46755.36	

2. SPECIFICATIONS

Model			ADT-09UX4RRBL4	ADT-12UX4RSBL4	ADT-18UX4RSCL4	AUD-24UX4RFCL4	AUD-30UX4RFDH4	AUD-36UX4RADH4	AUD-42UX6RTHH4	AUD-48UX6RPHH4	AUD-60UX6RPHH4	
Indoor model			ADT-09UX4RBL4	ADT-12UX4RBL4	ADT-18UX4RCL4	AUD-24UX4RCL4	AUD-30UX4RDH4	AUD-36UX4RDH4	AUD-42UX4RHH4	AUD-48UX4RHH4	AUD-60UX4RHH4	
Outdoor model			AUW-09U4RR4	AUW-12U4RS4	AUW-18U4RS4	AUW-24U4RF4	AUW-30U4RF4	AUW-36U4RA4	AUW-42U6RT4	AUW-48U6RP4	AUW-60U6RP4	
	Input	W	835	855.00	1185	2085	2085	2765	2765	3155	3700	
	Rated current(RLA)	A	5.65	5.70	7.70	9.45	9.45	5.4	5.38	13.2	7.02	
	Refrigerant oil	model	—	ESTER OIL VG74	ESTER OIL VG74	ESTEL OIL VG74	ESTEL OIL VG74	ESTEL OIL VG74	POE VG74	POE VG74	α68HES-H or equivalent	FV50S or PVE
Amount		ml	320	310	450	670	670	1000	1000	1650	1400	
Outdoor fan motor	Model	—	SIC-52FV-F130-3	SIC-52FV-F130-3	SIC-52FV-F130-3	SIC-61FW-F161-1	SIC-61FW-F161-1	SIC-71FW-F8121-1	SIC-81FW-F1138-1	YDK65-6-9061 & YDK65-6-9024	YDK65-6-9061 & YDK65-6-9024	
	Qty	—	1	1	1	1	1	1	1	2	2	
	Input	W	30	30	30	61	61	121	138	121	121	
	Capacitor	μF	—	—	—	—	—	—	—	—	—	—
	Speed	r/min	820	880	840	880	880	830	810	810	810	
Outdoor coil	Number of rows	—	1	2	3	2	2	2	2	2	2	
	Tube pitch(a)x row pitch(b)	mm	21x21.65	21x18.19	21x21.65	21x21.65	21x21.65	21x21.65	21x21.65	21x21.65	21x21.65	
	Fin spacing	mm	1.4	1.4	1.4	1.4	1.4	1.3	1.6	1.4	1.4	
	Fin type	—	Hydrophilic aluminium	Hydrophilic aluminium	Hydrophilic aluminium	Hydrophilic aluminium	Hydrophilic aluminium	Hydrophilic aluminium	Hydrophilic aluminium	Hydrophilic aluminium	Hydrophilic aluminium	
	Tube outside dia.and type	mm	Φ7.94,innergroove tube	Φ7,innergroove tube	Φ7,innergroove tube	Φ7.94, innergroove tube	Φ7.94, innergroove tube	Φ7.94, innergroove tube	Φ7.94, innergroove tube	Φ7.94, innergroove tube	Φ7.94, innergroove tube	
	Coil length xheight xwidth	mm	790x504x21.65	840x546x36.38	840x546x43.3	900x630x43.3	900x630x43.3	970x798x43.3	970x1008x43.5	970x1344x43	970x1344x43	
Number of circuits	—	2	2	3	6	6	5	6	12	12		
Outdoor unit	Dimension	WxHxD	mm	730×540×260	810×580×280	810×580×280	860×670×310	860×670×310	950×840×340	950×1050×340	950x1386x340	950x1386x340
	Packing	WxHxD	mm	860×590×400	940×420×640	940×640×420	990×730×450	990×730×450	1110×920×460	1110×1200×460	1110x1530x460	1110x1530x460
	Weight	Net/Gross	kg	28.0/31.0	34/38.5	36.0/40.0	49/53	49/53	70/75	85/95	101.5/114.5	117/129
	Air Volume	Hi	m ³ /h	1850	2300	2300	3150	3150	3800	5800	6300	6300
	Sound Level (SPL)	Hi	dB(A)	48	50	51	56	51	57	61	59	63
	Sound Level (PWL)	Hi	dB(A)	62	62	64	68	67	70	74	73	77
	Refrigerant	Type	—	R-32	R32	R32	R32	R32	R32	R32	R32	R32
		Amount	kg	0.75	0.85	0.97	1.40	1.45	2	2.50	3.00	3.40
		TCO2Eq	—	0.506	0.574	0.655	0.945	0.979	1.35	1.688	2.025	2.295
		GWP	—	675	675	675	675	675	675	675	675	675
	Throttle type	—	EEV	EEV	EEV	EEV	EEV	EEV	EEV	EEV	EEV	EEV
	Qty/per 20' /40' /40'HQ	—	136/284/284	102/204/272	102/204/272	90/186/186	90/186/186	52/106/106	26/53/106	26/53/53	26/53/53	
Design pressure	H/L	MPa	4.3/1.6	4.3/1.6	4.3/1.6	4.3/1.6	4.3/1.6	4.3/1.6	4.3/1.6	4.3/1.6	4.3/1.6	
Refrigerant piping	Liquid/ Gas	Mm (inch)	Φ6.35/Φ9.52 (1/4'/3/8')	Φ6.35/Φ9.52 (1/4'/3/8')	Φ6.35/Φ12.7 (1/4'/1/2')	Φ9.52/15.88 (3/8'/5/8')	Φ9.52/Φ15.88 (3/8'/5/8')	Φ9.52/19.05 (3/8'/3/4')	Φ9.52/Φ19.05 (3/8'/3/4')	Φ9.52/19.05 (3/8'/3/4')	Φ9.52/19.05 (3/8'/3/4')	
	Pipe length	Max.	m	25	25	30	30	50	50	50	50	
	Height difference	Max. (OD lower)	m	10	15	15	15	30	30	30	30	30
Max. (OD higher)		m	10	15	15	15	30	30	30	30	30	

2. SPECIFICATIONS

Model			ADT-09UX4RRBL4	ADT-12UX4RSBL4	ADT-18UX4RSCL4	AUD-24UX4RFCL4	AUD-30UX4RFDH4	AUD-36UX4RADH4	AUD-42UX6RTHH4	AUD-48UX6RPHH4	AUD-60UX6RPHH4
Indoor model			ADT-09UX4RBL4	ADT-12UX4RBL4	ADT-18UX4RCL4	AUD-24UX4RCL4	AUD-30UX4RDH4	AUD-36UX4RDH4	AUD-42UX4RHH4	AUD-48UX4RHH4	AUD-60UX4RHH4
Outdoor model			AUW-09U4RR4	AUW-12U4RS4	AUW-18U4RS4	AUW-24U4RF4	AUW-30U4RF4	AUW-36U4RA4	AUW-42U6RT4	AUW-48U6RP4	AUW-60U6RP4
	ADD Refrigerant AMOUNT	g/m	12	12	12	28	28	28	28	28	28
	PIPE LENGTH FOR ADDITIONAL Refrigerant	m	5	5	5	5	5	5	5	5	5
Operating Range (Outdoor)	Cooling	°C	-15~48	-15- 48	-15~48	-15~48	-15~48	-15~48	-15~48	-15~48	-15~48
	Heating	°C	-15~24	-15 - 24	-15~24	-15~24	-15~24	-15~24	-15~24	-15~24	-15~24

NOTE:

1. Test conditions:

Cooling : Indoor: DB27°C/ WB19°C Outdoor: DB35°C/ WB24°C

Heating: Indoor: DB20°C/ WB15°C Outdoor: DB7°C/ WB 6°C

2. The Sound Pressure Level is based on the following conditions:

Outdoor unit:

Measure the noise value of 3 points, the points are 1 meter in front of the three sides of the unit surface

(front/left/right) and height = 1/2(unit height + 1) meter from floor level, and calculate the weighted average of the noise.

Indoor unit:

Ducted:

Measure the noise value of the point 1.4m below the unit and 1.0m high from the ground.

3. The above data was measured in an anechoic chamber. Please take into consideration reflected sound of your specific application environment.

4. All specifications are subjected to change by the manufacturer without prior notice.

2. SPECIFICATIONS

2.2 Cassette type

Model				ACT-09UR4RRCA4	ACT-12UR4RSCA4	ACT-18UR4RSCA4	AUC-24UR4RFBG4	AUC-30UR4RFBG4	AUC-36UR4RAGB4	AUC-42UR6RTHB4	AUC-48UR6RPHB4	AUC-60UR6RPHB4	
Indoor model				ACT-09UR4RCA4	ACT-12UR4RCA4	ACT-18UR4RCA4	AUC-24UR4RGB4	AUC-30UR4RGB4	AUC-36UR4RGB4	AUC-42UR4RHB4	AUC-48UR4RHB4	AUC-60UR4RHB4	
Outdoor model				AUW-09U4RR4	AUW-12U4RS4	AUW-18U4RS4	AUW-24U4RF4	AUW-30U4RF4	AUW-36U4RA4	AUW-42U6RT4	AUW-48U6RP4	AUW-60U6RP4	
Panel				PE-EA-B29	PE-EA-B29	PE-EA-B29	PE-DA-B29	PE-DA-B29	PE-DA-B29	PE-DA-B29	PE-DA-B29	PE-DA-B29	
Electric parameter	Power supply	Indoor	V-ph-Hz	220-240/1/50	220-240/1/50	220-240/1/50	220-240/1/50	220-240/1/50	220-240/1/50	220-240/1/50	220-240/1/50	220-240/1/50	
	Power supply	Outdoor	V-ph-Hz	220-240/1/50	220-240/1/50	220-240/1/50	220-240/1/50	220-240/1/50	220-240/1/50	380-415/3/50	380-415/3/50	380-415/3/50	
	Input consumption	Max.	W	1550	1800	2120	4100	4100	5100	6400	7100	7800	
	Input current	Max.	A	6.7	8.1	10.3	18.1	18.0	22.5	11.6	12.1	13.1	
Seasonal efficiency	Cooling	Pdesignc	W	2800	3750	5200	7300	8800	10500	12500	14400	17200	
		SEER	W/W	6.10	6.90	6.60	6.59	6.10	6.15	—	—	—	
		ηs,c	%	—	—	—	—	—	—	239	227	219	
		Energy Efficiency Class	—	A++	A++	A++	A++	A++	A++	—	—	—	
		Annual energy consumption	kWh/a	170	190	285	388	511	604	757	894	883	
	Heating (Average Season)	Pdesignh	W	2300	3700	4400	6000	7200	8600	9500	13500	13500	
		SCOP	W/W	4.3	4.4	4.4	4.41	4.20	4	—	—	—	
		ηs,c	%	—	—	—	—	—	—	156	154	162	
		Energy Efficiency Class	—	A+	A+	A+	A+	A+	A+	—	—	—	
		Annual energy consumption	kWh/a	804	1200	1488	1907	2423	3010	3675	5086	4037	
		Tbiv	°C	-7	-7	-7	-7	-7	-7	-7	-7	-7	-7
	Tol	°C	-10	-10	-10	-10	-10	-10	-10	-10	-10	-10	
	Cooling	Capacity	Rated	Btu/h	9690	12795	17743	24908	30025	35829	42650	49133	58686
			Rated	W	2840	3750	5200	7300	8800	10500	12500	14400	17200
Min - Max			W	1330-3520	1720-4150	1630-5530	2400-7850	4000-9200	3530-12000	3300-13200	3400-16200	3300-18000	
Input		Rated	W	810	1000	1550	2100	2710	3620	4240	4770	6600	
Current		Rated	A	3.7	4.5	7.1	9.8	11.8	15.9	7.4	8.7	12.5	
EER		Rated	W/W	3.49	3.75	3.35	3.48	3.25	2.9	2.95	3.02	2.61	
Heating	Capacity	Rated	Btu/h	10680	13648	20131	28320	30708	38567	46062	58004	68240	
		Rated	W	3130	4000	5900	8300	9000	11300	13500	17000	20000	
		Min - Max	W	1110-3930	1770-4650	1590-6270	2100-8800	3500-9500	3320-13000	3000-14600	3700-18000	3000-21000	
	Input	Rated	W	740	1000	1590	2170	2250	3230	3700	4640	6650	
	Current	Rated	A	3.5	4.5	7.4	10.2	9.8	14.2	6.5	8.4	12.6	
	COP	Rated	W/W	4.22	4.00	3.71	3.82	3.85	3.50	3.65	3.66	3.01	
Indoor fan motor	Model		—	SIC-62FW-D857-15	SIC-62FW-D857-15	SIC-62FW-D857-15	EHDS50AQH	EHDS50AQH	EHDS50AQH	SIC-72FW-D812-4-28	SIC-72FW-D812-4-2B	SIC-72FW-D812-4-2B	
	Qty		—	1	1	1	1	1	1	1	1	1	

2. SPECIFICATIONS

Model			ACT-09UR4RCCA4	ACT-12UR4RSCA4	ACT-18UR4RSCA4	AUC-24UR4RFB4	AUC-30UR4RFB4	AUC-36UR4RAGB4	AUC-42UR6RTHB4	AUC-48UR6RPHB4	AUC-60UR6RPHB4	
Indoor model			ACT-09UR4RCA4	ACT-12UR4RCA4	ACT-18UR4RCA4	AUC-24UR4RGB4	AUC-30UR4RGB4	AUC-36UR4RGB4	AUC-42UR4RHB4	AUC-48UR4RHB4	AUC-60UR4RHB4	
Outdoor model			AUW-09U4RR4	AUW-12U4RS4	AUW-18U4RS4	AUW-24U4RF4	AUW-30U4RF4	AUW-36U4RA4	AUW-42U6RT4	AUW-48U6RP4	AUW-60U6RP4	
Panel			PE-EA-B29	PE-EA-B29	PE-EA-B29	PE-DA-B29	PE-DA-B29	PE-DA-B29	PE-DA-B29	PE-DA-B29	PE-DA-B29	
	Output	W	57	57	57	80	80	80	124	124	124	
	Capacitor	uF	—	—	—	—	—	—	—	—	—	
	Speed(Hi/Med/Lo)	r/min	600/500/400	690/600/500	810/670/620	460/400/300	550/480/390	600/480/390	630/600/570	700/540/460	740/540/460	
Indoor coil	Number of rows	—	2	3	3	2	3	3	3	3	3	
	Tube pitch(a)xrow pitch(b)	mm	13.89×9.4	13.89×9.4	13.89×9.4	21×13.6	21×13.6	21×13.6	21×13.6	21×13.6	21×13.6	
	Fin spacing	mm	1.3	1.3	1.3	1.5	1.5	1.5	1.5	1.5	1.5	
	Fin type	—	Hydrophilic aluminium	Hydrophilic aluminium	Hydrophilic aluminium	Hydrophilic aluminium	Hydrophilic aluminium	Hydrophilic aluminium	Hydrophilic aluminium	Hydrophilic aluminium	Hydrophilic aluminium	
	Tube outside dia.and type	mm	Φ5,innergroove tube	Φ5,innergroove tube	Φ5,innergroove tube	Φ7,innergroove tube	Φ7, innergroove tube	Φ7, innergroove tube	Φ7, innergroove tube	Φ7, innergroove tube	Φ7, innergroove tube	
	Coil length x height x width	mm	1213×166.68×18.8	1213×166.68×28.2	1213×166.68×28.2	1870×189×27.2	1940×189×40.8	1940×189×40.8	1940×252×40.8	1940×252×40.8	1940×252×40.8	
	Number of circuits	—	6	6	6	6	5	6	6	6	6	
Indoor unit	Dimension	WxHxD	mm	570×570×215	570×570×215	570×570×215	840×248×840	840×248×840	840×248×840	840×298×840	840×298×840	840×298×840
	Packing	WxHxD	mm	730×668×292	730×668×292	730×668×292	996×370×956	996×370×956	996×370×956	996×420×956	996×420×956	996×420×956
	Weight	Net/Gross	kg	14.5/17.5	15.5/18.5	15.5/18.5	25/34	27/36	27/36	32/41	32/41	32/41
	Air Volume	Hi/Med/Lo	m ³ /h	520/410/320	580/500/400	700/600/510	1180/980/720	1400/1120/900	1600/1300/1000	1850/1700/1550	2100/1700/1400	2100/1700/1400
		Hi/Med/Lo	CFM	309/244/190	341/294/235	416/357/303	694/576/423	824/659/529	941/765/588	1088/1000/912	1235/1000/824	1235/1000/824
	Sound Level (SPL)	Hi/Med/Lo	dB(A)	39/35/31	41/37/33	47/42/40	45/41/37	43/40/37	47/43/40	50/48/46	53/46/44	53/46/44
	Sound Level (PWL)	Hi	dB(A)	52	53	57	57	60	63	62	65	63
	External Static Pressure	Rated	Pa	—	—	—	—	—	—	—	—	—
		Range	Pa	—	—	—	—	—	—	—	—	—
	Controller	Type	—	Wireless	Wireless	Wireless	Wireless	Wireless	Wireless	Wireless	Wireless	Wireless
		Model	—	R2-01 or others	R2-01 or others	R2-01 or others	R2-01 or others	R2-01 or others	R2-01 or others	R2-01 or others	R2-01 or others	R2-01 or others
	Drainage water pipe diameter	mm	mm	ODΦ32	ODΦ32	ODΦ32	ODΦ32	ODΦ32	ODΦ32	ODΦ32	ODΦ32	ODΦ32
	Drain pump	—	Standard	Standard	Standard	Standard	Standard	Standard	Standard	Standard	Standard	Standard
	Air filter	—	Standard	Standard	Standard	Standard	Standard	Standard	Standard	Standard	Standard	Standard
	Throttle type	—	—	—	—	—	—	—	—	—	—	—
	Booster heater	kW	—	—	—	—	—	—	—	—	—	—
	Qty'per 20' /40' /40'HQ	—	—	140/298/330	140/298/330	140/298/330	60/124/140	60/124/140	60/124/140	50/114/128	50/114/128	50/114/128
Design	H/L	MPa	4.3/1.6	4.3/1.6	4.3/1.6	4.3/1.6	4.3/1.6	4.3/1.6	4.3/1.6	4.3/1.6	4.3/1.6	
Panel	Dimension	WxHxD	mm	620×620×37	620×620×37	620×620×37	950×45×950	950×45×950	950×45×950	950×45×950	950×45×950	
	Packing	WxHxD	mm	690×680×115	690×680×115	690×680×115	1025×120×1015	1025×120×1015	1025×120×1015	1025×120×1015	1025×120×1015	
	Weight	Net/Gross	kg	2.6/4.5	2.6/4.5	2.6/4.5	6.5/9.5	6.5/9.5	6.5/9.5	6.5/9.5	6.5/9.5	
Room temperature	Setting temperature range	Cooling	℃	16 - 30	16 - 30	16 - 30	16 - 30	16 - 30	16 - 30	16 - 30	16 - 30	
		Heating	℃	16 - 30	16 - 30	16 - 30	16 - 30	16 - 30	16 - 30	16 - 30	16 - 30	

2. SPECIFICATIONS

Model			ACT-09UR4RRCA4	ACT-12UR4RSCA4	ACT-18UR4RSCA4	AUC-24UR4RFB4	AUC-30UR4RFB4	AUC-36UR4RAGB4	AUC-42UR6RTHB4	AUC-48UR6RPHB4	AUC-60UR6RPHB4	
Indoor model			ACT-09UR4RCA4	ACT-12UR4RCA4	ACT-18UR4RCA4	AUC-24UR4RGB4	AUC-30UR4RGB4	AUC-36UR4RGB4	AUC-42UR4RHB4	AUC-48UR4RHB4	AUC-60UR4RHB4	
Outdoor model			AUW-09U4RR4	AUW-12U4RS4	AUW-18U4RS4	AUW-24U4RF4	AUW-30U4RF4	AUW-36U4RA4	AUW-42U6RT4	AUW-48U6RP4	AUW-60U6RP4	
Panel			PE-EA-B29	PE-EA-B29	PE-EA-B29	PE-DA-B29	PE-DA-B29	PE-DA-B29	PE-DA-B29	PE-DA-B29	PE-DA-B29	
Compressor	Model	—	KSK103D59UFZ	KSN108D43UFZ A	KTN150D42UFZ	KTM240D57UMT	KTM240D57UMT	KTF310D43UMT	KTF310D43UMT	KTF400D64UMT	KTQ420D1UMU	
	Type	—	ROTARY	ROTARY	ROTARY	ROTARY	ROTARY	ROTARY	ROTARY	ROTARY	ROTARY	
	Brand	—	GMCC	GMCC	GMCC	GMCC	GMCC	GMCC	GMCC	GMCC	GMCC	
	Capacity	Btu/h	11055	11635	15968	26323	26323	34163	34154	34470	46755.36	
	Input	W	835	855.00	1185	2085	2085	2765	2765	3155	3700	
	Rated current(RLA)	A	5.65	5.70	7.70	9.45	9.45	5.4	5.38	13.2	7.02	
	Refrigerant oil	model	—	ESTER OIL VG74	ESTER OIL VG74	ESTEL OIL VG74	ESTEL OIL VG74	ESTEL OIL VG74	POE VG74	POE VG74	α68HES-H or equivalent	FV50S or PVE
Amount		ml	320	310	450	670	670	1000	1000	1650	1400	
Outdoor fan motor	Model	—	SIC-52FV-F130-3	SIC-52FV-F130-3	SIC-52FV-F130-3	SIC-61FW-F161-1	SIC-61FW-F161-1	SIC-71FW-F8121-1	SIC-81FW-F1138-1	YDK65-6-9061 & YDK65-6-9024	YDK65-6-9061 & YDK65-6-9024	
	Qty	—	1	1	1	1	1	1	1	2	2	
	Input	W	30	30	30	61	61	121	138	121	121	
	Capacitor	μF	—	—	—	—	—	—	—	—	—	
	Speed	r/min	820.00	880	840	880	880	830	810	810	810	
Outdoor coil	Number of rows	—	1	2	2	2	2	2	2	2	2	
	Tube pitch(a)x row pitch(b)	mm	21x21.65	21x18.19	21x21.65	21x21.65	21x21.65	21x21.65	21x21.65	21x21.65	21x21.65	
	Fin spacing	mm	1.4	1.4	1.4	1.4	1.4	1.3	1.6	1.4	1.4	
	Fin type	—	Hydrophilic aluminium	Hydrophilic aluminium	Hydrophilic aluminium	Hydrophilic aluminium	Hydrophilic aluminium	Hydrophilic aluminium	Hydrophilic aluminium	Hydrophilic aluminium	Hydrophilic aluminium	
	Tube outside dia.and type	mm	Φ7.94, innergroove tube	Φ7, innergroove tube	Φ7, innergroove tube	Φ7.94, innergroove tube	Φ7.94, innergroove tube	Φ7.94, innergroove tube	Φ7.94, innergroove tube	Φ7.94, innergroove tube	Φ7.94, innergroove tube	
	Coil length xheight xwidth	mm	790x504x21.65	840x546x36.38	840x546x43.3	900x630x43.3	900x630x43.3	970x798x43.3	970x1008x43.5	970x1344x43	970x1344x43	
Number of circuits	—	2	2	3	6	6	5	6	12	12		
Outdoor unit	Dimension	WxHxD	mm	730×540×260	810×580×280	810×580×280	860×670×310	860×670×310	950×840×340	950×1050×340	950x1386x340	950x1386x340
	Packing	WxHxD	mm	860×590×400	940×420×640	940×640×420	990×730×450	990×730×450	1110×920×460	1110×1200×460	1110x1530x460	1110x1530x460
	Weight	Net/Gross	kg	28.0/31.0	34/38.5	36/40	49/53	49/53	70/75	85/95	101.5/114.5	117/129
	Air Volume	Hi	m ³ /h	1850	2300	2300	3150	3150	3800	5800	6300	6300
	Sound Level (SPL)	Hi	dB(A)	48	50	51	56	53	57	61	59	63
	Sound Level (PWL)	Hi	dB(A)	62	62	64	68	67	70	74	73	77
	Refrigerant	Type	—	R32	R32	R32	R32	R32	R32	R32	R32	R32
		Amount	kg	0.75	0.85	0.97	1.4	1.45	2.00	2.50	3.00	3.40
		TCO2Eq	—	0.506	0.574	0.655	0.945	0.979	1.35	1.688	2.025	2.666
		GWP	—	675	675	675	675	675	675	675	675	675
Throttle type	—	EEV	EEV	EEV	EEV	EEV	EEV	EEV	EEV	EEV	EEV	
Qty'per 20' /40' /40'HQ	—	136/284/284	102/204/272	102/204/272	90/186/186	90/186/186	52/106/106	26/53/106	26/53/53	26/53/53		

2. SPECIFICATIONS

Model				ACT-09UR4RRCA4	ACT-12UR4RSCA4	ACT-18UR4RSCA4	AUC-24UR4RFB4	AUC-30UR4RFB4	AUC-36UR4RAGB4	AUC-42UR6RTHB4	AUC-48UR6RPHB4	AUC-60UR6RPHB4	
Indoor model				ACT-09UR4RCA4	ACT-12UR4RCA4	ACT-18UR4RCA4	AUC-24UR4RGB4	AUC-30UR4RGB4	AUC-36UR4RGB4	AUC-42UR4RHB4	AUC-48UR4RHB4	AUC-60UR4RHB4	
Outdoor model				AUW-09U4RR4	AUW-12U4RS4	AUW-18U4RS4	AUW-24U4RF4	AUW-30U4RF4	AUW-36U4RA4	AUW-42U6RT4	AUW-48U6RP4	AUW-60U6RP4	
Panel				PE-EA-B29	PE-EA-B29	PE-EA-B29	PE-DA-B29	PE-DA-B29	PE-DA-B29	PE-DA-B29	PE-DA-B29	PE-DA-B29	
	Design pressure	H/L	MPa	4.3/1.6	4.3/1.6	4.3/1.6	4.3/1.6	4.3/1.6	4.3/1.6	4.3/1.6	4.3/1.6	4.3/1.6	
Refrigerant piping	Liquid/ Gas		Mm (inch)	Φ6.35/Φ9.52 (1/4'/3/8')	Φ6.35/Φ9.52 (1/4'/3/8')	Φ6.35/Φ12.7 (1/4'/1/2')	Φ9.52/15.88 (3/8'/5/8')	Φ9.52/Φ15.88 (3/8'/5/8')	Φ9.52/19.05 (3/8'/3/4')	Φ9.52/Φ19.05 (3/8'/3/4')	Φ9.52/19.05 (3/8'/3/4')	Φ9.52/19.05 (3/8'/3/4')	
	Pipe length	Max.	m	25	25	30	30	50	50	50	50	50	
	Height difference	Max. (OD lower)	m	10	15	15	15	15	30	30	30	30	30
		Max. (OD higher)	m	10	15	15	15	15	30	30	30	30	30
	ADD Refrigerant AMOUNT			g/m	12	12	12	28	28	28	28	28	28
PIPE LENGTH FOR ADDITIONAL Refrigerant			m	5	5	5	5	5	5	5	5	5	
Operating Range (Outdoor)	Cooling		°C	-15~48	-15- 48	-15~48	-15~48	-15~48	-15~48	-15~48	-15~48	-15~48	
	Heating		°C	-15~24	-15 - 24	-15~24	-15~24	-15~24	-15~24	-15~24	-15~24	-15~24	

NOTE:

1. Test conditions:

Cooling : Indoor: DB27°C/ WB19°C Outdoor: DB35°C/ WB24°C

Heating: Indoor: DB20°C/ WB15°C Outdoor: DB7°C/ WB 6°C

2. The Sound Pressure Level is based on the following conditions:

Outdoor unit:

Measure the noise value of 3 points, the points are 1 meter in front of the three sides of the unit surface

(front/left/right) and height =1/2(unit height +1) meter from floor level, and calculate the weighted average of the noise.

Indoor unit:

Cassette:

Measure the noise value of the point 1.4m below the unit and 1.0m high from the ground.

3. The above data was measured in an anechoic chamber. Please take into consideration reflected sound of your specific application environment.

4. All specifications are subjected to change by the manufacturer without prior notice.

2. SPECIFICATIONS

2.3 Ceiling & Floor type

Model				AVT-18UR4RSA4	AUV-24UR4RFA4	AUV-30UR4RFB4	AUV-36UR4RAB4	AUV-42UR6RTC4	AUV-48UR6RPC4	AUV-60UR6RPC4
Indoor model				AVT-18UR4RA4	AUV-24UR4RA4	AUV-30UR4RB4	AUV-36UR4RB4	AUV-42UR4RC4	AUV-48UR4RC4	AUV-60UR4RC4
Outdoor model				AUW-18U4RS4	AUW-24U4RF4	AUW-30U4RF4	AUW-36U4RA4	AUW-42U6RT4	AUW-48U6RP4	AUW-60U6RP4
Electric parameter	Power supply	Indoor	V-ph-Hz	220-240/1/50	220-240/1/50	220-240/1/50	220-240/1/50	220-240/1/50	220-240/1/50	220-240/1/50
	Power supply	Outdoor	V-ph-Hz	220-240/1/50	220-240/1/50	220-240/1/50	220-240/1/50	380-415/3/50	380-415/3/50	380-415/3/50
	Input consumption	Max.	W	2000	4100	4100	5100	6400	7000	8200
	Input current	Max.	A	8.7	18.1	18.0	22.5	11.6	12.0	13.5
Seasonal efficiency	Cooling	Pdesignc	W	5200	6900	8800	10000	12300	14300	17000
		SEER	W/W	6.3	6.11	6.1	6.1	—	—	—
		η s,c	%	—	—	—	—	225	219	203
		Energy Efficiency Class	—	A++	A++	A++	A++	—	—	—
		Annual energy consumption	kWh/a	301	387	509	583	803	940	876
	Heating (Average Season)	Pdesignh	W	4700	6000	6500	8600	9500	12200	11000
		SCOP	W/W	4.4	4.18	4.1	4	—	—	—
		η s,c	%	—	—	—	—	148	147	143
		Energy Efficiency Class	—	A+	A+	A+	A+	—	—	—
		Annual energy consumption	kWh/a	1507	2007	2192	3010	3868	5015	4509
	Tbiv	°C	-7	-7	-7	-7	-7	-7	-7	
	Toi	°C	-10	-10	-10	-10	-10	-10	-10	
Cooling	Capacity	Rated	Btu/h	18016	23543	30025	34130	41968	48792	58004
		Rated	W	5280	6900	8800	10000	12300	14300	17000
		Min - Max	W	1480-5500	2500-7900	3500-9000	3500-11000	3300-13200	3100~16100	3300~18000
	Input	Rated	W	1630	2150	2910	3570	4400	4710	6600
	Current	Rated	A	7.8	9.8	12.7	15.8	7.5	8.5	12.5
	EER	Rated	W/W	3.23	3.21	2.95	2.8	2.80	3.04	2.58
Heating	Capacity	Rated	Btu/h	19108	26614	30708	38567	46062	56980	61416
		Rated	W	5600	7800	9000	11300	13500	16700	18000
		Min - Max	W	1670-6360	2200-9200	3000-9200	3320-12000	3000-14600	3600~18000	3000~19000
	Input	Rated	W	1420	2350	2300	3420	4170	5580	6100
	Current	Rated	A	6.3	10.7	10.0	15.1	7.3	9	11.6
	COP	Rated	W/W	3.94	3.32	3.90	3.3	3.24	2.99	2.95
Indoor fan motor	Model		—	SIC-70CW-F1100-6	SIC-70CW-F1100-6	SIC-70CW-F1140-3	SIC-70CW-F1140-3	SIC-101CW-F1181-2	SIC-101CW-F1181-1	SIC-101CW-F1181-1
	Qty		—	1	1	1	1	1	1	1
	Output		W	100	100	140	140	181	181	181
	Capacitor		uF	—	—	—	—	—	—	—

2. SPECIFICATIONS

Model			AVT-18UR4RSA4	AUV-24UR4FA4	AUV-30UR4RFB4	AUV-36UR4RAB4	AUV-42UR6RTC4	AUV-48UR6RPC4	AUV-60UR6RPC4	
Indoor model			AVT-18UR4RA4	AUV-24UR4RA4	AUV-30UR4RB4	AUV-36UR4RB4	AUV-42UR4RC4	AUV-48UR4RC4	AUV-60UR4RC4	
Outdoor model			AUW-18U4RS4	AUW-24U4RF4	AUW-30U4RF4	AUW-36U4RA4	AUW-42U6RT4	AUW-48U6RP4	AUW-60U6RP4	
	Speed(Hi/Med/Lo)	r/min	820/720/650	1150/1030/910	1150/930/800	1220/1160/1080	1200/1100/1000	1250/1000/800	1250/1100/950	
Indoor coil	Number of rows	—	3	3	3	3	3	3	3	
	Tube pitch(a)xrow pitch(b)	mm	21x13.6	21x13.6	21x13.6	21x13.6	21x13.6	21x13.6	21x13.6	
	Fin spacing	mm	1.5	1.5	1.5	1.5	1.5	1.5	1.5	
	Fin type	—	Hydrophilic aluminium	Hydrophilic aluminium	Hydrophilic aluminium	Hydrophilic aluminium	Hydrophilic aluminium	Hydrophilic aluminium	Hydrophilic aluminium	
	Tube outside dia.and type	mm	Φ7,innergroove tube	Φ7,innergroove tube	Φ7, innergroove tube	Φ7, innergroove tube	Φ7, innergroove tube	Φ7, innergroove tube	Φ7, innergroove tube	
	Coil length x height x width	mm	660x336x40.8	660x336x40.8	930x336x40.8	930x336x40.8	1200x336x40.8	1200x336x40.8	1200x336x54.4	
	Number of circuits	—	3	6	7	7	7	7	7	
Indoor unit	Dimension	WxHxD	mm	990x230x680	990x230x680	1285x230x680	1285x230x680	1580x230x680	1580x230x680	1580x230x680
	Packing	WxHxD	mm	1100x350x820	1100x350x820	1400x350x820	1400x350x820	1690x350x820	1690x350x820	1690x350x820
	Weight	Net/Gross	kg	30/35	30/35	37/44	37/44	48/56	48/56	50/58
	Air Volume	Hi/Med/Lo	m ³ /h	800/690/600	1100/950/800	1450/1120/900	1700/1500/1300	2000/1800/1600	2000/1600/1200	2000/1700/1500
		Hi/Med/Lo	CFM	476/410/357	647/559/471	853/659/529	1000/882/765	1176/1059/941	1176/941/706	1176/941/706
	Sound Level (SPL)	Hi/Med/Lo	dB(A)	40/36/33	51/48/45	49/43/40	50/49/47	53/50/47	55/51/48	55/51/48
	Sound Level (PWL)	Hi	dB(A)	57	65	65	65	66	68	67
	External Static Pressure	Rated	Pa	—	—	—	—	—	—	—
		Range	Pa	—	—	—	—	—	—	—
	Controller	Type	—	Wireless	Wireless	Wireless	Wireless	Wireless	Wireless	Wireless
		Model	—	R2-01 or others	R2-01 or others	R2-01 or others	R2-01 or others	R2-01 or others	R2-01 or others	R2-01 or others
	Drainage water pipe diameter		mm	ODΦ25	ODΦ25	ODΦ25	ODΦ25	ODΦ25	ODΦ25	ODΦ25
	Drain pump		—	—	—	—	—	—	—	—
	Air filter		—	Standard	Standard	Standard	Standard	Standard	Standard	Standard
	Throttle type		—	—	—	—	—	—	—	—
Booster heater		kW	—	—	—	—	—	—	—	
Qty'per 20' /40' /40'HQ		—	90/186/186	90/186/186	66/132/153	66/132/153	42/84/98	42/84/98	42/84/98	
Design pressure	H/L	MPa	4.3/1.6	4.3/1.6	4.3/1.6	4.3/1.6	4.3/1.6	4.3/1.6	4.3/1.6	
Room temperature	Setting temperature range	Cooling	°C	16 - 30	16 - 30	16 - 30	16 - 30	16 - 30	16 - 30	
		Heating	°C	16 - 30	16 - 30	16 - 30	16 - 30	16 - 30	16 - 30	
Compressor	Model	—	KTN150D42UFZ	KTM240D57UMT	KTM240D57UMT	KTF310D43UMT	KTF310D43UMT	KTF400D64UMT	KTQ420D1UMU	
	Type	—	ROTARY	ROTARY	ROTARY	ROTARY	ROTARY	ROTARY	ROTARY	
	Brand	—	GMCC	GMCC	GMCC	GMCC	GMCC	GMCC	GMCC	
	Capacity	Btu/h	15968	26323	26327	34163	34154	34470	46755.36	
	Input	W	1185	2085	2085	2765	2765	3155	3700	
	Rated current(RLA)	A	7.70	8.90	9.45	5.40	5.38	13.20	7.02	
	Refrigerant oil	model	—	ESTEL OIL VG74	ESTEL OIL VG74	ESTEL OIL VG74	POE VG74	POE VG74	α 68HES-H or equivalent	FV50S or PVE
Amount		ml	450	670	670	1000	1000	1650	1400	

2. SPECIFICATIONS

Model			AVT-18UR4RSA4	AUV-24UR4RFA4	AUV-30UR4RFB4	AUV-36UR4RAB4	AUV-42UR6RTC4	AUV-48UR6RPC4	AUV-60UR6RPC4	
Indoor model			AVT-18UR4RA4	AUV-24UR4RA4	AUV-30UR4RB4	AUV-36UR4RB4	AUV-42UR4RC4	AUV-48UR4RC4	AUV-60UR4RC4	
Outdoor model			AUW-18U4RS4	AUW-24U4RF4	AUW-30U4RF4	AUW-36U4RA4	AUW-42U6RT4	AUW-48U6RP4	AUW-60U6RP4	
Outdoor fan motor	Model	—	SIC-52FV-F130-3	SIC-61FW-F161- 1	SIC-61FW-F161-1	SIC-71FW-F8121-1	SIC-81FW-F1138-1	YDK65-6-9061 & YDK65-6-9024	YDK65-6-9061 & YDK65-6-9024	
	Qty	—	1	1	1	1	1	2	2	
	Input	W	30	61	61	121	138	121	121	
	Capacitor	μF	—	—	—	—	—	—	—	
	Speed	r/min	840	880	880	830	810	810	810	
Outdoor coil	Number of rows	—	2	2	2	2	2	2	2	
	Tube pitch(a)x row pitch(b)	mm	21x21.65	21x21.65	21x21.65	21x21.65	21x21.65	21x21.65	21x21.65	
	Fin spacing	mm	1.4	1.4	1.4	1.3	1.6	1.4	1.4	
	Fin type	—	Hydrophilic aluminium	Hydrophilic aluminium	Hydrophilic aluminium	Hydrophilic aluminium	Hydrophilic aluminium	Hydrophilic aluminium	Hydrophilic aluminium	
	Tube outside dia.and type	mm	Φ7,innergroove tube	Φ7.94,innergroove tube	Φ7.94,innergroove tube	Φ7.94, innergroove tube	Φ7.94, innergroove tube	Φ7.94,innergroove tube	Φ7.94,innergroove tube	
	Coil length xheight xwidth	mm	840x546x43.3	900x630x43. 3	900x630x43.3	970x798x43.3	970x1008x43.5	970x1344x43	970x1344x43	
	Number of circuits	—	3	6	6	5	6	12	12	
Outdoor unit	Dimension	WxHxD	mm	810x580x280	860x670x310	860x670x310	950x840x340	950x1050x340	950x1386x340	950x1386x340
	Packing	WxHxD	mm	940x640x420	990x730x450	990x730x450	1110x920x460	1110x1200x460	1110x1530x460	1110x1530x460
	Weight	Net/Gross	kg	36.0/40.0	56/60	49/53	70/75	85/95	101.5/114.5	117/129
	Air Volume	Hi	m ³ /h	2300	3150	3150	3800	5800	6300	6300
	Sound Level (SPL)	Hi	dB(A)	51	56	51	57	61	59	63
	Sound Level (PWL)	Hi	dB(A)	64	68	67	70	74	73	77
	Refrigerant	Type	—	R32	R32	R32	R32	R32	R32	R32
		Amount	kg	0.97	1.4	1.45	2	2.50	3.00	3.95
		TCO2Eq	—	0.655	0.945	0.979	1.35	1.688	2.025	2.666
		GWP	—	675	675	675	675	675	675	675
	Throttle type	—	EEV	EEV	EEV	EEV	EEV	EEV	EEV	EEV
	Qty'per 20' /40' /40'HQ	—	102/204/272	90/186/186	90/186/186	52/106/106	26/53/106	26/53/53	26/53/53	26/53/53
Design pressure	H/L	MPa	4.3/1.6	4.3/1.6	4.3/1.6	4.3/1.6	4.3/1.6	4.3/1.6	4.3/1.6	
Refrigerant piping	Liquid/ Gas	mm(inch)	Φ6.35/Φ12.7 (1/4'/1/2')	Φ9.52/Φ15.88 (3/8'/5/8')	Φ9.52/Φ15.88 (3/8'/5/8')	Φ9.52/Φ19.05 (3/8'/3/4')	Φ9.52/Φ19.05 (3/8'/3/4')	Φ9.52/Φ19.05 (3/8'/3/4')	Φ9.52/Φ19.05 (3/8'/3/4')	
	Pipe length	Max.	m	30	30	50	50	50	50	
	Height difference	Max. (OD lower)	m	15	15	30	30	30	30	
		Max. (OD higher)	m	15	15	30	30	30	30	
	ADD Refrigerant AMOUNT	g/m	12	28	28	28	28	28	28	
PIPE LENGTH FOR ADDITIONAL Refrigerant	m	5	5	5	5	5	5	5		
Operating Range (Outdoor)	Cooling	°C	-15~48	-15~48	-15~48	-15~48	-15~48	-15~48	-15~48	
	Heating	°C	-15~24	-15~24	-15~24	-15~24	-15~24	-15~24	-15~24	

2. SPECIFICATIONS

NOTE:

1. Test conditions:

Cooling : Indoor: DB27°C/ WB19°C Outdoor: DB35°C/ WB24°C

Heating: Indoor: DB20°C/ WB15°C Outdoor: DB7°C/ WB 6°C

2. The Sound Pressure Level is based on the following conditions:

Outdoor unit:

Measure the noise value of 3 points, the points are 1 meter in front of the three sides of the unit surface (front/left/right) and height = $1/2(\text{unit height} + 1)$ meter from floor level, and calculate the weighted average of the noise.

Indoor unit:

Ceiling & Floor:

Test the noise value of the point 1.0m below the unit, 1.0m ahead of the unit and 1.0m high from the ground.

3. The above data was measured in an anechoic chamber. Please take into consideration reflected sound of your specific application environment.

4. All specifications are subjected to change by the manufacturer without prior notice.

2. SPECIFICATIONS

2.4 Console

Model				AKT-09UR4RRK4	AKT-12UR4RSK4	AKT-18UR4RSK4	
Indoor model				AKT-09UR4RK4	AKT-12UR4RK4	AKT-18UR4RK4	
Outdoor model				AUW-09U4RR4	AUW-12U4RS4	AUW-18U4RS4	
Electric parameter	Power supply	Indoor	V-ph-Hz	220-240/1/50	220-240/1/50	220-240/1/50	
	Power supply	Outdoor	V-ph-Hz	220-240/1/50	220-240/1/50	220-240/1/50	
	Input consumption	Max.	W	1400	1800	2400	
	Input current	Max.	A	6.1	8.1	11.6	
Seasonal efficiency	Cooling	Pdesignc	W	2900	3520	5000	
		SEER	W/W	6.51	6.52	6.50	
		Energy Efficiency Class	—	A++	A++	A++	
		Annual energy consumption	kWh/a	160	189	277	
	Heating (Average Season)	Pdesignh	W	2500	3520	4600	
		SCOP	W/W	4.2	4.1	4.1	
		Energy Efficiency Class	—	A+	A+	A+	
		Annual energy consumption	kWh/a	863	1203	1630	
	Tbiv	°C	-7	-7	-7		
	Tol	°C	-10	-10	-10		
Cooling	Capacity	Rated	Btu/h	10065	12010	17060	
		Rated	W	2950	3520	5000	
		Min - Max	W	1520~3670	1720~3850	1730~5430	
	Input	Rated	W	820	1005	1540	
	Current	Rated	A	4.3	4.5	7.2	
	EER	Rated	W/W	3.59	3.5	3.23	
Heating	Capacity	Rated	Btu/h	10407	12965	17401	
		Rated	kW	3.05	3.8	5100	
		Min - Max	W	1110~3550	1770~4220	2800~5600	
	Input	Rated	W	750	995	1374	
	Current	Rated	A	3.5	4.4	6.9	
	COP	Rated	W/W	4.06	3.82	3.71	
Indoor fan motor	Model		—	SIC-39CE-F130-1	SIC-39CE-F130-1	SIC-39CE-F130-1	
	Qty		—	1	1	1	
	Output		W	30	30	30	
	Capacitor		uF	—	—	—	
	Speed(Hi/Med/Lo)		r/min	590/490/400	620/510/410	720/620/520	
	Number of rows		—	2	2	2	
Indoor coil	Tube pitch(a)xrow pitch(b)		mm	21x13.6	21x13.6	21x13.6	
	Fin spacing		mm	1.3	1.3	1.3	
	Fin type		—	Hydrophilic aluminium	Hydrophilic aluminium	Hydrophilic aluminium	
	Tube outside dia.and type		mm	φ7,innergroove tube	φ7,innergroove tube	φ7,innergroove tube	
	Coil length x height x width		mm	509x399x27.2	509x399x27.2	509x399x27.2	
	Number of circuits		—	3	3	3	
	Indoor unit	Dimension		WxHxD	mm	700x630x220	700x630x220
Packing		WxHxD	mm	840x730x340	840x730x340		
Weight		Net/Gross	kg	15/19	15/19		
Air Volume		Hi/Med/Lo	m ³ /h	520/410/320	600/510/440	700/570/470	
		Hi/Med/Lo	CFM	309/244/190	353/300/259	417/339/280	
Sound Level (SPL)		Hi/Med/Lo	dB(A)	39/33/28	39/33/28	44/40/35	
Sound Level (PWL)		Hi	dB(A)	52	55	57	
External Static Pressure		Rated	Pa	—	—	—	
		Range	Pa	—	—	—	
Controller		Type	—	Wireless	Wireless	Wireless	
		Model	—	R2-01or others	R2-01 or others	R2-01 or others	
Drainage water pipe diameter		mm	ODφ18	ODφ18	ODφ18		
Drain pump		—	—	—	—		
Air filter		—	standard	standard	standard		
Throttle type		—	—	—	—		

2. SPECIFICATIONS

Model			AKT-09UR4RRK4	AKT-12UR4RSK4	AKT-18UR4RSK4
Indoor model			AKT-09UR4RK4	AKT-12UR4RK4	AKT-18UR4RK4
Outdoor model			AUW-09U4RR4	AUW-12U4RS4	AUW-18U4RS4
	Booster heater		kW	—	—
	Qty'per 20' /40' /40'HQ		—	154/308/308	154/308/308
	Design pressure	H/L	MPa	4.3/1.6	4.3/1.6
Room temperature	setting temperature	Cooling	°C	16 - 30	16 - 30
		Heating	°C	16 - 30	16 - 30
Compressor	Model		—	KSK103D59UFZ	KSN108D43UFZA
	Type		—	ROTARY	ROTARY
	Brand		—	GMCC	GMCC
	Capacity		Btu/h	11055	11635
	Input		W	835	855
	Rated current(RLA)		A	5.65	5.7
	Refrigerant oil	model	—	ESTER OIL VG74	ESTER OIL VG74
Amount		ml	320	310	
Outdoor fan motor	Model		—	SIC-52FV-F130-3	SIC-52FV-F130-3
	Qty		—	1	1
	Output		W	30	30
	Capacitor		μF	—	—
	Speed		r/min	820	880
Outdoor coil	Number of rows		—	1	2
	Tube pitch(a)x row pitch(b)		mm	21x21.65	21x18.19
	Fin spacing		mm	1.4	1.4
	Fin type		—	Hydrophilic aluminium	Hydrophilic aluminium
	Tube outside dia.and type		mm	Φ7.94, innergroove tube	Φ7,innergroove tube
	Coil length xheight xwidth		mm	790x504x21.65	840x546x36.38
Number of circuits		—	2	2	
Outdoor unit	Dimension	WxHxD	mm	730×540×260	810×585×280
	Packing	WxHxD	mm	860×590×400	940×420×640
	Weight	Net/Gross	kg	28.0/31.0	34/38.5
	Air Volume	Hi	m ³ /h	1850	2300
	Sound Level (SPL)	Hi	dB(A)	48	48
	Sound Level (PWL)	Hi	dB(A)	62	62
	Refrigerant	Type	—	R32	R32
		Amount	kg	0.75	0.85
		TCO2Eq	—	0.506	0.574
		GWP	—	675	675
Throttle type		—	EEV	EEV	
Qty'per 20' /40' /40'HQ		—	136/284/284	102/204/272	
Design pressure	H/L	MPa	4.3/1.6	4.3/1.6	
Refrigerant piping	Liquid/ Gas		mm(inch)	Φ6.35/Φ9.52(1/4/3/8')	Φ6.35/Φ9.52(1/4/3/8')
	Pipe length	Max.	m	25	25
	Height difference	Max. (OD lower)	m	15	15
		Max. (OD higher)	m	15	15
	ADD Refrigerant AMOUNT		g/m	12	12
PIPE LENGTH FOR ADDITIONAL		m	5	5	
Operating (Outdoor Range)	Cooling		°C	-15~48	-15~48
	Heating		°C	-15~24	-15~24

NOTE:

1. Test conditions:

Cooling : Indoor: DB27°C/ WB19°C Outdoor: DB35°C/ WB24°C

Heating: Indoor: DB20°C/ WB15°C Outdoor: DB7°C/ WB 6°C

2. The Sound Pressure Level is based on the following conditions:

Outdoor unit:

Measure the noise value of 3 points, the points are 1 meter in front of the three sides of the unit surface (front/left/right) and height =1/2(unit height +1) meter from floor level, and calculate the weighted average of the noise. Indoor unit:

Console:

Test the noise value of the point 1.0m ahead of the unit and 1.0m high from the unit.

3. The above data was measured in an anechoic chamber. Please take into consideration reflected sound of your specific application environment.

4. All specifications are subjected to change by the manufacturer without prior notice.

3. OUTLINES AND DIMENSIONS

3. Outlines and dimensions

3.1 Indoor units

Duct

9K/12K/18K/24K

Unit: mm

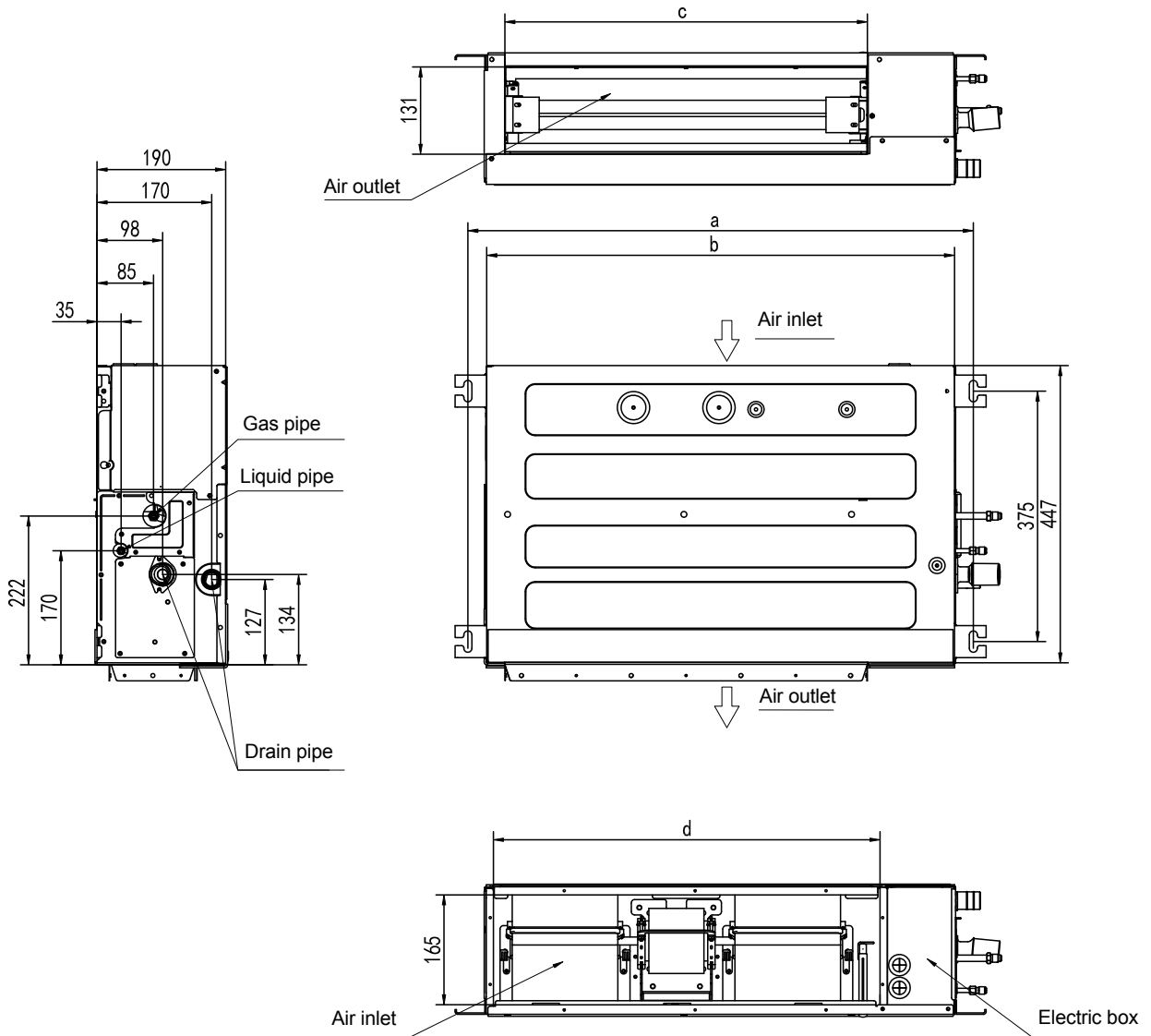

Model (Btu/h)	a	b	c	d
9K/12K	961	910	749	786
18K/24K	1231	1180	1019	1056

3. OUTLINES AND DIMENSIONS

30K/36K

Unit: mm

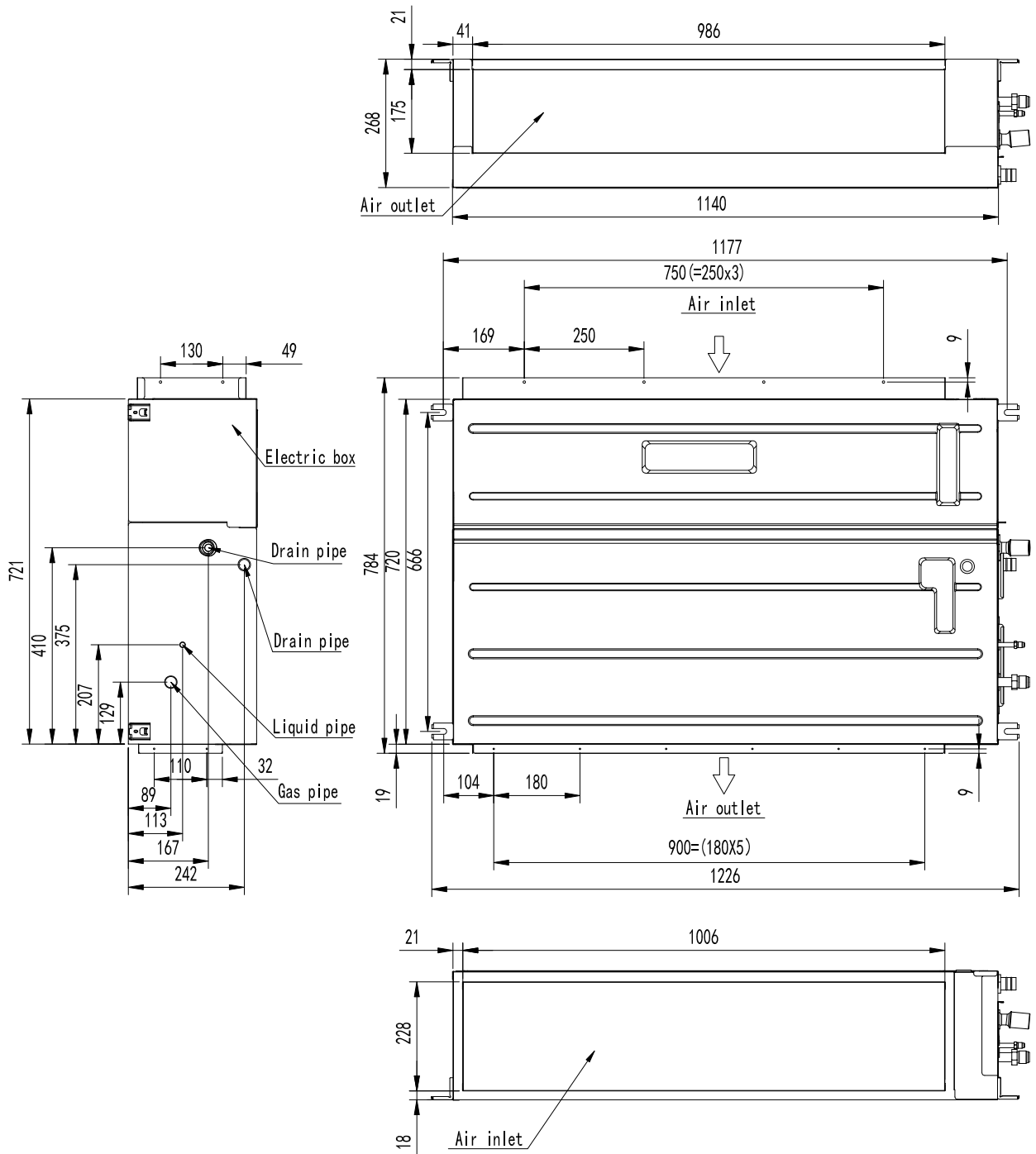

3. OUTLINES AND DIMENSIONS

42K/48K/60K

Unit: mm

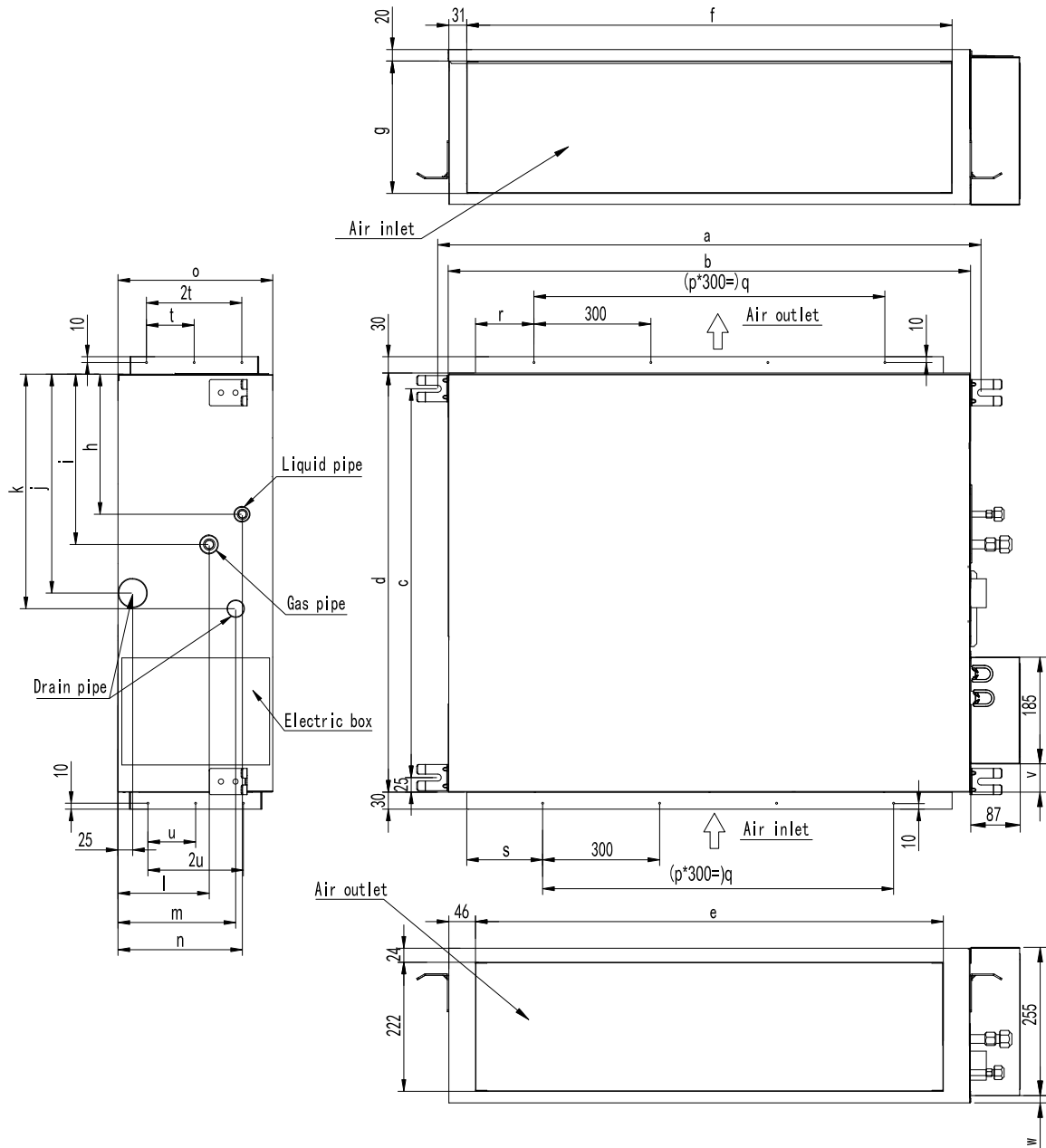

Model	a	b	c	d	e	f	g	h	i	j	k	l	m	n	o	p	q	r	s	t	u	v	w
42K/48K/ 60K	1334	1300	756	800	1205	1235	308	237	312	375	400	204	186	242	350	3	900	153	168	90	140	110	49

3. OUTLINES AND DIMENSIONS

Cassette

9K~18K

Unit: mm

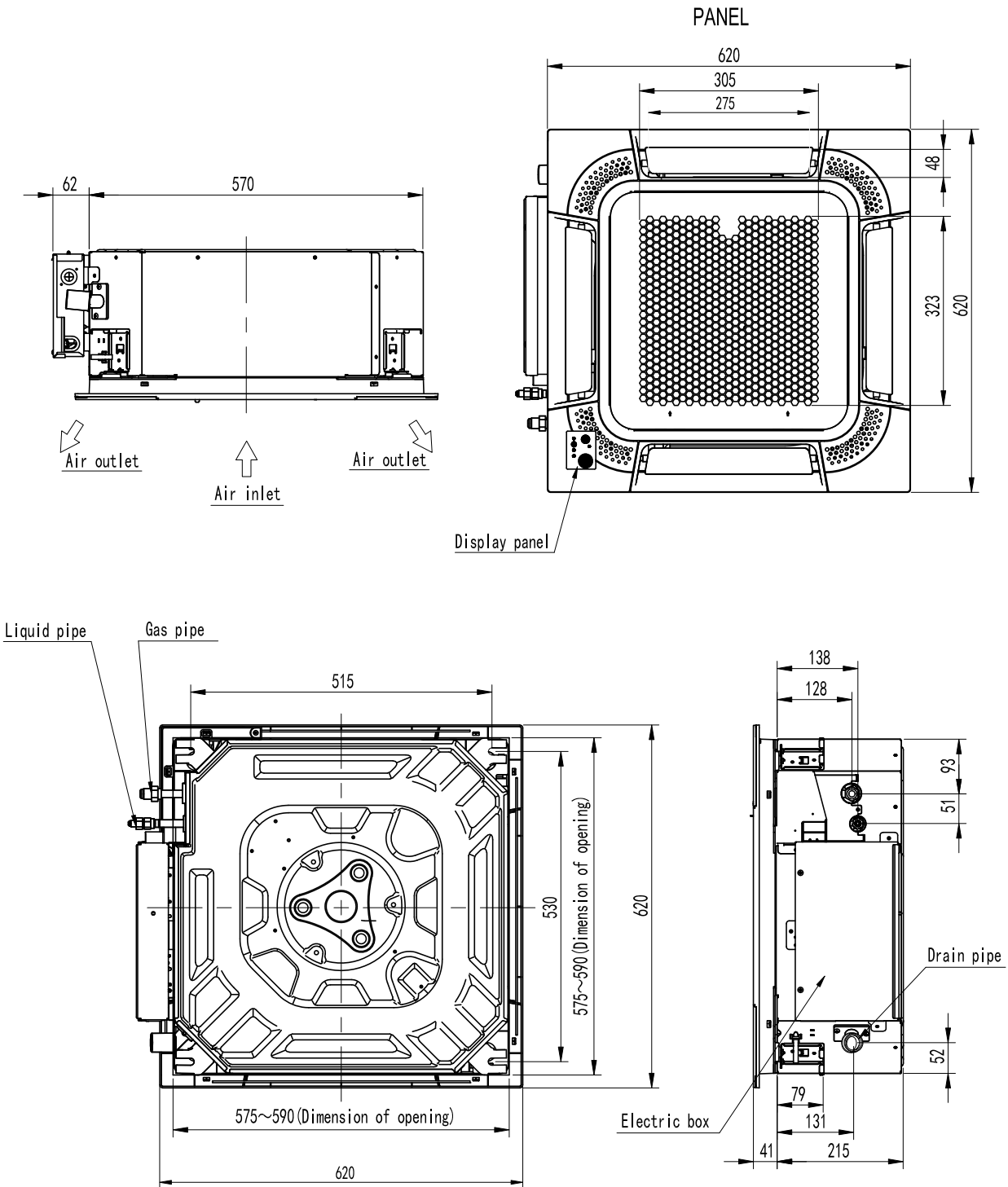

3. OUTLINES AND DIMENSIONS

24K~60K

Unit: mm

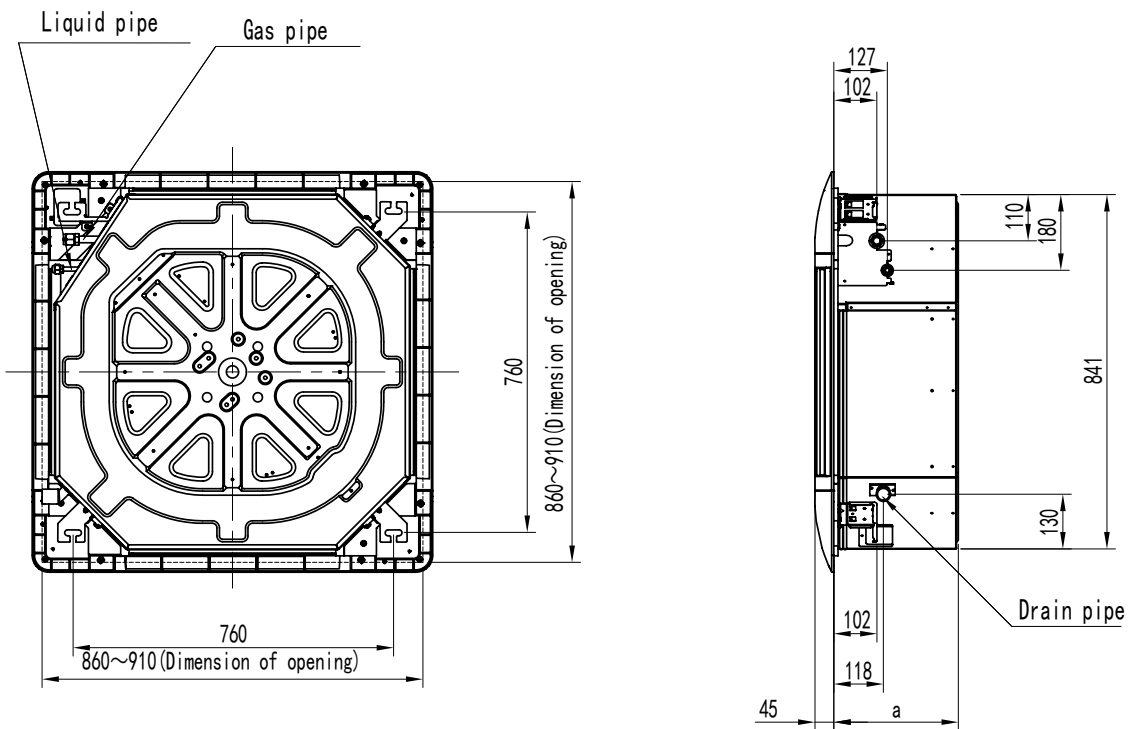
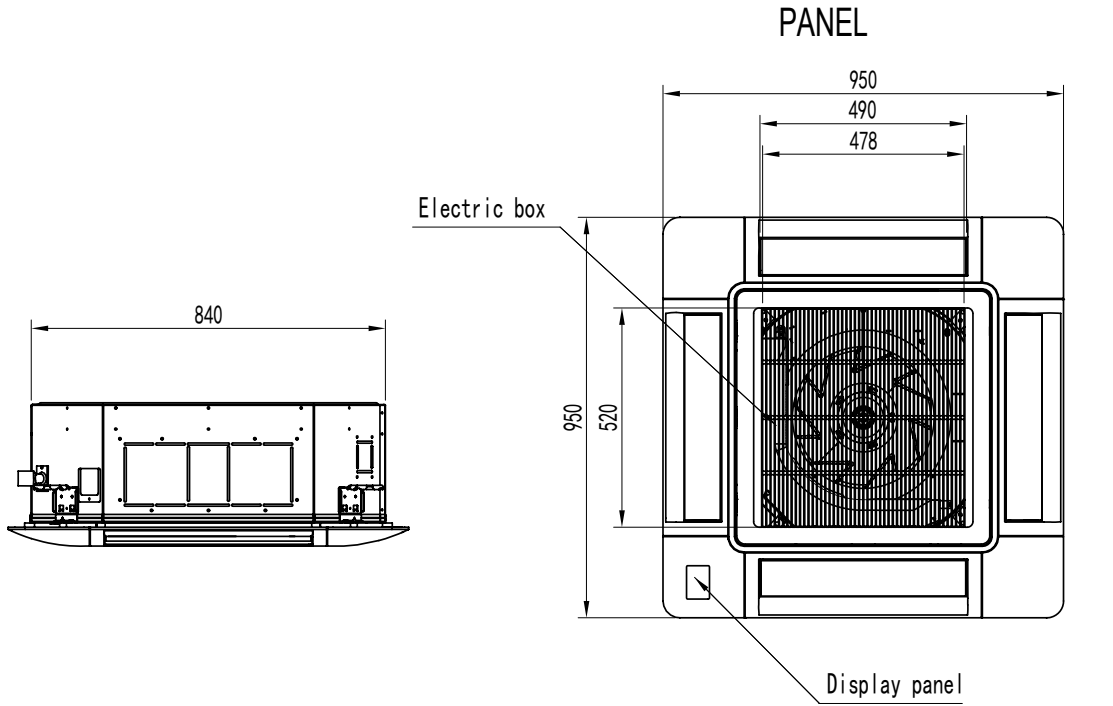

Model	a
24K/30K/36K	248
42K/48K/60K	298

3. OUTLINES AND DIMENSIONS

Ceiling & Floor

Unit: mm

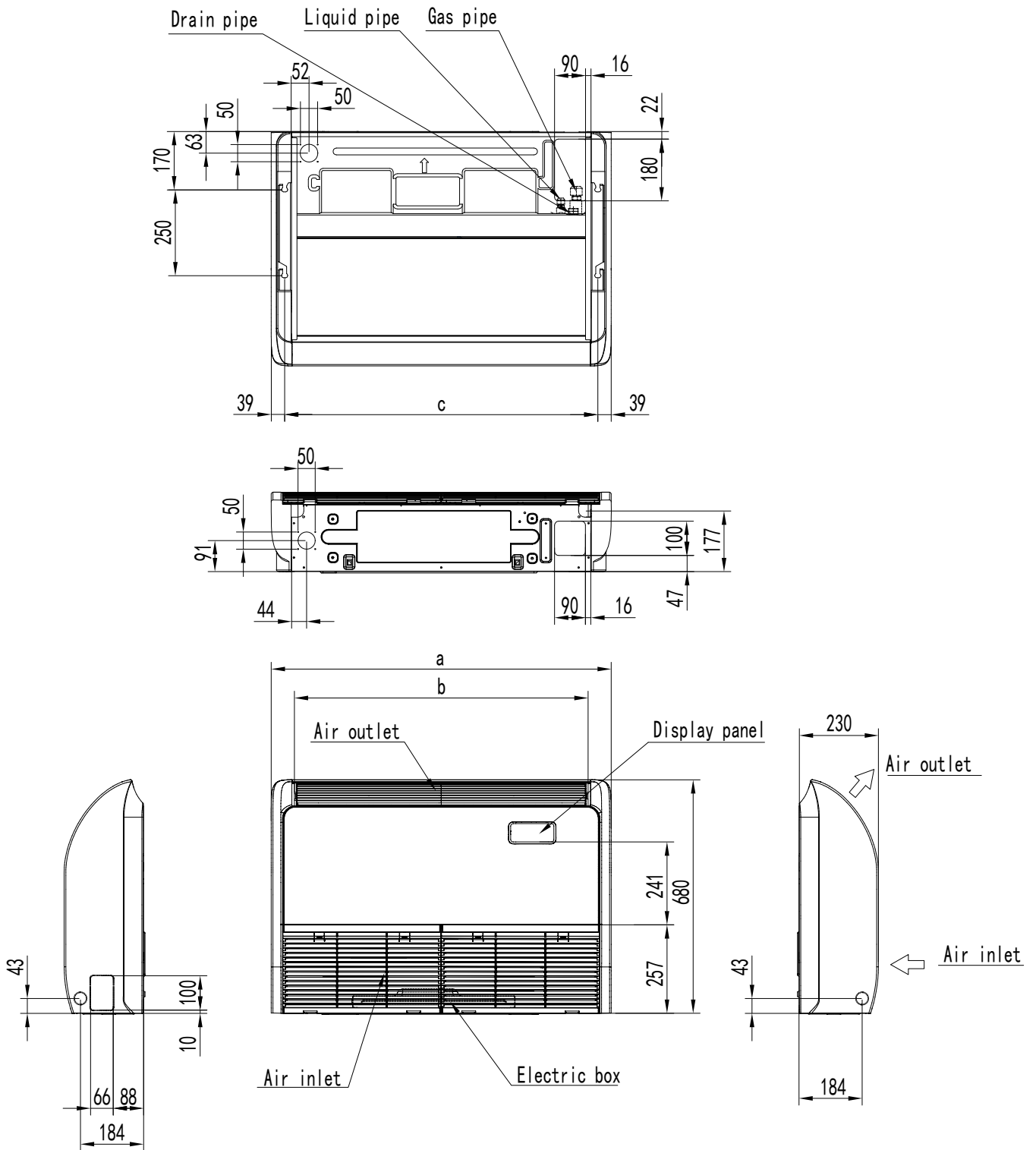

Model	a	b	c
18K/24K	990	855	912
30K/36K	1285	1150	1207
42K/48K/60K	1580	1445	1502

3. OUTLINES AND DIMENSIONS

Console

Unit: mm

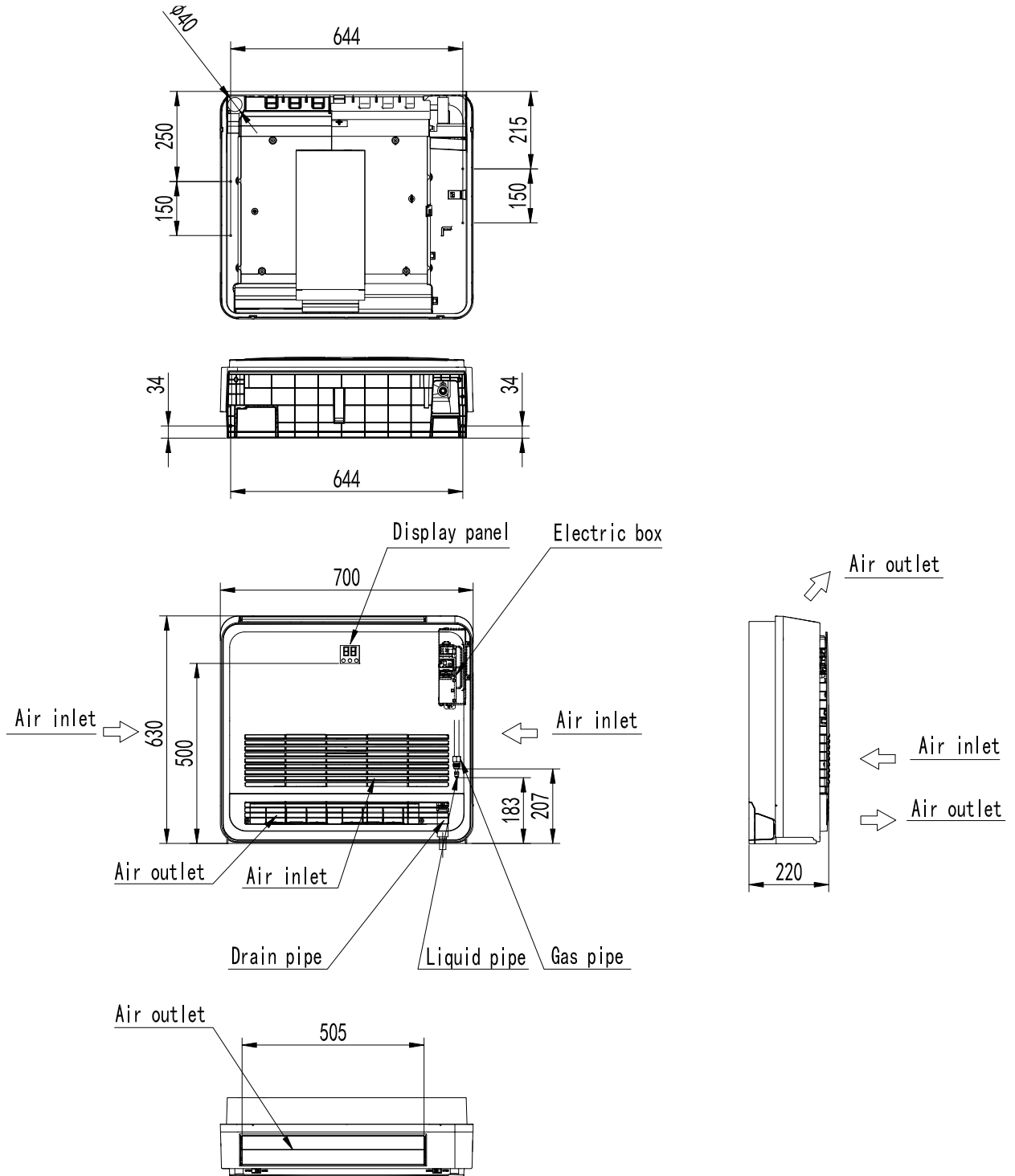

3. OUTLINES AND DIMENSIONS

3.2 Outdoor units

9K

Unit: mm

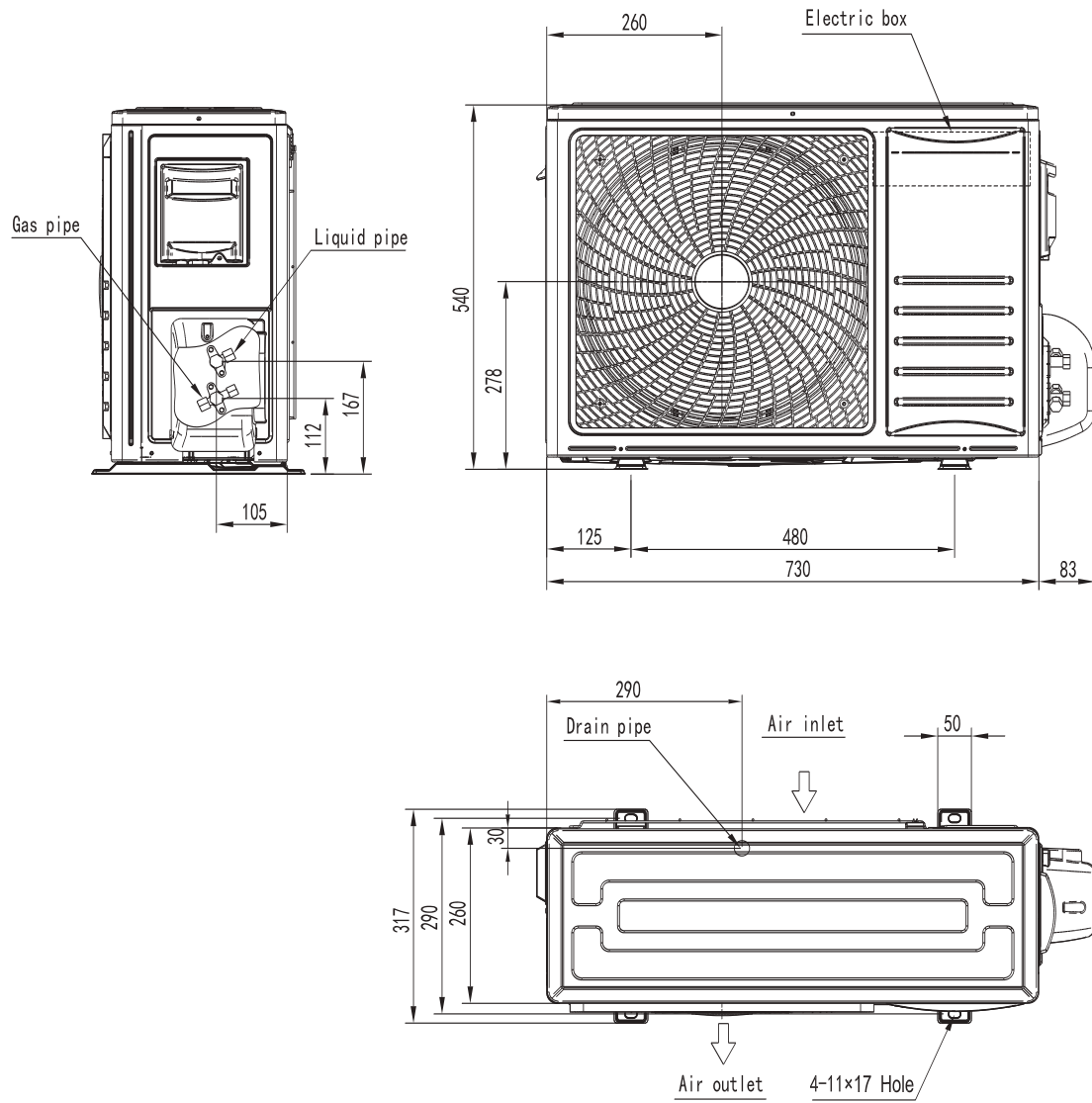

3. OUTLINES AND DIMENSIONS

12K/18K

Unit: mm

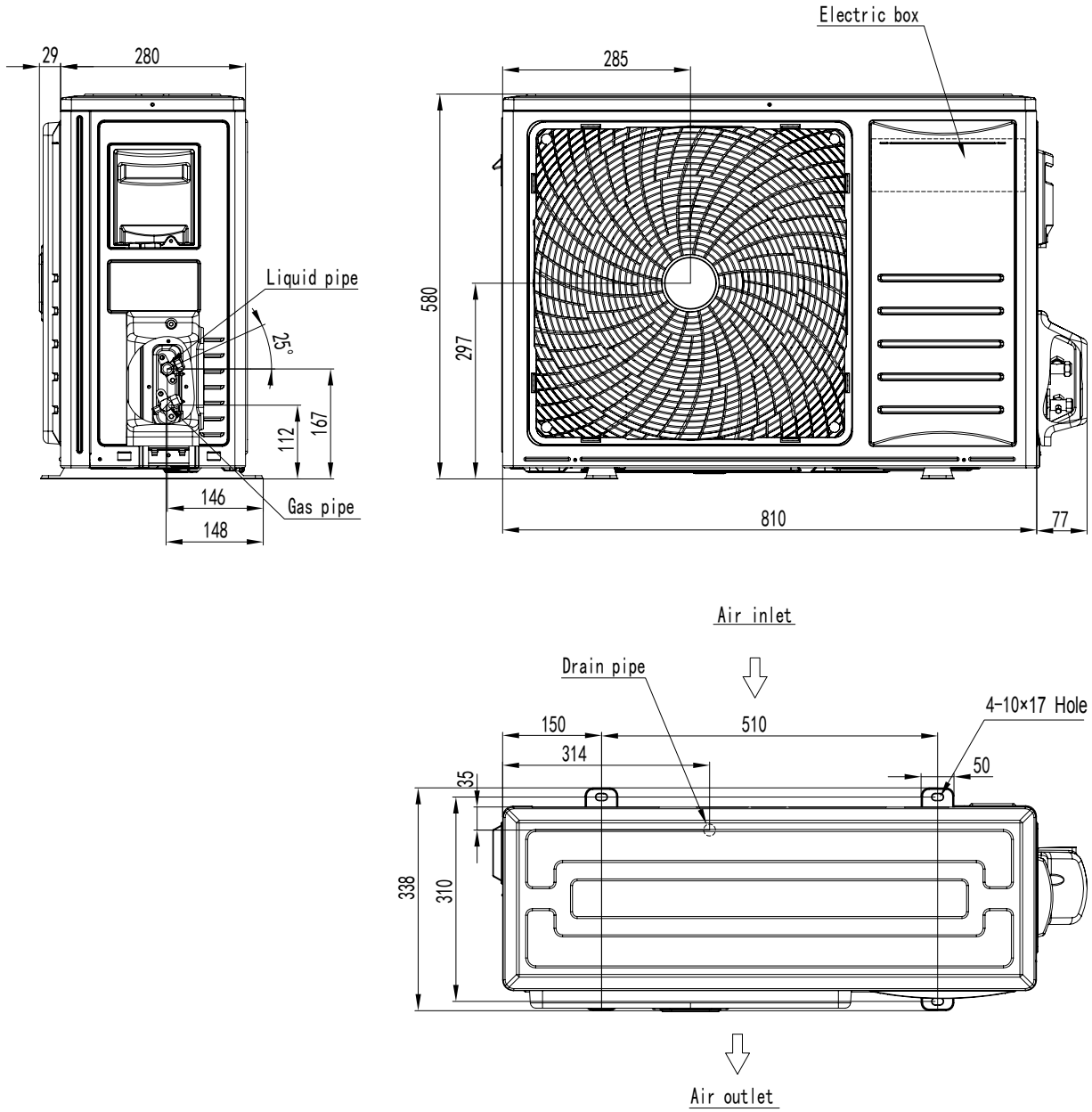

3. OUTLINES AND DIMENSIONS

24K/30K

Unit: mm

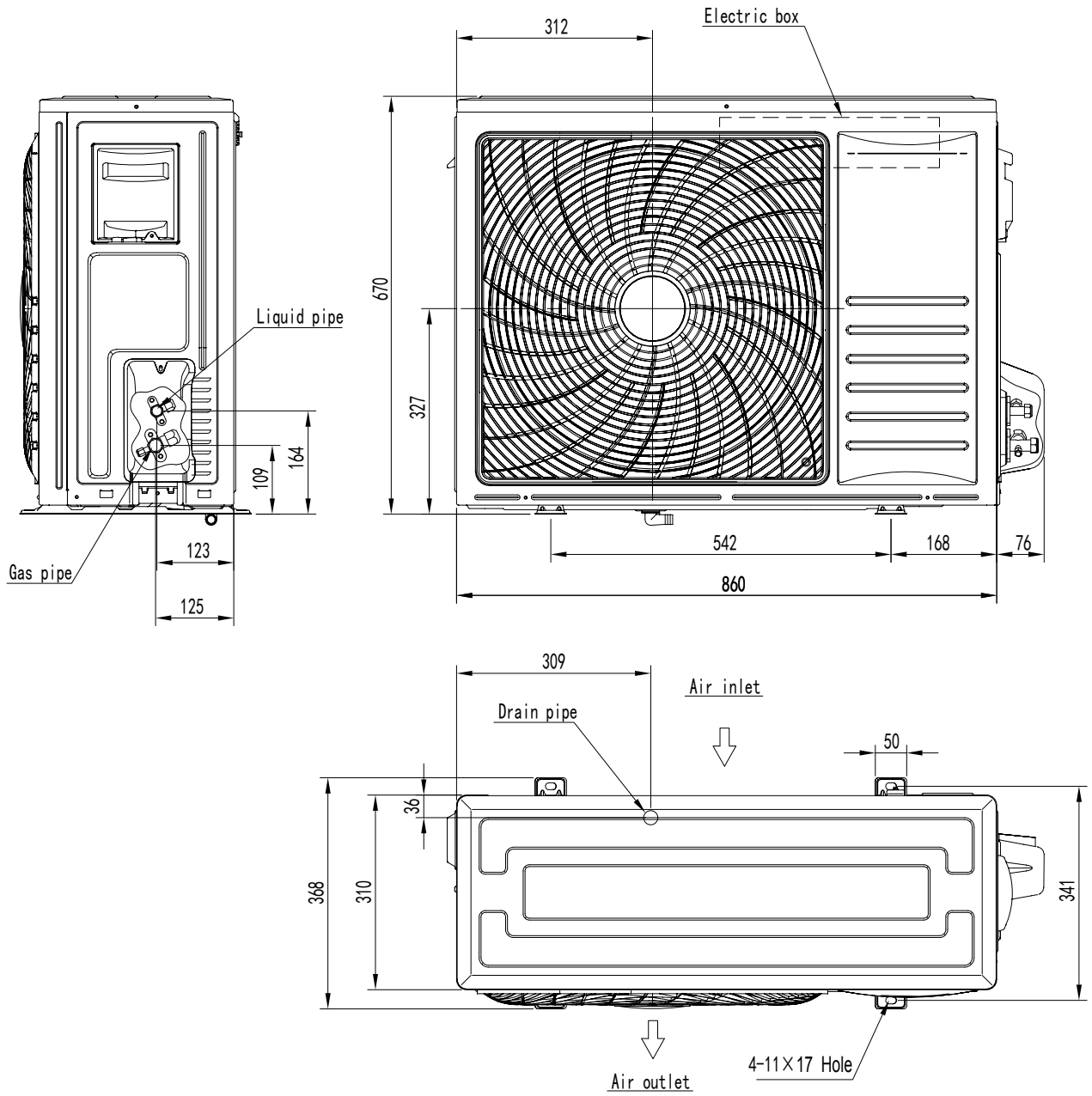

3. OUTLINES AND DIMENSIONS

36K

Unit: mm

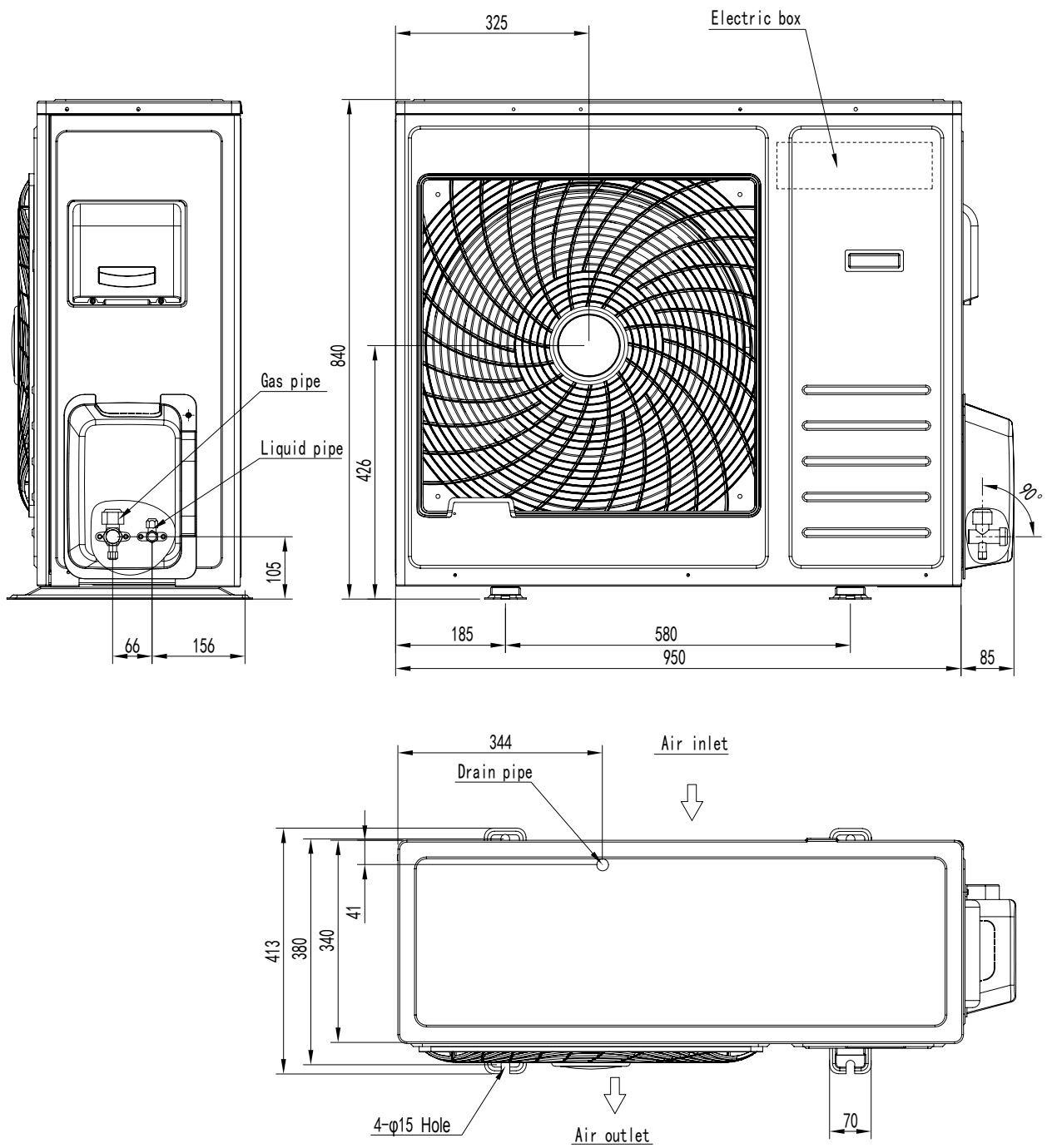

3. OUTLINES AND DIMENSIONS

42K

Unit: mm

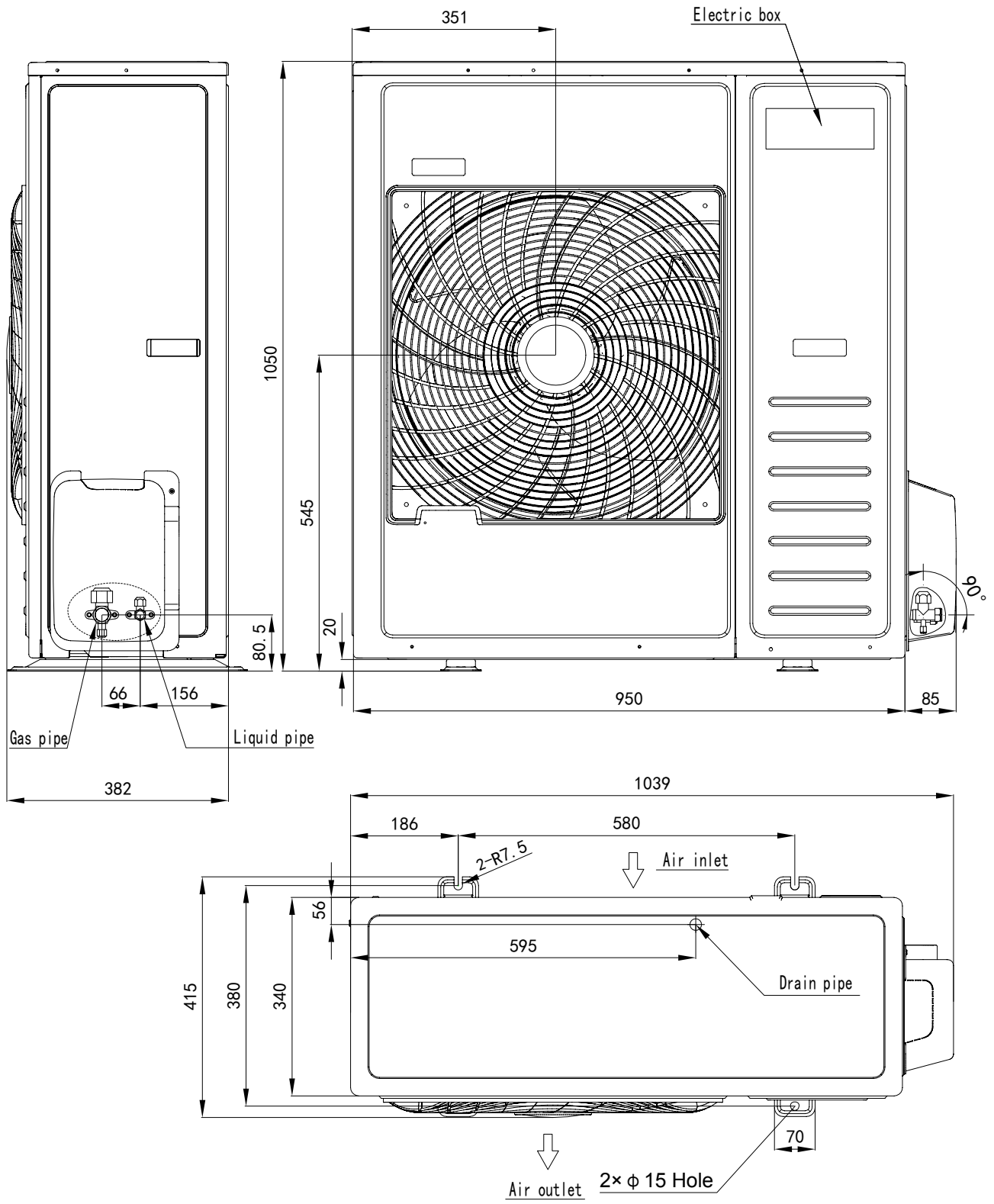

3. OUTLINES AND DIMENSIONS

48K/60K

Unit: mm

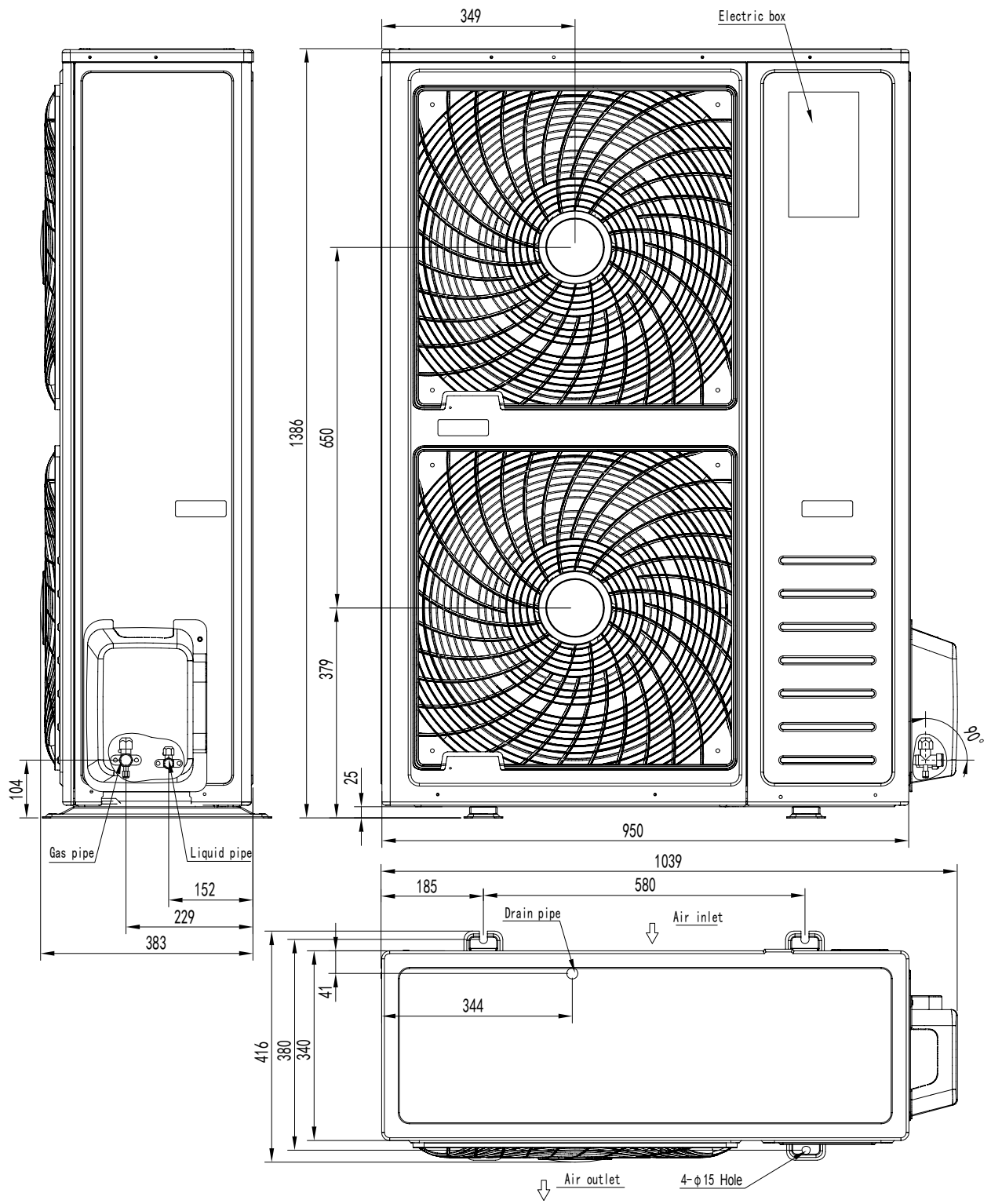

4. ELECTRICAL DATA

4. Electrical data

Outdoor unit	Power supply			Applicable voltage		ELB	
	Voltage(V)	PH	Frequency (Hz)	Umin(V)	Umax(V)	Nominal Current(A)	Nominal Sensitive Current(mA)
9K/12K	220-240	1	50	176	264	20	30
24K/30K	220-240	1	50	176	264	25	30
36K	220-240	1	50	176	264	40	30
42K/48K/60K	380-415	3	50	342	438	32	30

NOTE:

1. The above compressor data is based on 100% capacity combination of indoor units at the rated operating frequency.
2. This data is based on the same conditions as the nominal heating and cooling capacities.
3. The compressor started by an inverter, resulting in extremely low starting current.

5. CAPACITIES AND SELECTION DATA

5. Capacities and selection data

5.1 Capacity characteristic charts

The following charts show the characteristics of outdoor unit capacity, which corresponds with the operating ambient temperature of outdoor unit.

Conditions:

- ① Pipe length / height difference : 5m / 0m
- ② Compressor at rated inverter frequency
- ③ Indoor fan speed at high fan speed
- ④ Capacity loss due to white frost and defrost operation is not included.

Duct

9K

COOLING CAPACITY(kW)

Indoor temperature		Outdoor temperature (°CDB)					
(°C WB)	(°C DB)	20	25	32	35	40	45
14	20	2.55	2.49	2.32	2.26	2.09	1.97
16	22	2.78	2.67	2.61	2.44	2.26	2.15
18	25	2.90	2.78	2.84	2.67	2.55	2.44
19	27	3.13	3.02	2.96	2.90	2.78	2.73
19.5	27	3.19	3.07	3.02	2.96	2.84	2.78
22	30	3.65	3.42	3.31	3.19	3.07	2.90
24	32	3.94	3.83	3.71	3.65	3.42	3.13

(°C DB) : Dry Bulb Temperature (°C)

(°C WB) : Wet Bulb Temperature (°C)

HEATING CAPACITY (kW)

Outdoor temperature		Indoor temperature (°CDB)						
(°C WB)	(°C DB)	20	25	27	28	30	31	32
-16	-15	1.88	1.88	1.78	1.78	1.68	1.68	1.68
-11	-10	2.08	2.08	1.98	1.98	1.88	1.88	1.88
-6	-5	2.44	2.44	2.34	2.34	2.34	2.24	2.24
-1	0	2.80	2.80	2.64	2.64	2.54	2.54	2.54
6	7	3.10	3.10	3.10	3.10	3.10	3.10	3.00
9	10	3.20	3.15	3.15	3.15	3.15	3.15	3.10
14	15	3.30	3.20	3.20	3.20	3.20	3.20	3.15

(°C DB) : Dry Bulb Temperature (°C)

(°C WB) : Wet Bulb Temperature (°C)

5. CAPACITIES AND SELECTION DATA

12K

COOLING CAPACITY(kW)

Indoor temperature		Outdoor temperature (°CDB)					
(°C WB)	(°C DB)	20	25	32	35	40	45
14	20	3.1	3.0	2.8	2.7	2.5	2.4
16	22	3.4	3.2	3.2	3.0	2.7	2.6
18	25	3.5	3.4	3.4	3.2	3.1	3.0
19	27	3.8	3.7	3.6	3.5	3.4	3.3
19.5	27	3.9	3.7	3.7	3.6	3.4	3.4
22	30	4.4	4.2	4.0	3.9	3.7	3.5
24	32	4.8	4.6	4.5	4.4	4.2	3.8

(°C DB) : Dry Bulb Temperature (°C)

(°C WB) : Wet Bulb Temperature (°C)

HEATING CAPACITY (kW)

Outdoor temperature		Indoor temperature (°CDB)						
(°C WB)	(°C DB)	20	25	27	28	30	31	32
-16	-15	2.3	2.3	2.2	2.2	2.1	2.1	2.1
-11	-10	2.6	2.6	2.4	2.4	2.3	2.3	2.3
-6	-5	3.0	3.0	2.9	2.9	2.9	2.7	2.7
-1	0	3.4	3.4	3.2	3.2	3.1	3.1	3.1
6	7	3.8	3.8	3.8	3.8	3.8	3.8	3.7
9	10	3.9	3.9	3.9	3.9	3.9	3.9	3.8
14	15	4.0	3.9	3.9	3.9	3.9	3.9	3.9

(°C DB) : Dry Bulb Temperature (°C)

(°C WB) : Wet Bulb Temperature (°C)

18K

COOLING CAPACITY(kW)

Indoor temperature		Outdoor temperature (°CDB)					
(°C WB)	(°C DB)	20	25	32	35	40	45
14	20	4.66	4.56	4.24	4.13	3.82	3.60
16	22	5.09	4.88	4.77	4.45	4.13	3.92
18	25	5.30	5.09	5.19	4.88	4.66	4.45
19	27	5.72	5.51	5.41	5.30	5.09	4.98
19.5	27	5.83	5.62	5.51	5.41	5.19	5.09
22	30	6.68	6.25	6.04	5.83	5.62	5.30
24	32	7.21	7.00	6.78	6.68	6.25	5.72

(°C DB) : Dry Bulb Temperature (°C)

(°C WB) : Wet Bulb Temperature (°C)

5. CAPACITIES AND SELECTION DATA

HEATING CAPACITY (kW)

Outdoor temperature		Indoor temperature (°CDB)						
(°C WB)	(°C DB)	20	25	27	28	30	31	32
-16	-15	3.52	3.52	3.33	3.33	3.14	3.14	3.14
-11	-10	3.90	3.90	3.71	3.71	3.52	3.52	3.52
-6	-5	4.56	4.56	4.37	4.37	4.37	4.18	4.18
-1	0	5.23	5.23	4.94	4.94	4.75	4.75	4.75
6	7	5.80	5.80	5.80	5.80	5.80	5.80	5.61
9	10	5.99	5.90	5.90	5.90	5.90	5.90	5.80
14	15	6.18	5.99	5.99	5.99	5.99	5.99	5.90

(°C DB) : Dry Bulb Temperature (°C)

(°C WB) : Wet Bulb Temperature (°C)

24K

COOLING CAPACITY (kW)

Indoor temperature		Outdoor temperature (°C DB)					
(°C WB)	(°C DB)	20	25	32	35	40	45
14	20	6.3	6.2	5.8	5.6	5.2	4.9
16	22	6.9	6.6	6.5	6.0	5.6	5.3
18	25	7.2	6.9	7.1	6.6	6.3	6.0
19	27	7.8	7.5	7.3	7.2	6.9	6.8
19.5	27	7.9	7.6	7.5	7.3	7.1	6.9
22	30	9.1	8.5	8.2	7.9	7.6	7.2
24	32	9.8	9.5	9.2	9.1	8.5	7.8

(°C DB) : Dry Bulb Temperature (°C)

(°C WB) : Wet Bulb Temperature (°C)

HEATING CAPACITY (kW)

Outdoor temperature		Indoor temperature (°C DB)						
(°C WB)	(°C DB)	20	25	27	28	30	31	32
-16	-15	4.8	4.8	4.5	4.5	4.3	4.3	4.3
-11	-10	5.3	5.3	5.1	5.1	4.8	4.8	4.8
-6	-5	6.2	6.2	6.0	6.0	6.0	5.7	5.7
-1	0	7.1	7.1	6.7	6.7	6.5	6.5	6.5
6	7	7.9	7.9	7.9	7.9	7.9	7.9	7.6
9	10	8.2	8.0	8.0	8.0	8.0	8.0	7.9
14	15	8.4	8.2	8.2	8.2	8.2	8.2	8.0

(°C DB) : Dry Bulb Temperature (°C)

(°C WB) : Wet Bulb Temperature (°C)

5. CAPACITIES AND SELECTION DATA

30K

COOLING CAPACITY (kW)

Indoor temperature		Outdoor temperature (°CDB)					
(°C WB)	(°C DB)	20	25	32	35	40	45
14	20	7.7	7.6	7.0	6.9	6.3	6.2
16	22	8.4	8.1	7.9	7.4	6.9	6.7
18	25	8.8	8.4	8.6	8.1	7.7	7.6
19	27	9.5	9.2	9.0	8.8	8.4	8.4
19.5	27	9.7	9.3	9.2	9.0	8.6	8.5
22	30	11.1	10.4	10.0	9.7	9.3	9.1
24	32	12.0	11.6	11.3	11.1	10.4	9.9

(°C DB) : Dry Bulb Temperature (°C)

(°C WB) : Wet Bulb Temperature (°C)

HEATING CAPACITY (kW)

Outdoor temperature		Indoor temperature (°CDB)						
(°C WB)	(°C DB)	20	25	27	28	30	31	32
-16	-15	5.5	5.5	5.2	5.2	4.9	4.9	4.9
-11	-10	6.0	6.0	5.8	5.8	5.5	5.5	5.5
-6	-5	7.1	7.1	6.8	6.8	6.8	6.5	6.5
-1	0	8.1	8.1	7.7	7.7	7.4	7.4	7.4
6	7	9.0	8.8	8.8	8.8	8.7	8.7	8.7
9	10	9.3	9.1	9.1	9.1	9.1	9.1	9.0
14	15	9.6	9.3	9.3	9.3	9.3	9.3	9.1

(°C DB) : Dry Bulb Temperature (°C)

(°C WB) : Wet Bulb Temperature (°C)

36K

COOLING CAPACITY (kW)

Indoor temperature		Outdoor temperature (°C DB)					
(°CWB)	(°CDB)	20	25	32	35	40	45
14	20	10.2	10	9.8	9.5	9.0	8.0
16	22	10.6	10.5	10	10	9.4	8.4
18	25	11	10.8	10.6	10.2	9.8	8.8
19	27	11.5	11.2	10.7	10.5	9.9	9.0
19.5	27	11.6	11.4	11	10.7	10.2	9.4
22	30	11.8	11.6	11.2	10.9	10.6	9.8
24	32	12	11.8	11.4	11.2	10.8	10.1

(°C DB) : Dry Bulb Temperature (°C)

(°C WB) : Wet Bulb Temperature (°C)

5. CAPACITIES AND SELECTION DATA

42K

COOLING CAPACITY (kW)

Indoor temperature		Outdoor temperature (°CDB)					
(°C WB)	(°C DB)	20	25	32	35	40	45
14	20	11.1	10.7	10.0	9.6	8.9	8.6
16	22	12.1	11.4	11.4	10.7	9.6	9.3
18	25	12.5	12.1	12.1	11.4	11.1	10.7
19	27	13.6	13.2	12.9	12.5	12.1	11.8
19.5	27	13.9	13.2	13.2	12.9	12.1	12.1
22	30	15.7	15.0	14.3	13.9	13.2	12.5
24	32	17.1	16.4	16.1	15.7	15.0	13.6

(°C DB) : Dry Bulb Temperature (°C)

(°C WB) : Wet Bulb Temperature (°C)

HEATING CAPACITY (kW)

Outdoor temperature		Indoor temperature (°CDB)						
(°C WB)	(°C DB)	20	25	27	28	30	31	32
-16	-15	8.1	8.1	7.7	7.7	7.2	7.2	7.2
-11	-10	9.0	9.0	8.6	8.6	8.1	8.1	8.1
-6	-5	10.5	10.5	10.1	10.1	10.1	9.7	9.7
-1	0	12.1	12.1	11.4	11.4	11.0	11.0	11.0
6	7	13.4	13.4	13.4	13.4	13.4	13.4	13.0
9	10	13.8	13.6	13.6	13.6	13.6	13.6	13.4
14	15	14.3	13.8	13.8	13.8	13.8	13.8	13.6

(°C DB) : Dry Bulb Temperature (°C)

(°C WB) : Wet Bulb Temperature (°C)

48K

COOLING CAPACITY (kW)

Indoor temperature		Outdoor temperature (°C DB)					
(°C WB)	(°C DB)	20	25	32	35	40	45
14	20	12.7	12.4	11.5	11.2	10.4	9.8
16	22	13.8	13.2	13.0	12.1	11.2	10.7
18	25	14.4	13.8	14.1	13.2	12.7	12.1
19	27	15.6	15.0	14.7	14.4	13.8	13.5
19.5	27	15.8	15.3	15.0	14.7	14.1	13.8
22	30	18.1	17.0	16.4	15.8	15.3	14.4
24	32	19.6	19.0	18.4	18.1	17.0	15.6

(°C DB) : Dry Bulb Temperature (°C)

(°C WB) : Wet Bulb Temperature (°C)

5. CAPACITIES AND SELECTION DATA

HEATING CAPACITY (kW)

Outdoor temperature		Indoor temperature (°C DB)						
(°C WB)	(°C DB)	20	25	27	28	30	31	32
-16	-15	10.5	10.5	9.9	9.9	9.4	9.4	9.4
-11	-10	11.6	11.6	11.1	11.1	10.5	10.5	10.5
-6	-5	13.6	13.6	13.0	13.0	13.0	12.5	12.5
-1	0	15.6	15.6	14.7	14.7	14.2	14.2	14.2
6	7	17.3	17.3	17.3	17.3	17.3	17.3	16.7
9	10	17.9	17.6	17.6	17.6	17.6	17.6	17.3
14	15	18.4	17.9	17.9	17.9	17.9	17.9	17.6

(°C DB) : Dry Bulb Temperature (°C)

(°C WB) : Wet Bulb Temperature (°C)

60K

COOLING CAPACITY (kW)

Indoor temperature		Outdoor temperature (°C DB)					
(°C WB)	(°C DB)	20	25	32	35	40	45
14	20	15.4	15.1	14.0	13.7	12.6	11.9
16	22	16.8	16.1	15.8	14.7	13.7	13.0
18	25	17.5	16.8	17.2	16.1	15.4	14.7
19	27	18.9	18.2	17.9	17.5	16.8	16.5
19.5	27	19.3	18.6	18.2	17.9	17.2	16.8
22	30	22.1	20.7	20.0	19.3	18.6	17.5
24	32	23.8	23.1	22.4	22.1	20.7	18.9

(°C DB) : Dry Bulb Temperature (°C)

(°C WB) : Wet Bulb Temperature (°C)

HEATING CAPACITY (kW)

Outdoor temperature		Indoor temperature (°C DB)						
(°C WB)	(°C DB)	20	25	27	28	30	31	32
-16	-15	11.2	11.2	10.6	10.6	10.0	10.0	10.0
-11	-10	12.4	12.4	11.8	11.8	11.2	11.2	11.2
-6	-5	14.6	14.6	14.0	14.0	14.0	13.3	13.3
-1	0	16.7	16.7	15.8	15.8	15.2	15.2	15.2
6	7	18.5	18.5	18.5	18.5	18.5	18.5	17.9
9	10	19.1	18.8	18.8	18.8	18.8	18.8	18.5
14	15	19.7	19.1	19.1	19.1	19.1	19.1	18.8

(°C DB) : Dry Bulb Temperature (°C)

(°C WB) : Wet Bulb Temperature (°C)

5. CAPACITIES AND SELECTION DATA

Cassette

9K

COOLING CAPACITY (kW)

Indoor temperature		Outdoor temperature (°CDB)					
(°C WB)	(°C DB)	20	25	32	35	40	45
14	20	2.50	2.44	2.27	2.22	2.04	1.93
16	22	2.73	2.61	2.56	2.39	2.22	2.10
18	25	2.84	2.73	2.78	2.61	2.50	2.39
19	27	3.07	2.95	2.90	2.84	2.73	2.67
19.5	27	3.12	3.01	2.95	2.90	2.78	2.73
22	30	3.58	3.35	3.24	3.12	3.01	2.84
24	32	3.86	3.75	3.64	3.58	3.35	3.07

(°C DB) : Dry Bulb Temperature (°C)

(°C WB) : Wet Bulb Temperature (°C)

HEATING CAPACITY (kW)

Outdoor temperature		Indoor temperature (°CDB)						
(°C WB)	(°C DB)	20	25	27	28	30	31	32
-16	-15	1.90	1.90	1.80	1.80	1.69	1.69	1.69
-11	-10	2.10	2.10	2.00	2.00	1.90	1.90	1.90
-6	-5	2.46	2.46	2.36	2.36	2.36	2.26	2.26
-1	0	2.82	2.82	2.67	2.67	2.57	2.57	2.57
6	7	3.13	3.13	3.13	3.13	3.13	3.13	3.03
9	10	3.23	3.18	3.18	3.18	3.18	3.18	3.13
14	15	3.34	3.23	3.23	3.23	3.23	3.23	3.18

(°C DB) : Dry Bulb Temperature (°C)

(°C WB) : Wet Bulb Temperature (°C)

12K

COOLING CAPACITY (kW)

Indoor temperature		Outdoor temperature (°CDB)					
(°C WB)	(°C DB)	20	25	32	35	40	45
14	20	3.3	3.2	3.0	2.9	2.7	2.6
16	22	3.6	3.5	3.4	3.2	2.9	2.8
18	25	3.8	3.6	3.7	3.5	3.3	3.2
19	27	4.1	3.9	3.8	3.8	3.6	3.5
19.5	27	4.1	4.0	3.9	3.8	3.7	3.6
22	30	4.7	4.4	4.3	4.1	4.0	3.8
24	32	5.1	5.0	4.8	4.7	4.4	4.1

(°C DB) : Dry Bulb Temperature (°C)

(°C WB) : Wet Bulb Temperature (°C)

5. CAPACITIES AND SELECTION DATA

HEATING CAPACITY (kW)

Outdoor temperature		Indoor temperature (°CDB)						
(°C WB)	(°C DB)	20	25	27	28	30	31	32
-16	-15	2.4	2.4	2.3	2.3	2.2	2.2	2.2
-11	-10	2.7	2.7	2.6	2.6	2.4	2.4	2.4
-6	-5	3.1	3.1	3.0	3.0	3.0	2.9	2.9
-1	0	3.6	3.6	3.4	3.4	3.3	3.3	3.3
6	7	4.0	4.0	4.0	4.0	4.0	4.0	3.9
9	10	4.1	4.1	4.1	4.1	4.1	4.1	4.0
14	15	4.3	4.1	4.1	4.1	4.1	4.1	4.1

(°C DB) : Dry Bulb Temperature (°C)

(°C WB) : Wet Bulb Temperature (°C)

18K

COOLING CAPACITY (kW)

Indoor temperature		Outdoor temperature (°CDB)					
(°C WB)	(°C DB)	20	25	32	35	40	45
14	20	4.58	4.47	4.16	4.06	3.74	3.54
16	22	4.99	4.78	4.68	4.37	4.06	3.85
18	25	5.20	4.99	5.10	4.78	4.58	4.37
19	27	5.62	5.41	5.30	5.20	4.99	4.89
19.5	27	5.72	5.51	5.41	5.30	5.10	4.99
22	30	6.55	6.14	5.93	5.72	5.51	5.20
24	32	7.07	6.86	6.66	6.55	6.14	5.62

(°C DB) : Dry Bulb Temperature (°C)

(°C WB) : Wet Bulb Temperature (°C)

HEATING CAPACITY (kW)

Outdoor temperature		Indoor temperature (°CDB)						
(°C WB)	(°C DB)	20	25	27	28	30	31	32
-16	-15	3.58	3.58	3.39	3.39	3.19	3.19	3.19
-11	-10	3.97	3.97	3.77	3.77	3.58	3.58	3.58
-6	-5	4.64	4.64	4.45	4.45	4.45	4.26	4.26
-1	0	5.32	5.32	5.03	5.03	4.84	4.84	4.84
6	7	5.90	5.90	5.90	5.90	5.90	5.90	5.71
9	10	6.09	6.00	6.00	6.00	6.00	6.00	5.90
14	15	6.29	6.09	6.09	6.09	6.09	6.09	6.00

(°C DB) : Dry Bulb Temperature (°C)

(°C WB) : Wet Bulb Temperature (°C)

5. CAPACITIES AND SELECTION DATA

24K

COOLING CAPACITY (kW)

Indoor temperature		Outdoor temperature (°C DB)					
(°C WB)	(°C DB)	20	25	32	35	40	45
14	20	6.4	6.3	5.8	5.7	5.3	5.0
16	22	7.0	6.7	6.6	6.1	5.7	5.4
18	25	7.3	7.0	7.2	6.7	6.4	6.1
19	27	7.9	7.6	7.4	7.3	7.0	6.9
19.5	27	8.0	7.7	7.6	7.4	7.2	7.0
22	30	9.2	8.6	8.3	8.0	7.7	7.3
24	32	9.9	9.6	9.3	9.2	8.6	7.9

(°C DB) : Dry Bulb Temperature (°C)

(°C WB) : Wet Bulb Temperature (°C)

HEATING CAPACITY (kW)

Outdoor temperature		Indoor temperature (°C DB)						
(°C WB)	(°C DB)	20	25	27	28	30	31	32
-16	-15	5.0	5.0	4.8	4.8	4.5	4.5	4.5
-11	-10	5.6	5.6	5.3	5.3	5.0	5.0	5.0
-6	-5	6.5	6.5	6.3	6.3	6.3	6.0	6.0
-1	0	7.5	7.5	7.1	7.1	6.8	6.8	6.8
6	7	8.3	8.3	8.3	8.3	8.3	8.3	8.0
9	10	8.6	8.4	8.4	8.4	8.4	8.4	8.3
14	15	8.8	8.6	8.6	8.6	8.6	8.6	8.4

(°C DB) : Dry Bulb Temperature (°C)

(°C WB) : Wet Bulb Temperature (°C)

30K

COOLING CAPACITY (kW)

Indoor temperature		Outdoor temperature (°CDB)					
(°C WB)	(°C DB)	20	25	32	35	40	45
14	20	7.7	7.6	7.0	6.9	6.3	6.2
16	22	8.4	8.1	7.9	7.4	6.9	6.7
18	25	8.8	8.4	8.6	8.1	7.7	7.6
19	27	9.5	9.2	9.0	8.8	8.4	8.4
19.5	27	9.7	9.3	9.2	9.0	8.6	8.5
22	30	11.1	10.4	10.0	9.7	9.3	9.1
24	32	12.0	11.6	11.3	11.1	10.4	9.9

(°C DB) : Dry Bulb Temperature (°C)

(°C WB) : Wet Bulb Temperature (°C)

5. CAPACITIES AND SELECTION DATA

HEATING CAPACITY (kW)

Outdoor temperature		Indoor temperature (°CDB)						
(°C WB)	(°C DB)	20	25	27	28	30	31	32
-16	-15	5.5	5.5	5.2	5.2	4.9	4.9	4.9
-11	-10	6.0	6.0	5.8	5.8	5.5	5.5	5.5
-6	-5	7.1	7.1	6.8	6.8	6.8	6.5	6.5
-1	0	8.1	8.1	7.7	7.7	7.4	7.4	7.4
6	7	9.0	8.8	8.8	8.8	8.7	8.7	8.7
9	10	9.3	9.1	9.1	9.1	9.1	9.1	9.0
14	15	9.6	9.3	9.3	9.3	9.3	9.3	9.1

(°C DB) : Dry Bulb Temperature (°C)

(°C WB) : Wet Bulb Temperature (°C)

36K

COOLING CAPACITY (kW)

Indoor temperature		Outdoor temperature (°C DB)					
(°C WB)	(°C DB)	20	25	32	35	40	45
14	20	10.2	10.0	9.8	9.5	9.0	8.5
16	22	10.6	10.5	10.0	10.0	9.4	8.8
18	25	11.0	10.8	10.6	10.2	9.8	9.1
19	27	11.5	11.2	10.8	10.5	10.0	9.5
19.5	27	11.6	11.4	11.0	10.7	10.2	9.9
22	30	11.8	11.6	11.0	10.9	10.6	10.2
24	32	12.0	11.8	11.4	11.2	10.8	10.6

(°C DB) : Dry Bulb Temperature (°C)

(°C WB) : Wet Bulb Temperature (°C)

HEATING CAPACITY (kW)

Outdoor temperature		Indoor temperature (°C DB)						
(°C WB)	(°C DB)	20	25	27	28	30	31	32
-16	-15	8.3	8.0	8.3	8.0	7.8	7.6	7.3
-11	-10	9.0	8.7	8.2	8.0	7.8	7.8	7.4
-6	-5	9.5	9.2	9.0	8.8	8.5	8.3	8.0
-1	0	10.7	10.4	10	9.7	9.5	9.3	9.0
6	7	11.5	11.2	10.9	10.6	10.5	10.2	10
9	10	12.0	11.6	11.4	10.9	10.8	10.7	10.6
14	15	12.6	12	11.8	11.5	11	10.6	10.4

(°C DB) : Dry Bulb Temperature (°C)

(°C WB) : Wet Bulb Temperature (°C)

5. CAPACITIES AND SELECTION DATA

42K

COOLING CAPACITY (kW)

Indoor temperature		Outdoor temperature (°CDB)					
(°C WB)	(°C DB)	20	25	32	35	40	45
14	20	11.1	10.7	10.0	9.6	8.9	8.6
16	22	12.1	11.4	11.4	10.7	9.6	9.3
18	25	12.5	12.1	12.1	11.4	11.1	10.7
19	27	13.6	13.2	12.9	12.5	12.1	11.8
19.5	27	13.9	13.2	13.2	12.9	12.1	12.1
22	30	15.7	15.0	14.3	13.9	13.2	12.5
24	32	17.1	16.4	16.1	15.7	15.0	13.6

(°C DB) : Dry Bulb Temperature (°C)

(°C WB) : Wet Bulb Temperature (°C)

HEATING CAPACITY (kW)

Outdoor temperature		Indoor temperature (°CDB)						
(°C WB)	(°C DB)	20	25	27	28	30	31	32
-16	-15	8.2	8.2	7.7	7.7	7.3	7.3	7.3
-11	-10	9.1	9.1	8.6	8.6	8.2	8.2	8.2
-6	-5	10.6	10.6	10.2	10.2	10.2	9.7	9.7
-1	0	12.2	12.2	11.5	11.5	11.1	11.1	11.1
6	7	13.5	13.5	13.5	13.5	13.5	13.5	13.1
9	10	13.9	13.7	13.7	13.7	13.7	13.7	13.5
14	15	14.4	13.9	13.9	13.9	13.9	13.9	13.7

(°C DB) : Dry Bulb Temperature (°C)

(°C WB) : Wet Bulb Temperature (°C)

48K

COOLING CAPACITY (kW)

Indoor temperature		Outdoor temperature (°C DB)					
(°C WB)	(°C DB)	20	25	32	35	40	45
14	20	12.7	12.4	11.5	11.2	10.4	9.8
16	22	13.8	13.2	13.0	12.1	11.2	10.7
18	25	14.4	13.8	14.1	13.2	12.7	12.1
19	27	15.6	15.0	14.7	14.4	13.8	13.5
19.5	27	15.8	15.3	15.0	14.7	14.1	13.8
22	30	18.1	17.0	16.4	15.8	15.3	14.4
24	32	19.6	19.0	18.4	18.1	17.0	15.6

(°C DB) : Dry Bulb Temperature (°C)

(°C WB) : Wet Bulb Temperature (°C)

5. CAPACITIES AND SELECTION DATA

HEATING CAPACITY (kW)

Outdoor temperature		Indoor temperature (°C DB)						
(°C WB)	(°C DB)	20	25	27	28	30	31	32
-16	-15	10.3	10.3	9.8	9.8	9.2	9.2	9.2
-11	-10	11.4	11.4	10.9	10.9	10.3	10.3	10.3
-6	-5	13.4	13.4	12.8	12.8	12.8	12.3	12.3
-1	0	15.3	15.3	14.5	14.5	13.9	13.9	13.9
6	7	17.0	17.0	17.0	17.0	17.0	17.0	16.4
9	10	17.6	17.3	17.3	17.3	17.3	17.3	17.0
14	15	18.1	17.6	17.6	17.6	17.6	17.6	17.3

(°C DB) : Dry Bulb Temperature (°C)

(°C WB) : Wet Bulb Temperature (°C)

60K

COOLING CAPACITY (kW)

Indoor temperature		Outdoor temperature (°C DB)					
(°C WB)	(°C DB)	20	25	32	35	40	45
14	20	15.1	14.8	13.8	13.4	12.4	11.7
16	22	16.5	15.8	15.5	14.4	13.4	12.7
18	25	17.2	16.5	16.9	15.8	15.1	14.4
19	27	18.6	17.9	17.5	17.2	16.5	16.2
19.5	27	18.9	18.2	17.9	17.5	16.9	16.5
22	30	21.7	20.3	19.6	18.9	18.2	17.2
24	32	23.4	22.7	22.0	21.7	20.3	18.6

(°C DB) : Dry Bulb Temperature (°C)

(°C WB) : Wet Bulb Temperature (°C)

HEATING CAPACITY (kW)

Outdoor temperature		Indoor temperature (°C DB)						
(°C WB)	(°C DB)	20	25	27	28	30	31	32
-16	-15	12.1	12.1	11.5	11.5	10.8	10.8	10.8
-11	-10	13.4	13.4	12.8	12.8	12.1	12.1	12.1
-6	-5	15.7	15.7	15.1	15.1	15.1	14.4	14.4
-1	0	18.0	18.0	17.0	17.0	16.4	16.4	16.4
6	7	20.0	20.0	20.0	20.0	20.0	20.0	19.3
9	10	20.7	20.3	20.3	20.3	20.3	20.3	20.0
14	15	21.3	20.7	20.7	20.7	20.7	20.7	20.3

(°C DB) : Dry Bulb Temperature (°C)

(°C WB) : Wet Bulb Temperature (°C)

5. CAPACITIES AND SELECTION DATA

Ceiling & Floor

18K

COOLING CAPACITY (kW)

Indoor temperature		Outdoor temperature (°CDB)					
(°C WB)	(°C DB)	20	25	32	35	40	45
14	20	4.65	4.54	4.22	4.12	3.80	3.59
16	22	5.07	4.86	4.75	4.44	4.12	3.91
18	25	5.28	5.07	5.17	4.86	4.65	4.44
19	27	5.70	5.49	5.39	5.28	5.07	4.96
19.5	27	5.81	5.60	5.49	5.39	5.17	5.07
22	30	6.65	6.23	6.02	5.81	5.60	5.28
24	32	7.18	6.97	6.76	6.65	6.23	5.70

(°C DB) : Dry Bulb Temperature (°C)

(°C WB) : Wet Bulb Temperature (°C)

HEATING CAPACITY (kW)

Outdoor temperature		Indoor temperature (°CDB)						
(°C WB)	(°C DB)	20	25	27	28	30	31	32
-16	-15	3.40	3.40	3.21	3.21	3.03	3.03	3.03
-11	-10	3.76	3.76	3.58	3.58	3.40	3.40	3.40
-6	-5	4.41	4.41	4.22	4.22	4.22	4.04	4.04
-1	0	5.05	5.05	4.77	4.77	4.59	4.59	4.59
6	7	5.60	5.60	5.60	5.60	5.60	5.60	5.42
9	10	5.78	5.69	5.69	5.69	5.69	5.69	5.60
14	15	5.97	5.78	5.78	5.78	5.78	5.78	5.69

(°C DB) : Dry Bulb Temperature (°C)

(°C WB) : Wet Bulb Temperature (°C)

24K

COOLING CAPACITY (kW)

Indoor temperature		Outdoor temperature (°C DB)					
(°C WB)	(°C DB)	20	25	32	35	40	45
14	20	6.1	5.9	5.5	5.4	5.0	4.7
16	22	6.6	6.3	6.2	5.8	5.4	5.1
18	25	6.9	6.6	6.8	6.3	6.1	5.8
19	27	7.5	7.2	7.0	6.9	6.6	6.5
19.5	27	7.6	7.3	7.2	7.0	6.8	6.6
22	30	8.7	8.1	7.9	7.6	7.3	6.9
24	32	9.4	9.1	8.8	8.7	8.1	7.5

(°C DB) : Dry Bulb Temperature (°C)

(°C WB) : Wet Bulb Temperature (°C)

5. CAPACITIES AND SELECTION DATA

HEATING CAPACITY (kW)

Outdoor temperature		Indoor temperature (°C DB)						
(°C WB)	(°C DB)	20	25	27	28	30	31	32
-16	-15	4.7	4.7	4.5	4.5	4.2	4.2	4.2
-11	-10	5.2	5.2	5.0	5.0	4.7	4.7	4.7
-6	-5	6.1	6.1	5.9	5.9	5.9	5.6	5.6
-1	0	7.0	7.0	6.6	6.6	6.4	6.4	6.4
6	7	7.8	7.8	7.8	7.8	7.8	7.8	7.5
9	10	8.1	7.9	7.9	7.9	7.9	7.9	7.8
14	15	8.3	8.1	8.1	8.1	8.1	8.1	7.9

(°C DB) : Dry Bulb Temperature (°C)

(°C WB) : Wet Bulb Temperature (°C)

30K

COOLING CAPACITY (kW)

Indoor temperature		Outdoor temperature (°CDB)					
(°C WB)	(°C DB)	20	25	32	35	40	45
14	20	7.7	7.6	7.0	6.9	6.3	6.2
16	22	8.4	8.1	7.9	7.4	6.9	6.7
18	25	8.8	8.4	8.6	8.1	7.7	7.6
19	27	9.5	9.2	9.0	8.8	8.4	8.4
19.5	27	9.7	9.3	9.2	9.0	8.6	8.5
22	30	11.1	10.4	10.0	9.7	9.3	9.1
24	32	12.0	11.6	11.3	11.1	10.4	9.9

(°C DB) : Dry Bulb Temperature (°C)

(°C WB) : Wet Bulb Temperature (°C)

HEATING CAPACITY (kW)

Outdoor temperature		Indoor temperature (°CDB)						
(°C WB)	(°C DB)	20	25	27	28	30	31	32
-16	-15	5.5	5.5	5.2	5.2	4.9	4.9	4.9
-11	-10	6.0	6.0	5.8	5.8	5.5	5.5	5.5
-6	-5	7.1	7.1	6.8	6.8	6.8	6.5	6.5
-1	0	8.1	8.1	7.7	7.7	7.4	7.4	7.4
6	7	9.0	8.8	8.8	8.8	8.7	8.7	8.7
9	10	9.3	9.1	9.1	9.1	9.1	9.1	9.0
14	15	9.6	9.3	9.3	9.3	9.3	9.3	9.1

(°C DB) : Dry Bulb Temperature (°C)

(°C WB) : Wet Bulb Temperature (°C)

5. CAPACITIES AND SELECTION DATA

36K

COOLING CAPACITY (kW)

Indoor temperature		Outdoor temperature (°C DB)					
(°C WB)	(°C DB)	20	25	32	35	40	45
14	20	10.2	10	9.8	9.5	9	8.5
16	22	10.6	10.5	10	10	9.4	8.8
18	25	11	10.8	10.6	10.2	9.8	9.1
19	27	11.5	11.2	10.5	10	9.9	9.5
19.5	27	11.6	11.4	11	10.7	10.2	9.9
22	30	11.8	11.6	11.2	10.9	10.6	10.2
24	32	12	11.8	11.4	11.2	10.8	10.6

(°C DB) : Dry Bulb Temperature (°C)

(°C WB) : Wet Bulb Temperature (°C)

HEATING CAPACITY (kW)

Outdoor temperature		Indoor temperature (°C DB)						
(°C WB)	(°C DB)	20	25	27	28	30	31	32
-16	-15	8.3	8.0	8.3	8.0	7.8	7.6	7.3
-11	-10	9.0	8.7	8.2	8.0	7.8	7.8	7.4
-6	-5	9.5	9.2	9.0	8.8	8.5	8.3	8.0
-1	0	10.7	10.4	10	9.7	9.5	9.3	9.0
6	7	11.3	11.2	10.9	10.6	10.5	10.2	10
9	10	12.0	11.6	11.4	10.9	10.8	10.7	10.6
14	15	12.6	12	11.8	11.5	11	10.6	10.4

(°C DB) : Dry Bulb Temperature (°C)

(°C WB) : Wet Bulb Temperature (°C)

42K

COOLING CAPACITY (kW)

Indoor temperature		Outdoor temperature (°CDB)					
(°C WB)	(°C DB)	20	25	32	35	40	45
14	20	10.9	10.5	9.8	9.5	8.8	8.4
16	22	11.9	11.2	11.2	10.5	9.5	9.1
18	25	12.3	11.9	11.9	11.2	10.9	10.5
19	27	13.4	13.0	12.7	12.3	11.9	11.6
19.5	27	13.7	13.0	13.0	12.7	11.9	11.9
22	30	15.5	14.8	14.1	13.7	13.0	12.3
24	32	16.9	16.2	15.8	15.5	14.8	13.4

(°C DB) : Dry Bulb Temperature (°C)

(°C WB) : Wet Bulb Temperature (°C)

5. CAPACITIES AND SELECTION DATA

HEATING CAPACITY (kW)

Outdoor temperature		Indoor temperature (°CDB)						
(°C WB)	(°C DB)	20	25	27	28	30	31	32
-16	-15	8.2	8.2	7.7	7.7	7.3	7.3	7.3
-11	-10	9.1	9.1	8.6	8.6	8.2	8.2	8.2
-6	-5	10.6	10.6	10.2	10.2	10.2	9.7	9.7
-1	0	12.2	12.2	11.5	11.5	11.1	11.1	11.1
6	7	13.5	13.5	13.5	13.5	13.5	13.5	13.1
9	10	13.9	13.7	13.7	13.7	13.7	13.7	13.5
14	15	14.4	13.9	13.9	13.9	13.9	13.9	13.7

(°C DB) : Dry Bulb Temperature (°C)

(°C WB) : Wet Bulb Temperature (°C)

48K

COOLING CAPACITY (kW)

Indoor temperature		Outdoor temperature (°C DB)					
(°C WB)	(°C DB)	20	25	32	35	40	45
14	20	12.6	12.3	11.4	11.2	10.3	9.7
16	22	13.7	13.2	12.9	12.0	11.2	10.6
18	25	14.3	13.7	14.0	13.2	12.6	12.0
19	27	15.4	14.9	14.6	14.3	13.7	13.4
19.5	27	15.7	15.2	14.9	14.6	14.0	13.7
22	30	18.0	16.9	16.3	15.7	15.2	14.3
24	32	19.4	18.9	18.3	18.0	16.9	15.4

(°C DB) : Dry Bulb Temperature (°C)

(°C WB) : Wet Bulb Temperature (°C)

5. CAPACITIES AND SELECTION DATA

HEATING CAPACITY (kW)

Outdoor temperature		Indoor temperature (°C DB)						
(°C WB)	(°C DB)	20	25	27	28	30	31	32
-16	-15	10.1	10.1	9.6	9.6	9.0	9.0	9.0
-11	-10	11.2	11.2	10.7	10.7	10.1	10.1	10.1
-6	-5	13.1	13.1	12.6	12.6	12.6	12.0	12.0
-1	0	15.1	15.1	14.2	14.2	13.7	13.7	13.7
6	7	16.7	16.7	16.7	16.7	16.7	16.7	16.2
9	10	17.2	17.0	17.0	17.0	17.0	17.0	16.7
14	15	17.8	17.2	17.2	17.2	17.2	17.2	17.0

(°C DB) : Dry Bulb Temperature (°C)

(°C WB) : Wet Bulb Temperature (°C)

60K

COOLING CAPACITY (kW)

Indoor temperature		Outdoor temperature (°C DB)					
(°C WB)	(°C DB)	20	25	32	35	40	45
14	20	15.0	14.6	13.6	13.3	12.2	11.6
16	22	16.3	15.6	15.3	14.3	13.3	12.6
18	25	17.0	16.3	16.7	15.6	15.0	14.3
19	27	18.4	17.7	17.3	17.0	16.3	16.0
19.5	27	18.7	18.0	17.7	17.3	16.7	16.3
22	30	21.4	20.1	19.4	18.7	18.0	17.0
24	32	23.1	22.4	21.8	21.4	20.1	18.4

(°C DB) : Dry Bulb Temperature (°C)

(°C WB) : Wet Bulb Temperature (°C)

HEATING CAPACITY (kW)

Outdoor temperature		Indoor temperature (°C DB)						
(°C WB)	(°C DB)	20	25	27	28	30	31	32
-16	-15	10.9	10.9	10.3	10.3	9.7	9.7	9.7
-11	-10	12.1	12.1	11.5	11.5	10.9	10.9	10.9
-6	-5	14.2	14.2	13.6	13.6	13.6	13.0	13.0
-1	0	16.2	16.2	15.3	15.3	14.8	14.8	14.8
6	7	18.0	18.0	18.0	18.0	18.0	18.0	17.4
9	10	18.6	18.3	18.3	18.3	18.3	18.3	18.0
14	15	19.2	18.6	18.6	18.6	18.6	18.6	18.3

(°C DB) : Dry Bulb Temperature (°C)

(°C WB) : Wet Bulb Temperature (°C)

5. CAPACITIES AND SELECTION DATA

Console

9K

COOLING CAPACITY (kW)

Indoor temperature		Outdoor temperature (°C DB)					
(°C WB)	(°C DB)	20	25	32	35	40	45
14	20	2.60	2.54	2.36	2.30	2.12	2.01
16	22	2.83	2.71	2.66	2.48	2.30	2.18
18	25	2.95	2.83	2.89	2.71	2.60	2.48
19	27	3.19	3.07	3.01	2.95	2.83	2.77
19.5	27	3.25	3.13	3.07	3.01	2.89	2.83
22	30	3.72	3.48	3.36	3.25	3.13	2.95
24	32	4.01	3.89	3.78	3.72	3.48	3.19

(°C DB) : Dry Bulb Temperature (°C)

(°C WB) : Wet Bulb Temperature (°C)

HEATING CAPACITY (kW)

Outdoor temperature		Indoor temperature (°C DB)						
(°C WB)	(°C DB)	20	25	27	28	30	31	32
-16	-15	1.85	1.85	1.75	1.75	1.65	1.65	1.65
-11	-10	2.05	2.05	1.95	1.95	1.85	1.85	1.85
-6	-5	2.40	2.40	2.30	2.30	2.30	2.20	2.20
-1	0	2.75	2.75	2.60	2.60	2.50	2.50	2.50
6	7	3.05	3.05	3.05	3.05	3.05	3.05	2.95
9	10	3.15	3.10	3.10	3.10	3.10	3.10	3.05
14	15	3.25	3.15	3.15	3.15	3.15	3.15	3.10

(°C DB) : Dry Bulb Temperature (°C)

(°C WB) : Wet Bulb Temperature (°C)

12K

COOLING CAPACITY (kW)

Indoor temperature		Outdoor temperature (°C DB)					
(°C WB)	(°C DB)	20	25	32	35	40	45
14	20	3.1	3.0	2.8	2.7	2.5	2.4
16	22	3.4	3.2	3.2	3.0	2.7	2.6
18	25	3.5	3.4	3.4	3.2	3.1	3.0
19	27	3.8	3.7	3.6	3.5	3.4	3.3
19.5	27	3.9	3.7	3.7	3.6	3.4	3.4
22	30	4.4	4.2	4.0	3.9	3.7	3.5
24	32	4.8	4.6	4.5	4.4	4.2	3.8

(°C DB) : Dry Bulb Temperature (°C)

(°C WB) : Wet Bulb Temperature (°C)

5. CAPACITIES AND SELECTION DATA

HEATING CAPACITY (kW)

Outdoor temperature		Indoor temperature (°C DB)						
(°C WB)	(°C DB)	20	25	27	28	30	31	32
-16	-15	2.3	2.3	2.2	2.2	2.1	2.1	2.1
-11	-10	2.6	2.6	2.4	2.4	2.3	2.3	2.3
-6	-5	3.0	3.0	2.9	2.9	2.9	2.7	2.7
-1	0	3.4	3.4	3.2	3.2	3.1	3.1	3.1
6	7	3.8	3.8	3.8	3.8	3.8	3.8	3.7
9	10	3.9	3.9	3.9	3.9	3.9	3.9	3.8
14	15	4.0	3.9	3.9	3.9	3.9	3.9	3.9

(°C DB) : Dry Bulb Temperature (°C)

(°C WB) : Wet Bulb Temperature (°C)

18K

COOLING CAPACITY (kW)

Indoor temperature		Outdoor temperature (°CDB)					
(°C WB)	(°C DB)	20	25	32	35	40	45
14	20	4.40	4.30	4.00	3.90	3.60	3.40
16	22	4.80	4.60	4.50	4.20	3.90	3.70
18	25	5.00	4.80	4.90	4.60	4.40	4.20
19	27	5.40	5.20	5.10	5.00	4.80	4.70
19.5	27	5.50	5.30	5.20	5.10	4.90	4.80
22	30	6.30	5.90	5.70	5.50	5.30	5.00
24	32	6.80	6.60	6.40	6.30	5.90	5.40

(°C DB) : Dry Bulb Temperature (°C)

(°C WB) : Wet Bulb Temperature (°C)

HEATING CAPACITY (kW)

Outdoor temperature		Indoor temperature (°CDB)						
(°C WB)	(°C DB)	20	25	27	28	30	31	32
-16	-15	3.09	3.09	2.93	2.93	2.76	2.76	2.76
-11	-10	3.43	3.43	3.26	3.26	3.09	3.09	3.09
-6	-5	4.01	4.01	3.85	3.85	3.85	3.68	3.68
-1	0	4.60	4.60	4.35	4.35	4.18	4.18	4.18
6	7	5.10	5.10	5.10	5.10	5.10	5.10	4.93
9	10	5.27	5.18	5.18	5.18	5.18	5.18	5.10
14	15	5.43	5.27	5.27	5.27	5.27	5.27	5.18

(°C DB) : Dry Bulb Temperature (°C)

(°C WB) : Wet Bulb Temperature (°C)

5. CAPACITIES AND SELECTION DATA

5.2 Piping length correction factor

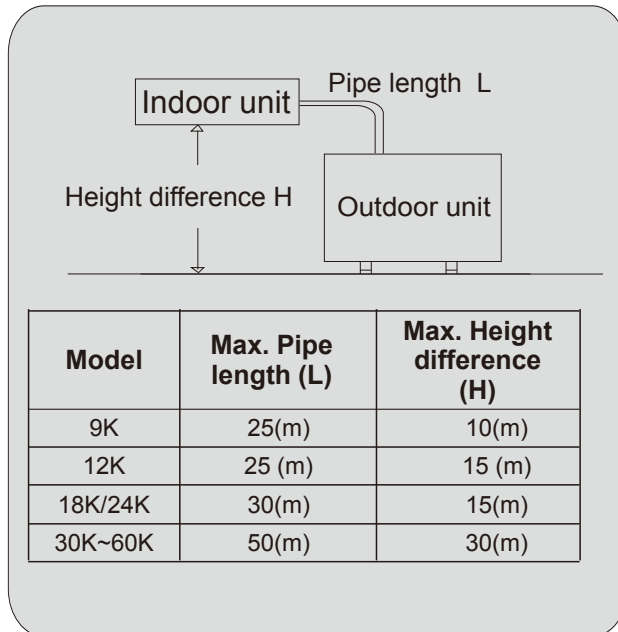

The correction factor is based on the equivalent piping length in meters (EL) and the height between outdoor and indoor units in meters (H).

H:

Height between indoor unit and outdoor unit (m).

- H>0: Position of outdoor unit is higher than position of indoor unit (m).
- H<0: Position of outdoor unit is lower than position of indoor unit (m).

L:

Actual one-way piping length between indoor unit and outdoor unit (m).

EL:

Equivalent one-way piping length between indoor unit and outdoor unit (m).

Gas Diameter (mm/inch)	9.52 (3/8')	12.7 (1/2')	15.88 (5/8')	19.05 (3/4')
90° Elbow	0.15	0.2	0.25	0.35

Cooling

EL Model	5m	10m	15m	20m	25m	30m	35m	40m	45m	50m
9K	1.0	0.96	0.92	0.88	0.84	--	--	--	--	--
12K	1.0	0.98	0.96	0.95	0.94	--	--	--	--	--
18K	1.0	0.97	0.94	0.92	0.89	0.86	--	--	--	--
24K	1.0	0.99	0.98	0.97	0.97	0.96	--	--	--	--
30K	1.0	0.94	0.92	0.90	0.88	0.84	0.82	0.80	0.77	0.73
36K	1.0	0.95	0.93	0.90	0.88	0.85	0.83	0.80	0.78	0.75
42K	1.0	0.95	0.92	0.88	0.87	0.85	0.83	0.80	0.78	0.75
48K/60K	1.0	0.98	0.96	0.94	0.92	0.89	0.86	0.83	0.79	0.75

5. CAPACITIES AND SELECTION DATA

Heating

EL Model	5m	10m	15m	20m	25m	30m	35m	40m	45m	50m
9K	1.0	0.97	0.94	0.92	0.89					
12K	1.0	0.99	0.97	0.95	0.94					
18K	1.0	0.99	0.98	0.97	0.96	0.95	--	--	--	--
24K	1.0	0.98	0.97	0.97	0.96	0.95	--	--	--	--
30K	1.0	0.93	0.90	0.88	0.84	0.82	0.78	0.75	0.72	0.69
36K/42K	1.0	0.94	0.91	0.88	0.85	0.82	0.79	0.76	0.73	0.70
48K/60K	1.0	0.99	0.98	0.97	0.95	0.93	0.90	0.87	0.84	0.80

The correction factor of height between indoor unit and outdoor unit

Height difference	5m	10m	30m
Factor	0.01	0.02	0.025

To ensure correct unit selection, consider the farthest indoor unit.

NOTE:

1. Above data is assuming that the height difference between indoor unit and outdoor unit is 0m.
2. Be sure to minimize length of connection pipes to optimize performance. If the outdoor unit is installed higher or lower than the indoor unit, it is necessary to apply height correction factor additionally to length correction factor to calculate cooling/heating.
If outdoor unit is higher, correction should be applied to cooling capacity, if outdoor unit is lower, correction should be applied to heating capacity.

5. CAPACITIES AND SELECTION DATA

5.3 Correction factors according to defrosting operation

The heating capacity in the preceding paragraph, excludes the condition of the frost or the defrosting operation period. In consideration of the frost or the defrosting operation, the heating capacity is corrected by the equation below.

Corrected heating capacity = Defrost Correction factor x unit capacity

OUTDOOR TEMPERATURE (°CDB)	-15	-10	-5	0	7	10	15
Correction factor (humidity rate 85% RH)	0.95	0.95	0.91	0.81	1.0	1.0	1.0

Correction Factor

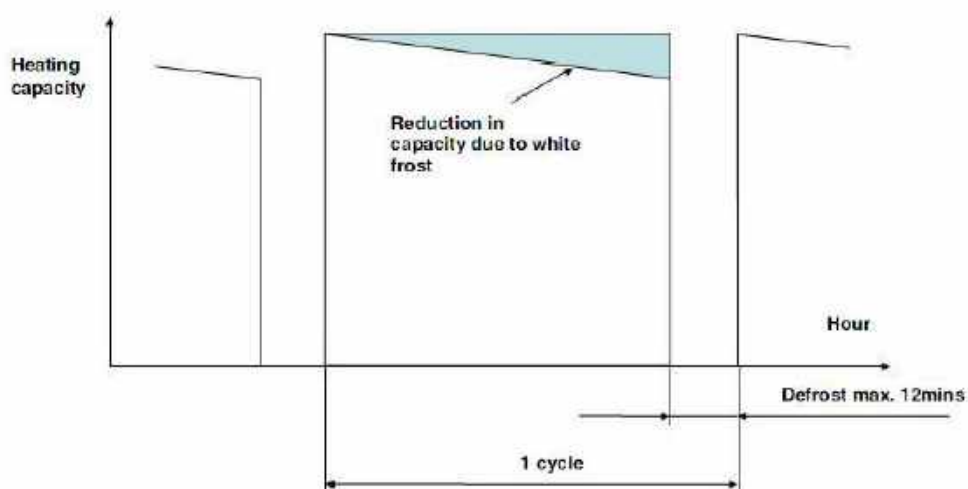

NOTE:

The correction factor is not valid for special conditions such as snowfall or operation in a transitional period.

6. SOUND PRESSURE DATA

6. Sound pressure data

Indoor unit

Duct

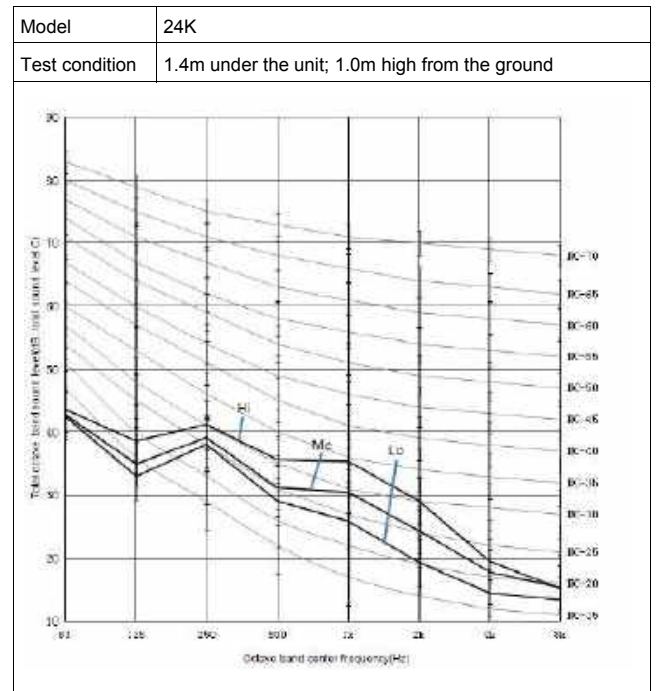
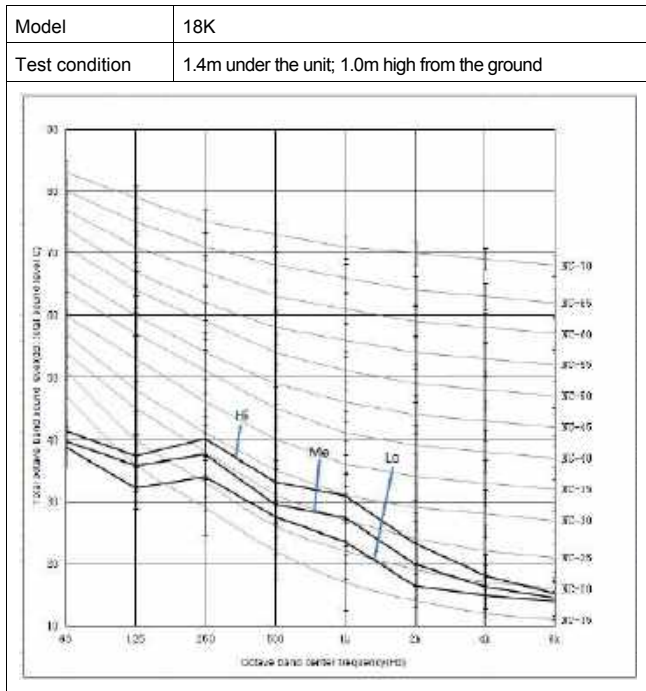
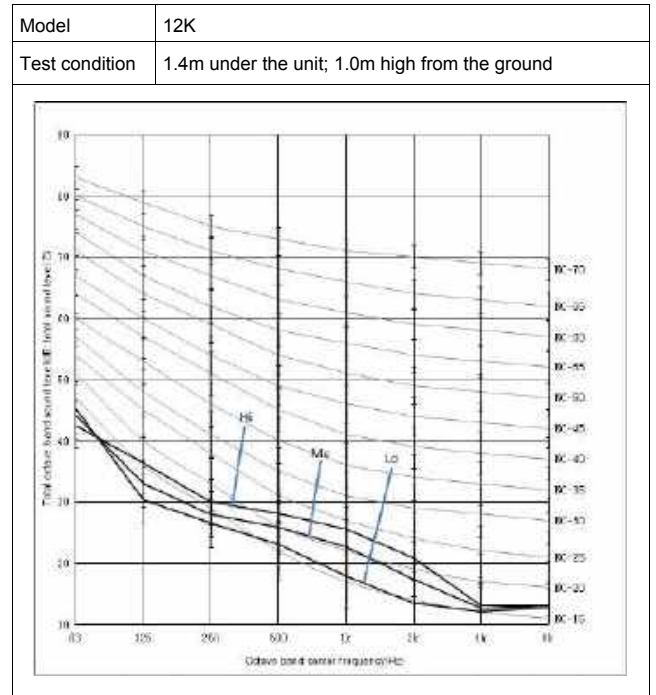
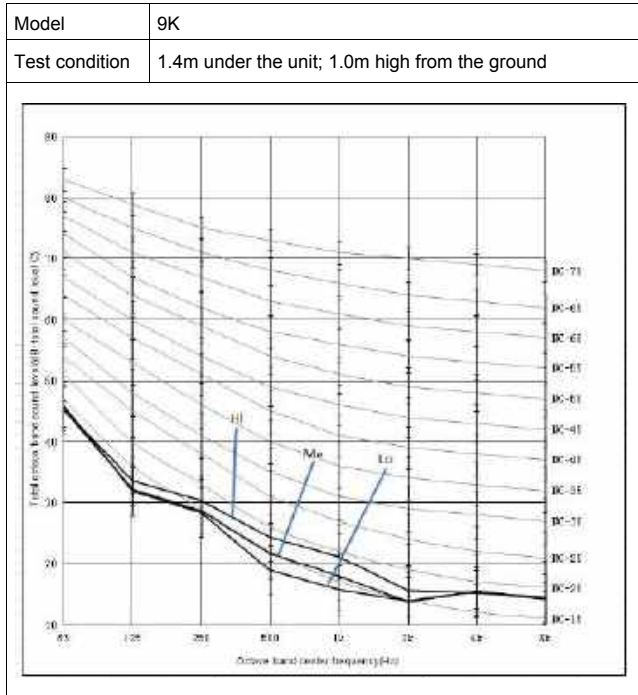

6. SOUND PRESSURE DATA

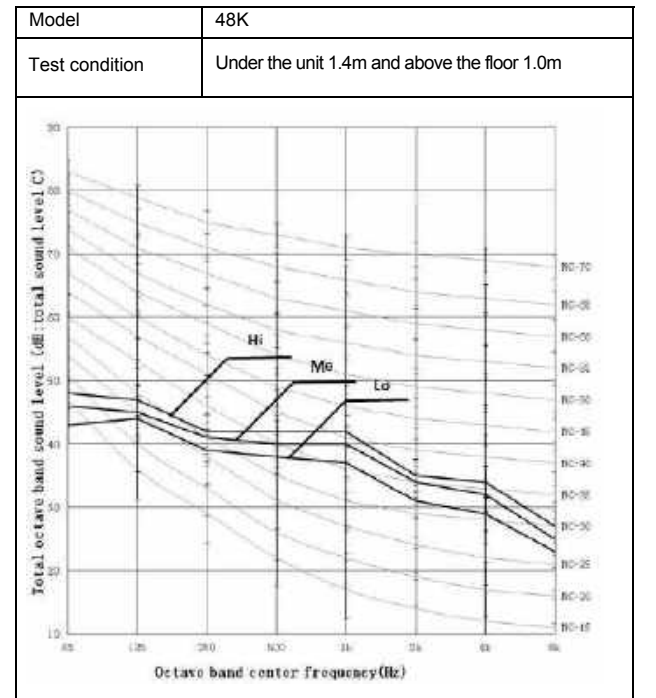
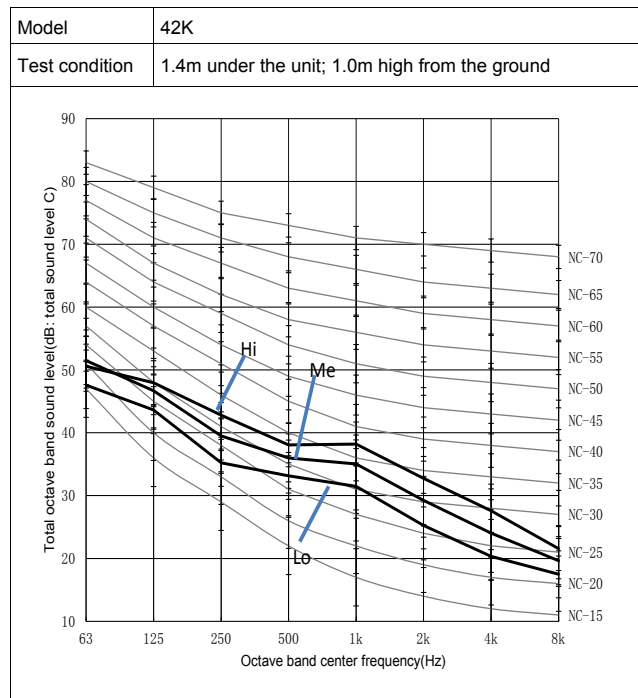
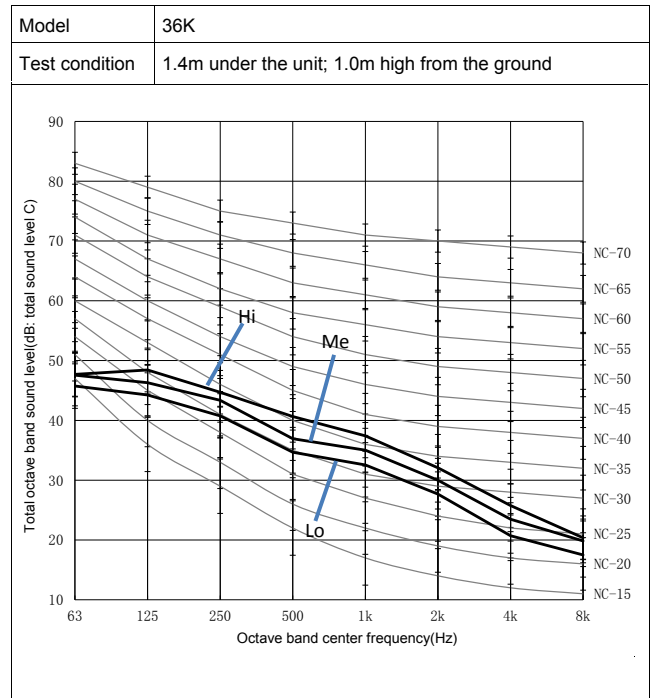
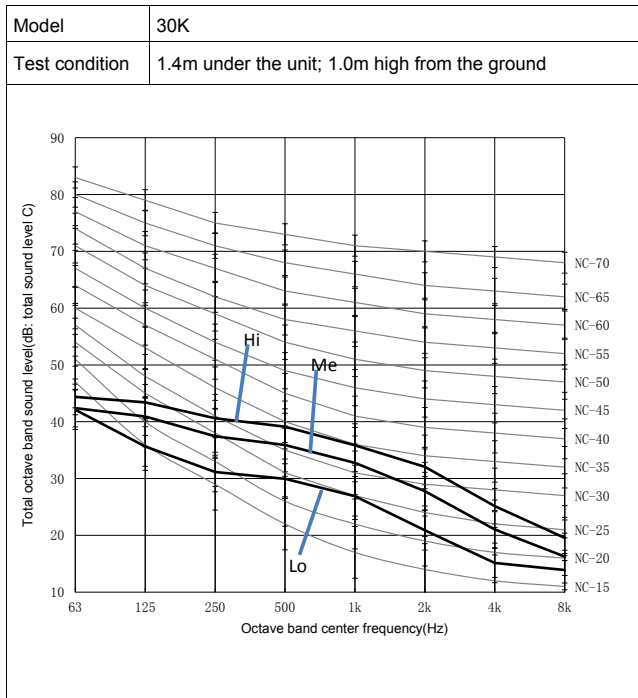

6. SOUND PRESSURE DATA

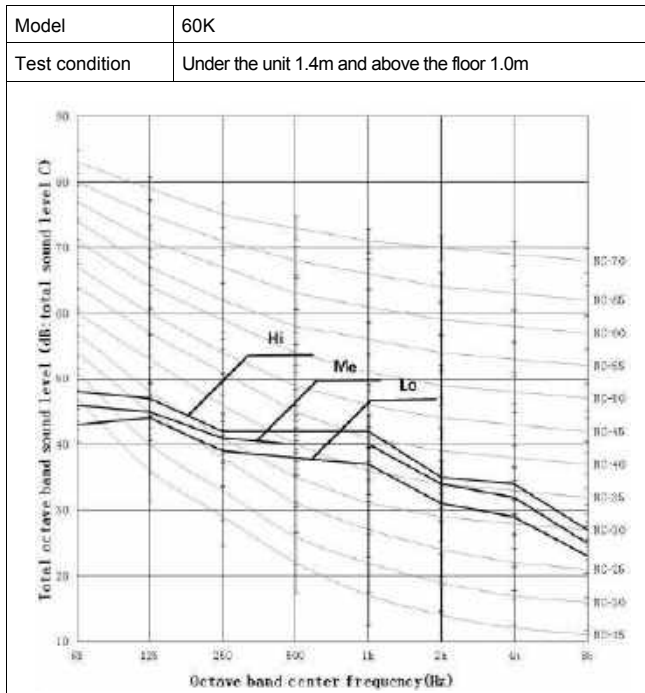

Cassette

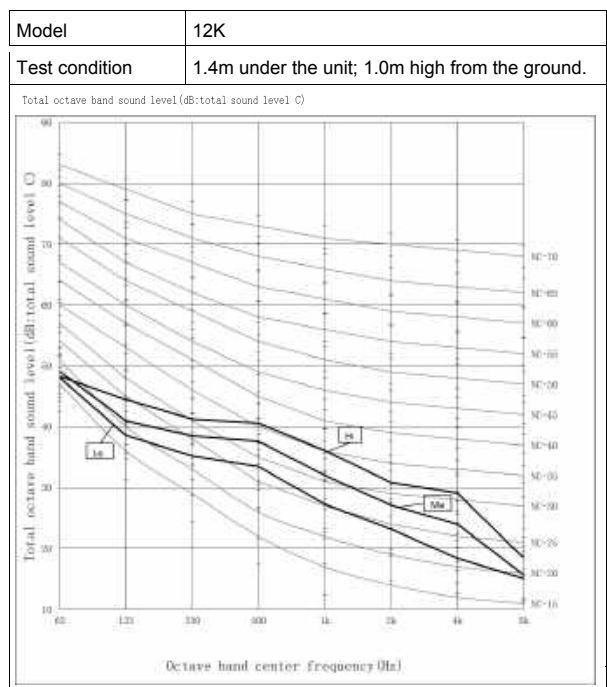
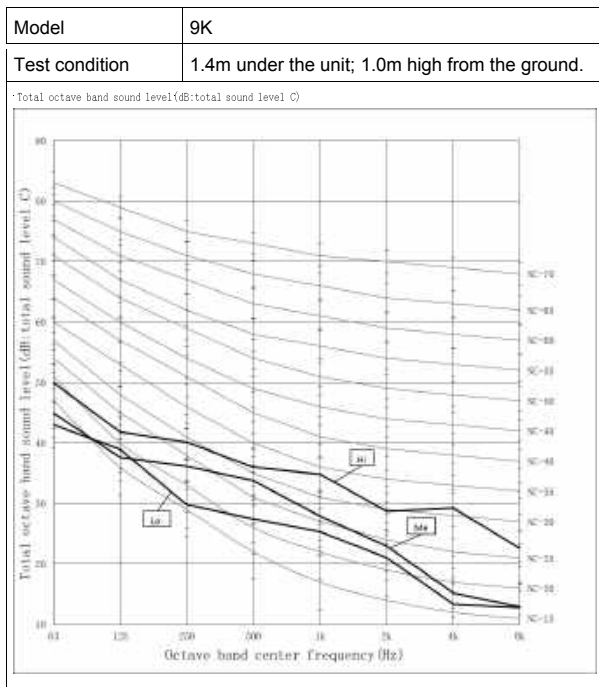

6. SOUND PRESSURE DATA

Model	18K
Test condition	1.4m under the unit; 1.0m high from the ground.

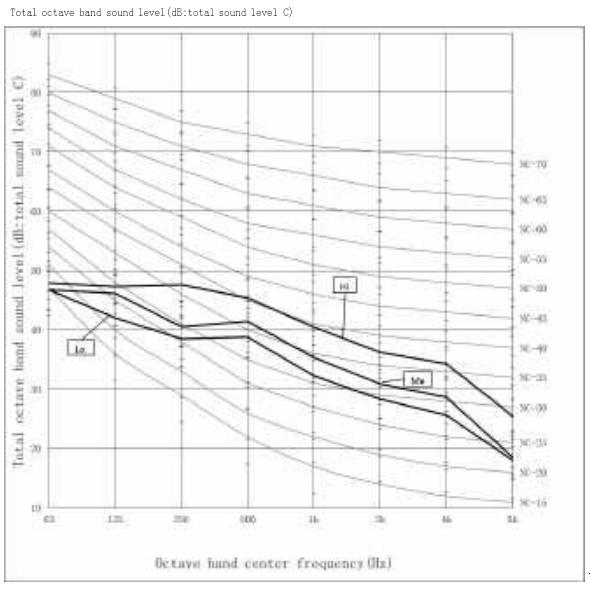

Model	24K
Test condition	1.4m under the unit; 1.0m high from the ground.

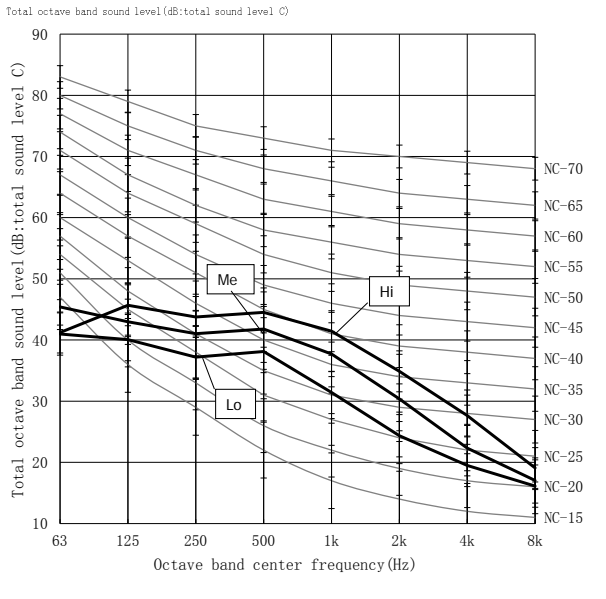

Model	30K
Test condition	1.4m under the unit; 1.0m high from the ground.

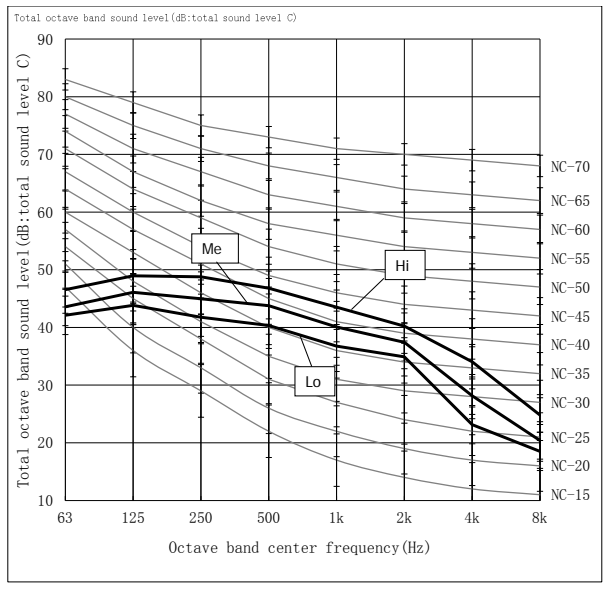

Model	36K
Test condition	1.4m under the unit; 1.0m high from the ground.

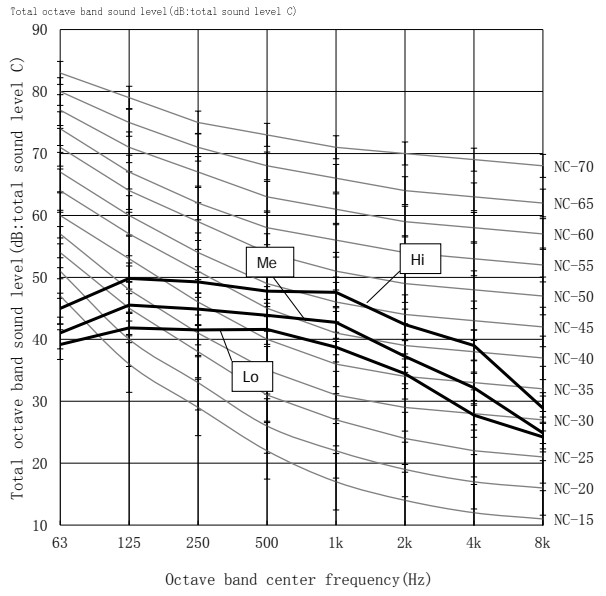

6. SOUND PRESSURE DATA

Model	42K
Test condition	1.4m under the unit; 1.0m high from the ground.

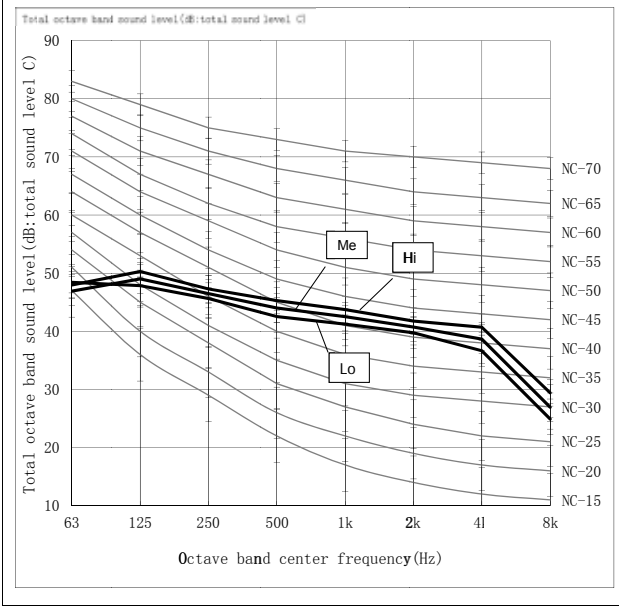

Model	48K
Test condition	1.4m under the unit; 1.0m high from the ground.

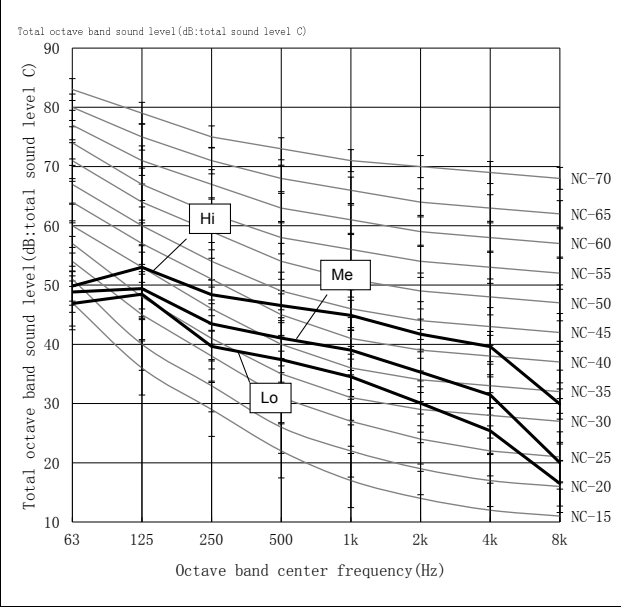

Model	60K
Test condition	1.4m under the unit; 1.0m high from the ground.

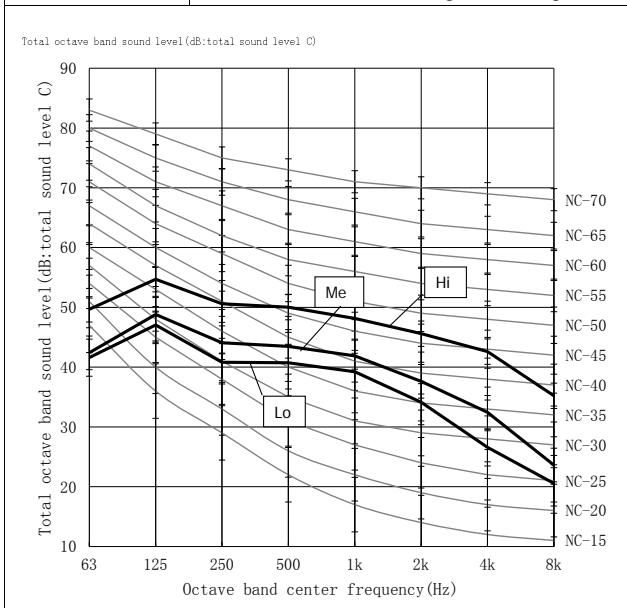

6. SOUND PRESSURE DATA

Ceiling & Floor

Model	18K
Test condition	1.0m ahead of the unit; 1.0m under the unit; 1.0m high from the ground.

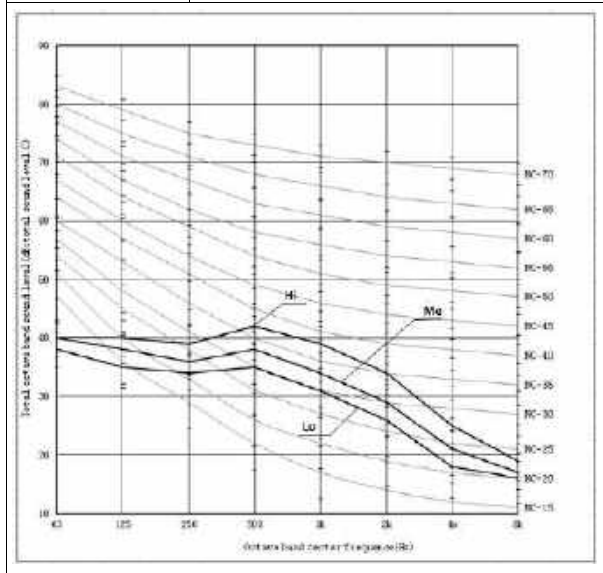

Model	24K
Test condition	1.0m ahead of the unit; 1.0m under the unit; 1.0m high from the ground.

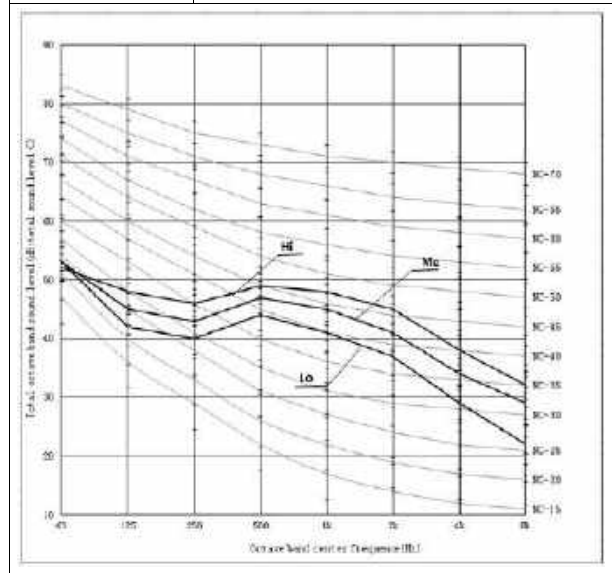

Model	30K
Test condition	1.0m ahead of the unit; 1.0m under the unit; 1.0m high from the ground.

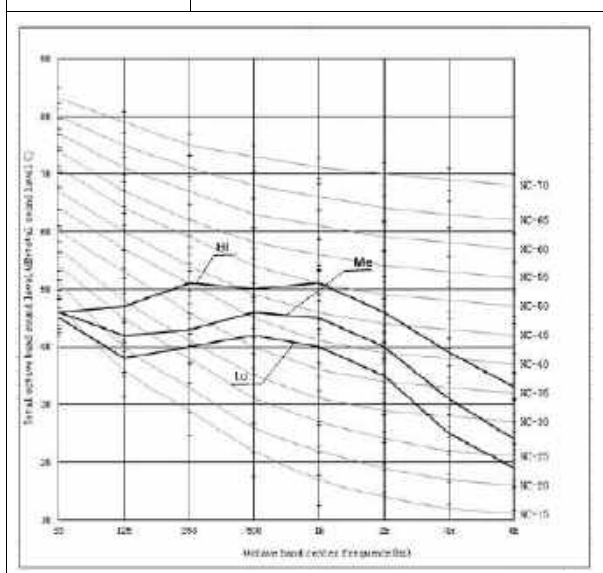

Model	36K
Test condition	1.0m ahead of the unit; 1.0m under the unit; 1.0m high from the ground.

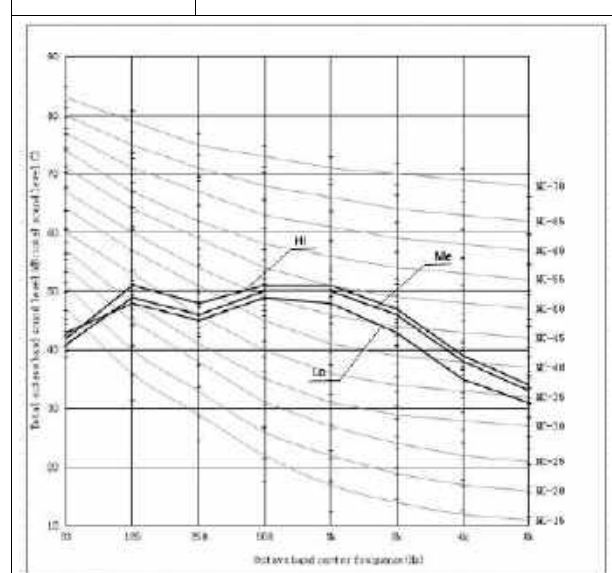

6. SOUND PRESSURE DATA

Model	42K
Test condition	1.0m ahead of the unit; 1.0m under the unit; 1.0m high from the ground.

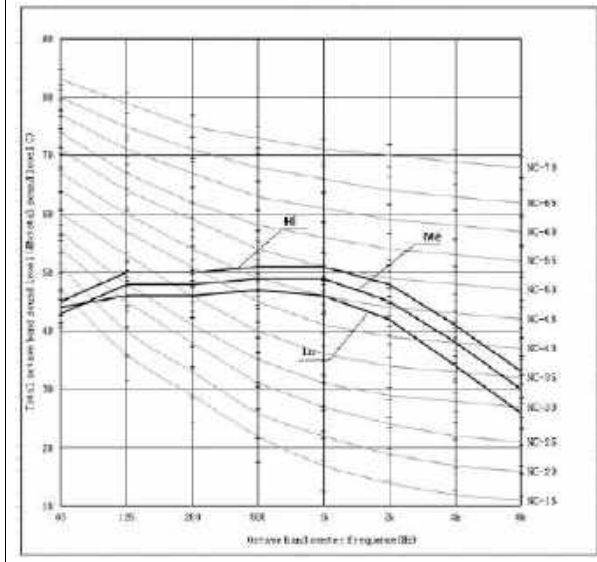

Model	48K
Test condition	1.0m ahead of the unit; 1.0m under the unit; 1.0m high from the ground.

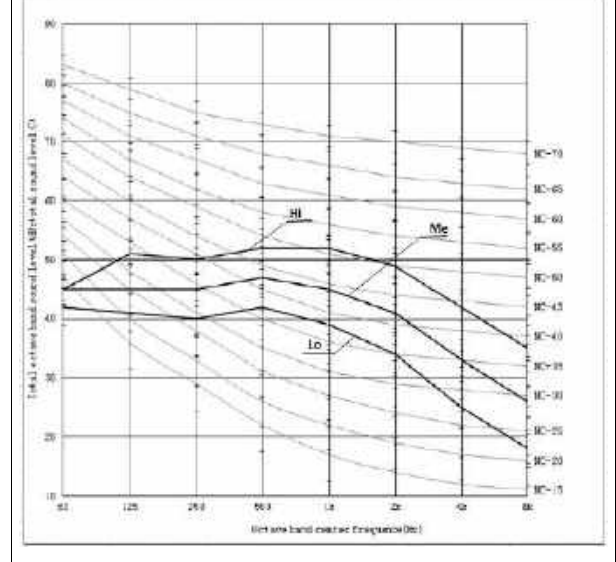

Model	60K
Test condition	1.0m ahead of the unit; 1.0m under the unit; 1.0m high from the ground.

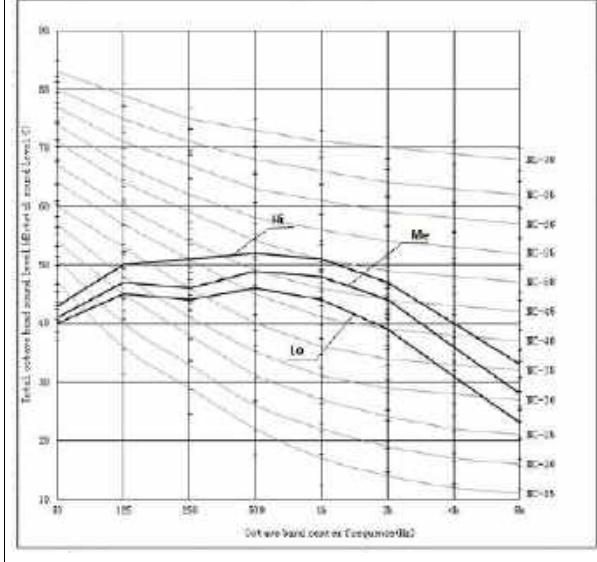

6. SOUND PRESSURE DATA

Console

Model	9K
Test condition	1.0m ahead of the unit; 1.0m high from the unit.

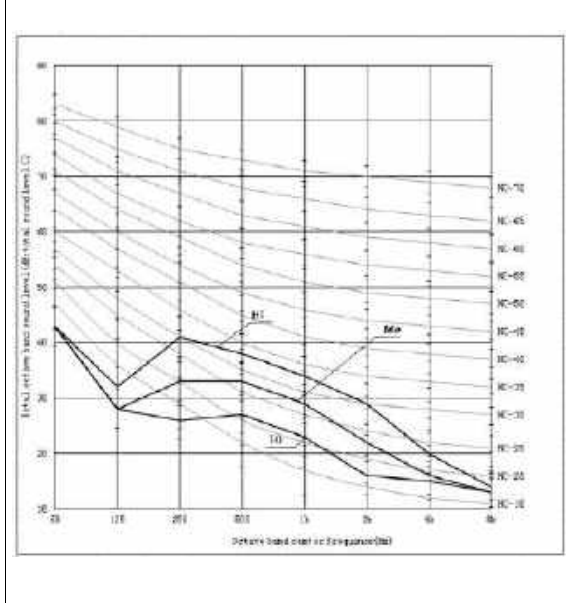

Model	12K
Test condition	1.0m ahead of the unit; 1.0m high from the unit.

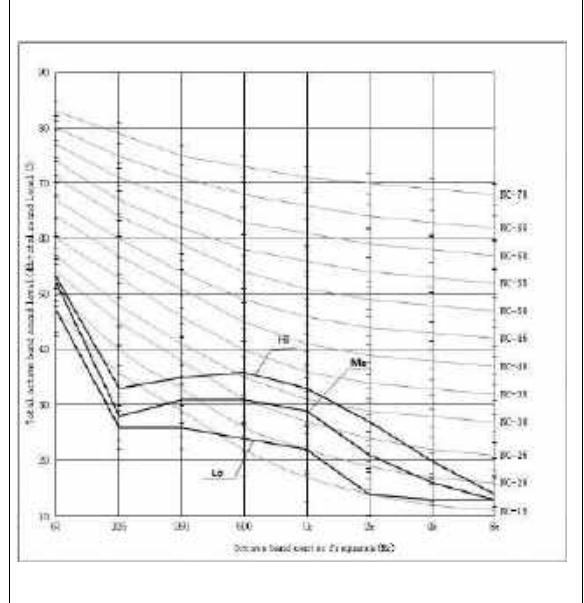

Model	18K
Test condition	1.0m ahead of the unit; 1.0m high from the unit.

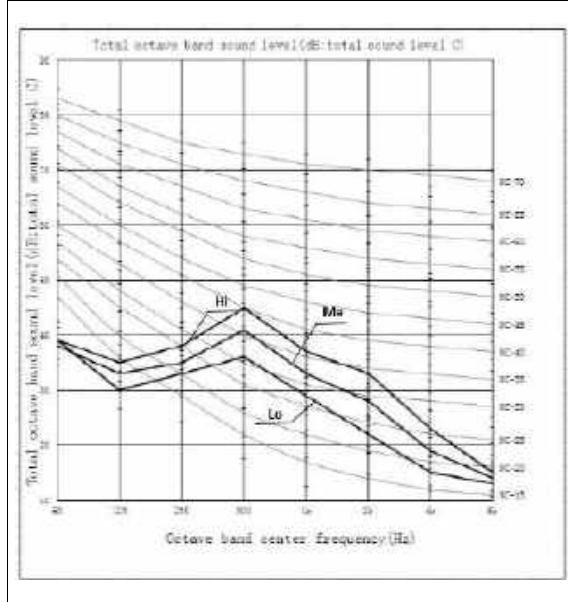

6. SOUND PRESSURE DATA

Outdoor unit

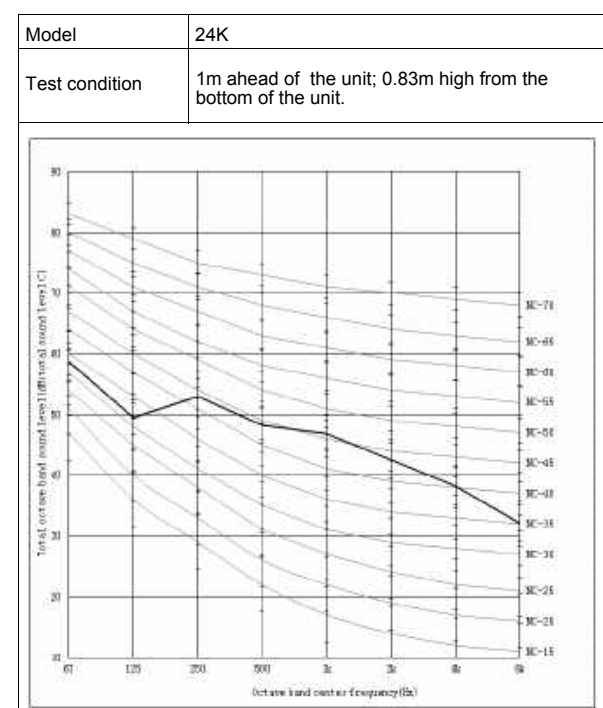
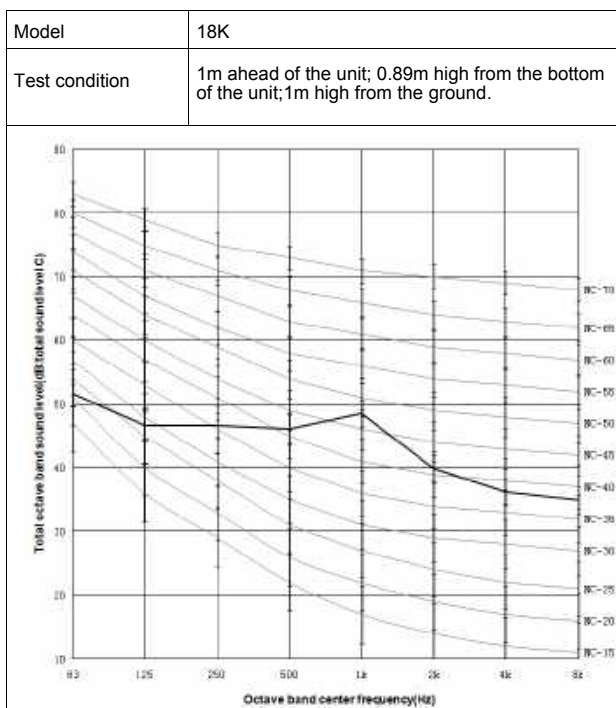
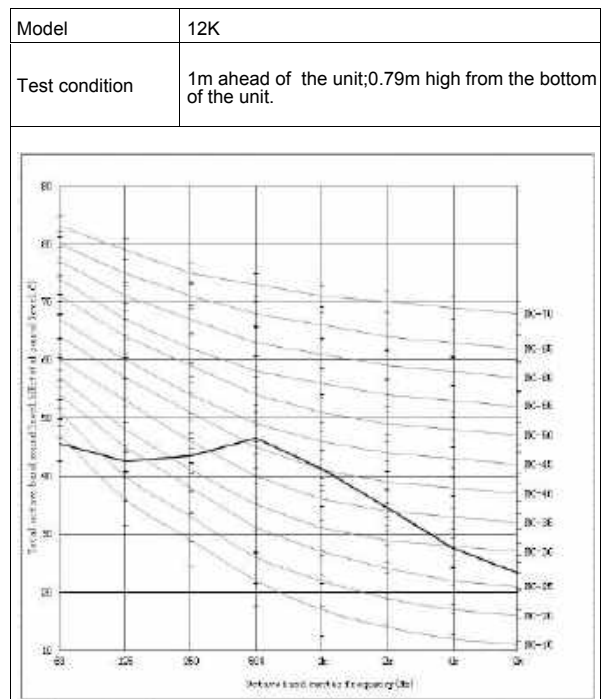
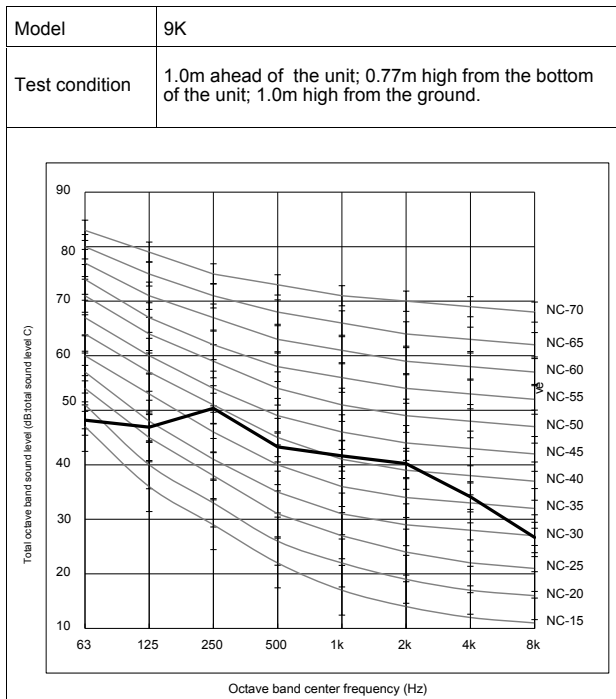

6. SOUND PRESSURE DATA

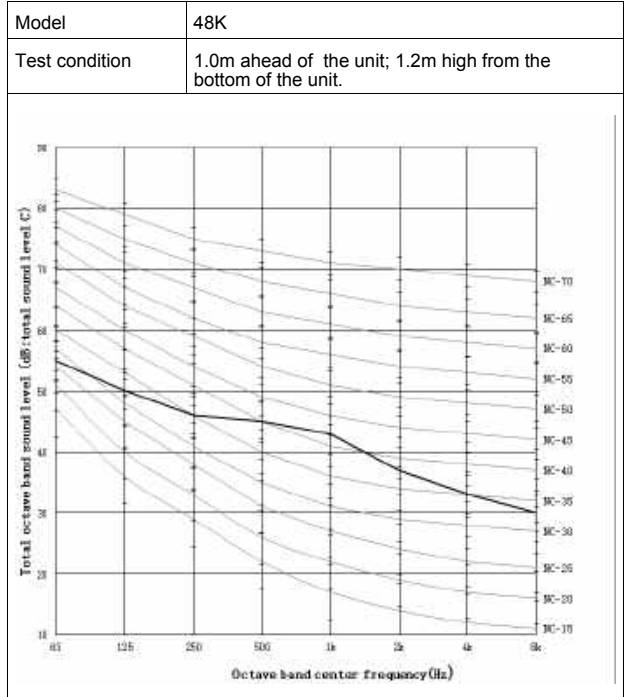
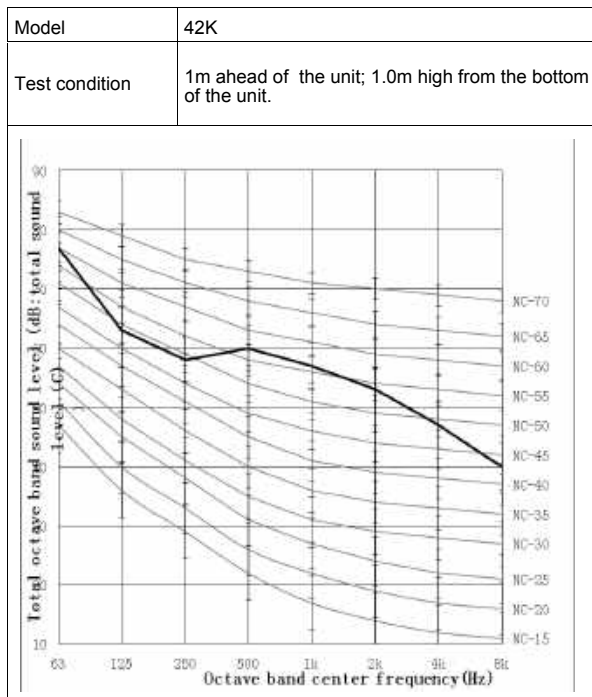
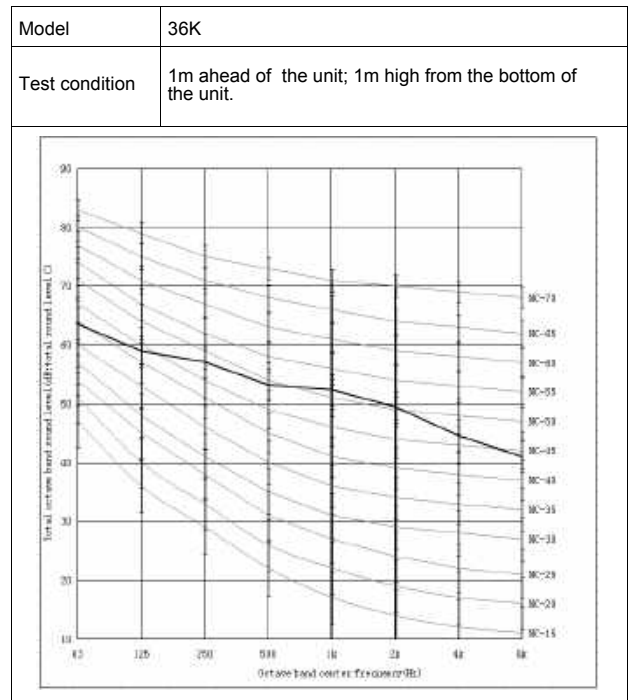
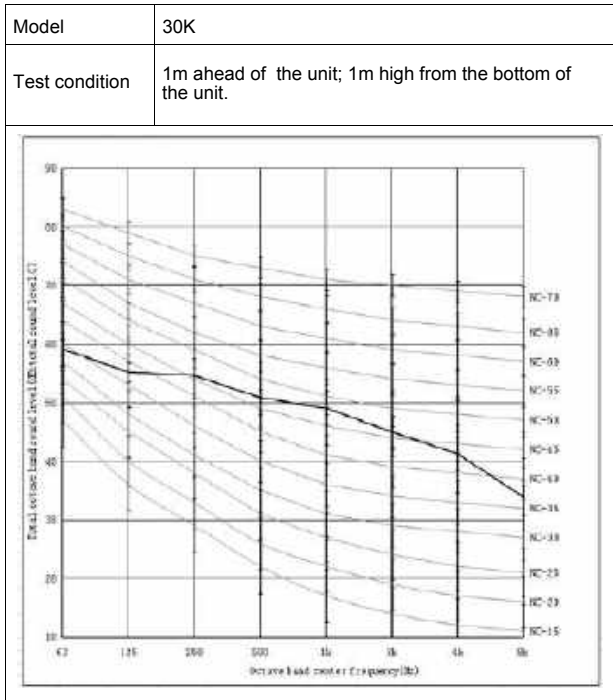

6. SOUND PRESSURE DATA

Model	60K
Test condition	1.0m ahead of the unit; 1.2m high from the bottom of the unit.

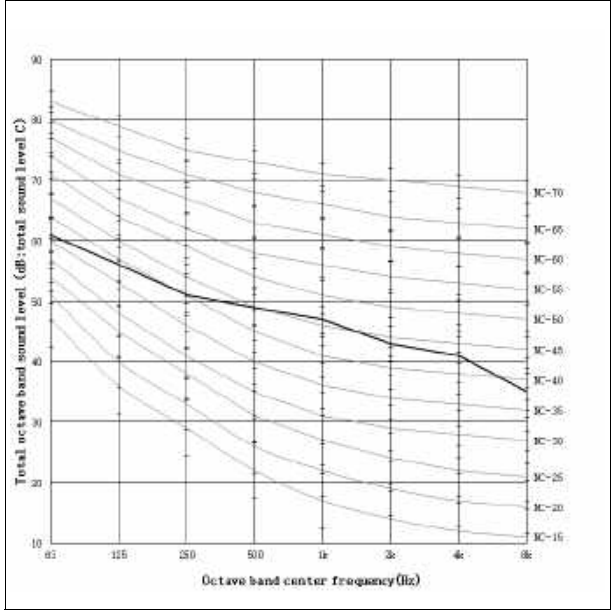

7. AIR FLOW DISTRIBUTION

7. Air flow distribution

7.1 Cassette

9K

1) Cooling/ Air Velocity Distribution

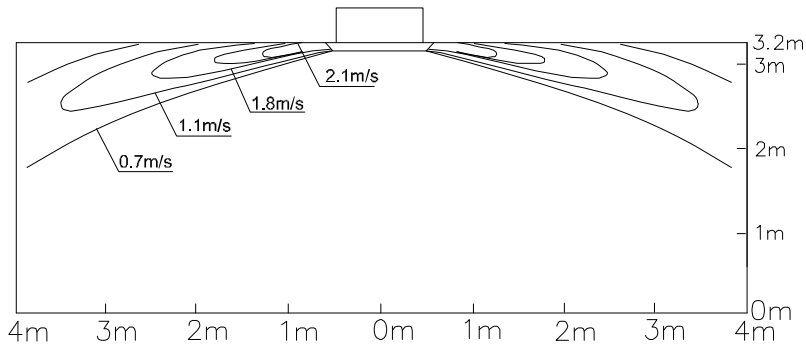

2) Cooling/ Air Temperature Distribution

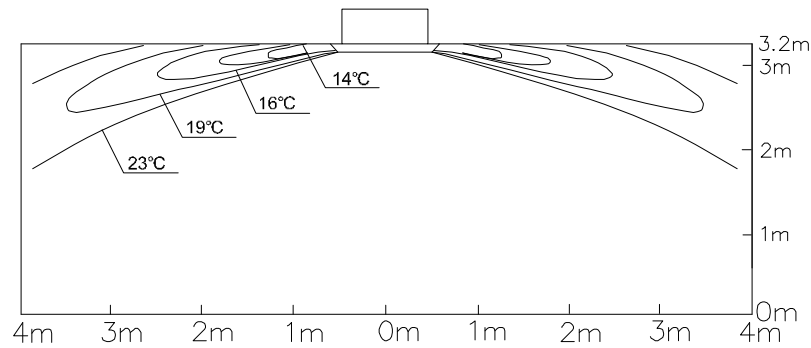

3) Heating/ Air Velocity Distribution

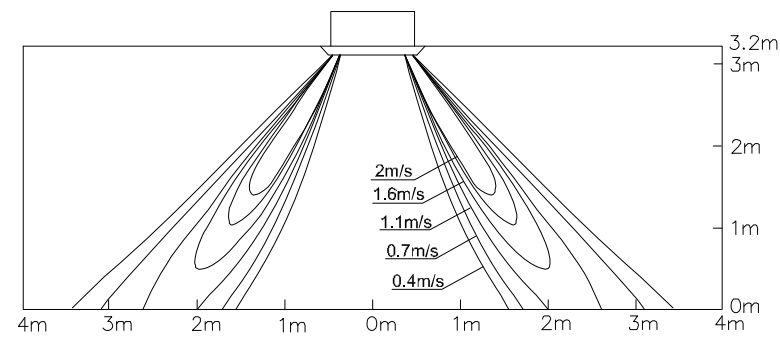

4) Heating/ Air Temperature Distribution

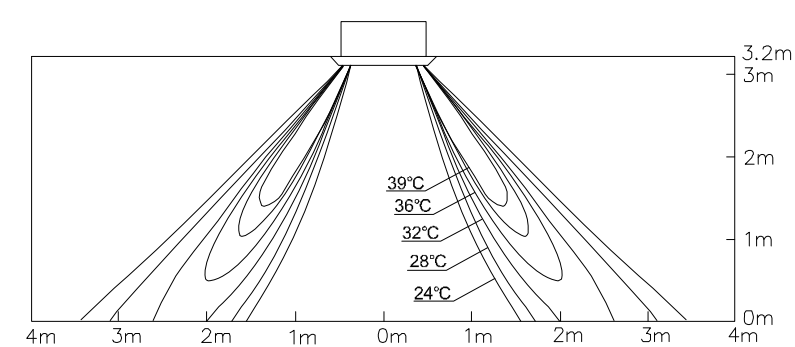

7. AIR FLOW DISTRIBUTION

12K

1) Cooling/ Air Velocity Distribution

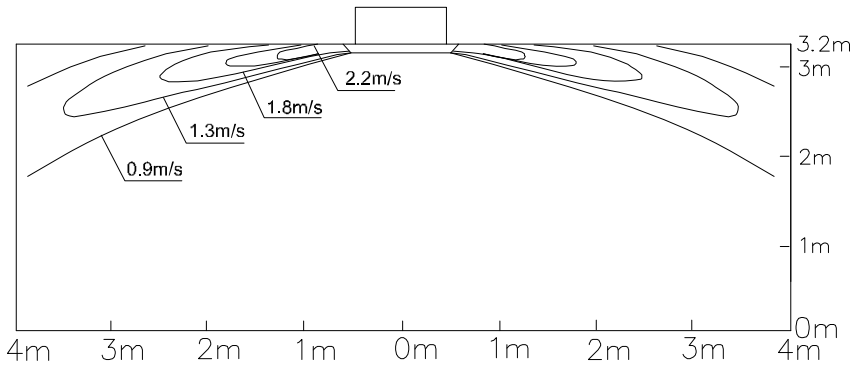

2) Cooling/ Air Temperature Distribution

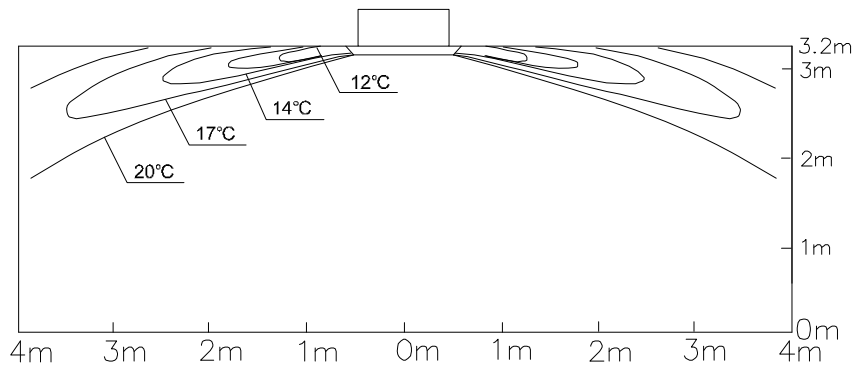

3) Heating/ Air Velocity Distribution

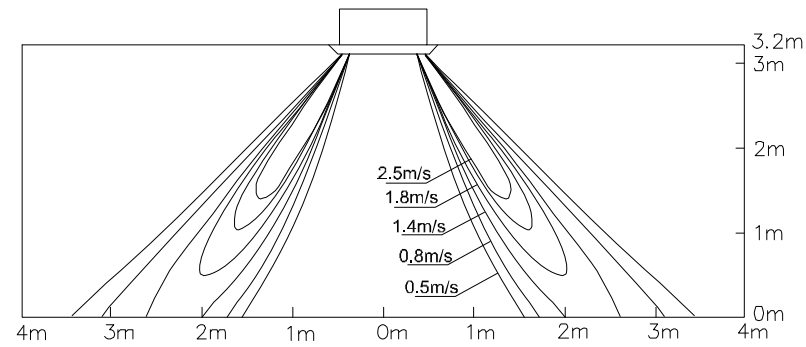

4) Heating/ Air Temperature Distribution

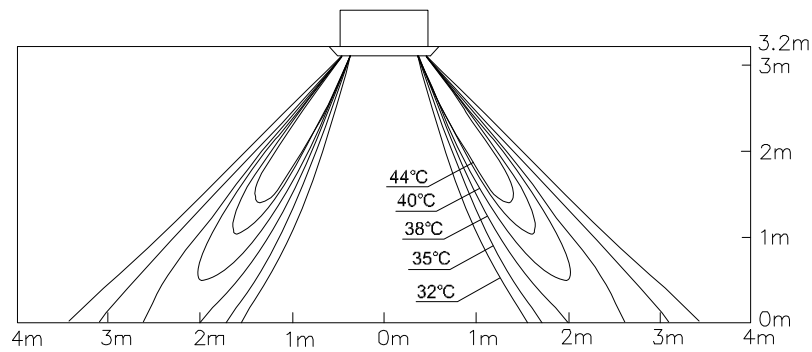

7. AIR FLOW DISTRIBUTION

18K

1) Cooling/ Air Velocity Distribution

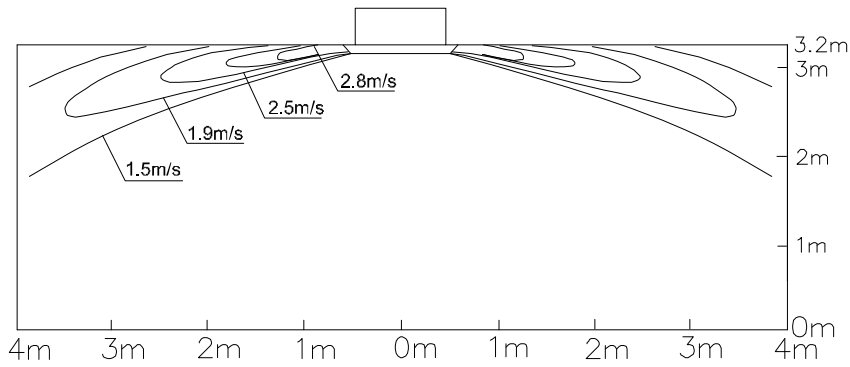

2) Cooling/ Air Temperature Distribution

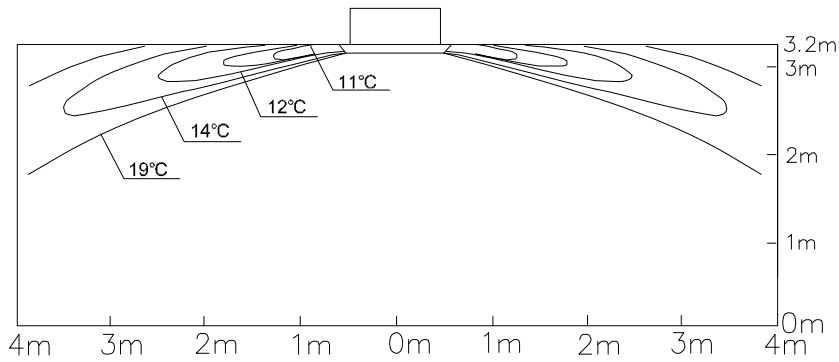

3) Heating/ Air Velocity Distribution

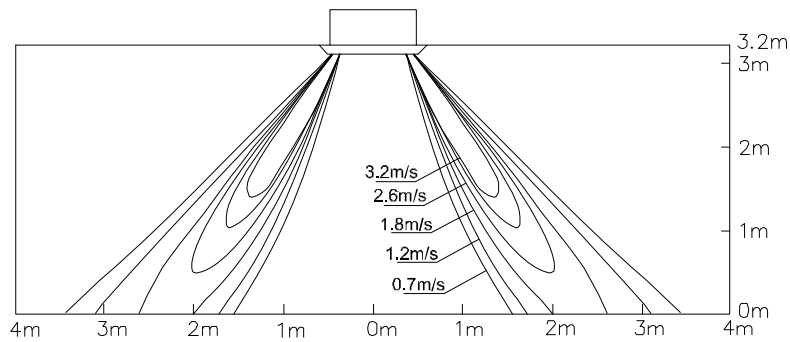

4) Heating/ Air Temperature Distribution

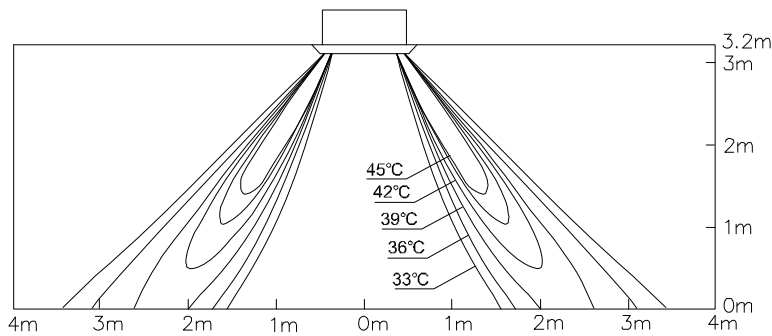

7. AIR FLOW DISTRIBUTION

24K

1) Cooling/ Air Velocity Distribution

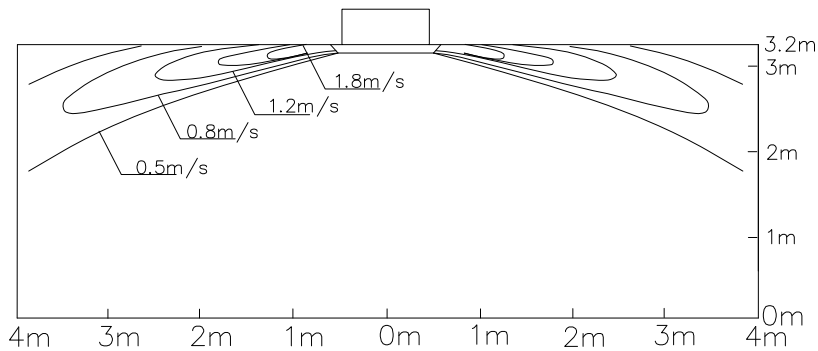

2) Cooling/ Air Temperature Distribution

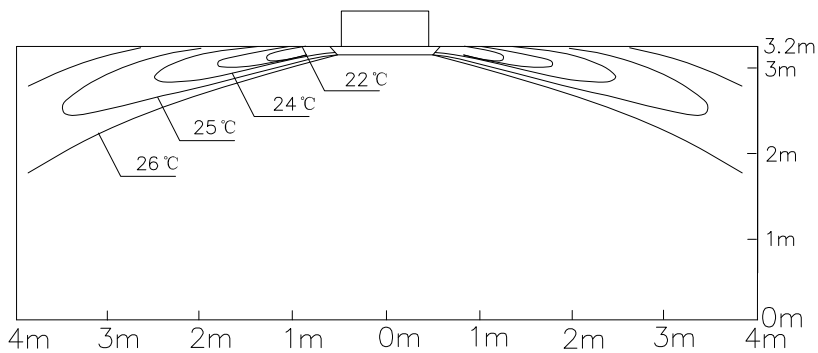

3) Heating/ Air Velocity Distribution

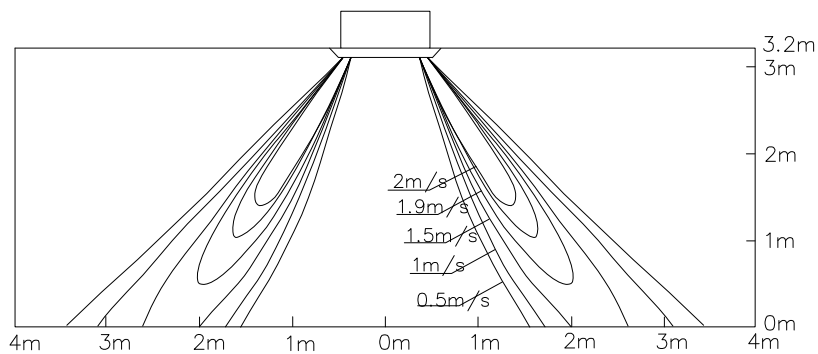

4) Heating/ Air Temperature Distribution

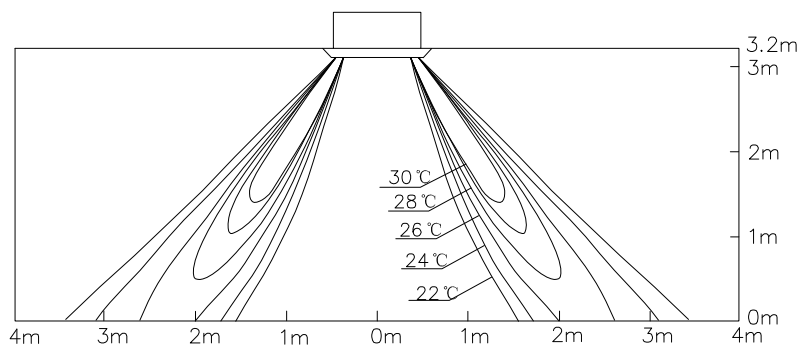

7. AIR FLOW DISTRIBUTION

30K

1) Cooling/ Air Velocity Distribution

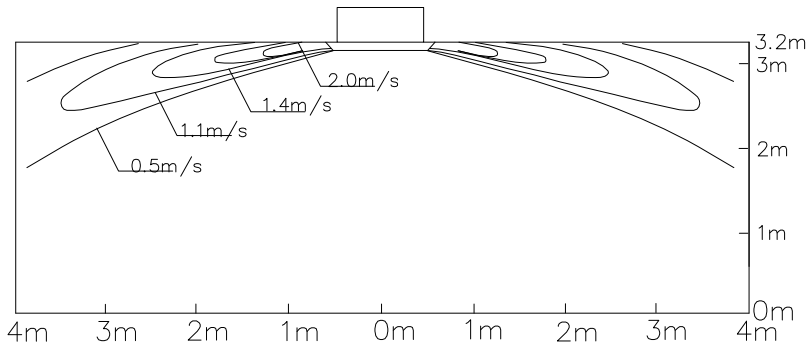

2) Cooling/ Air Temperature Distribution

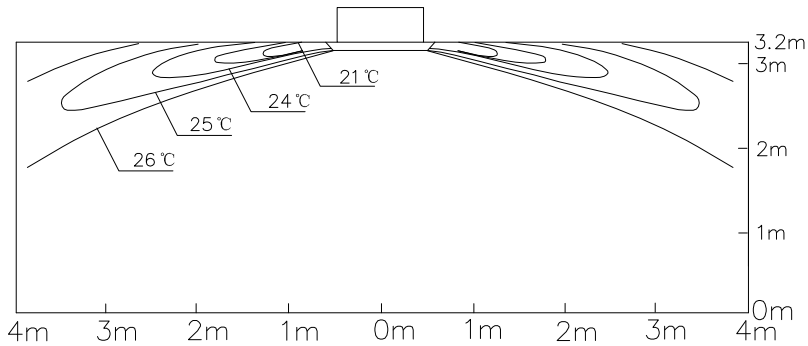

3) Heating/ Air Velocity Distribution

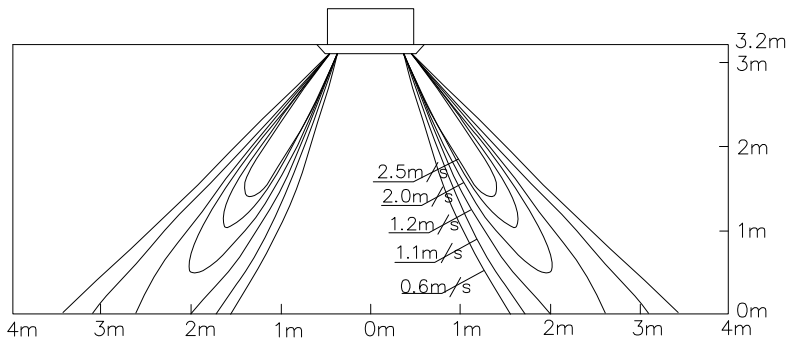

4) Heating/ Air Temperature Distribution

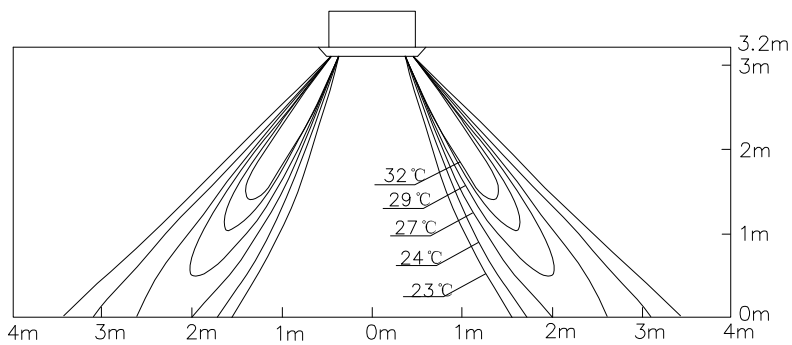

7. AIR FLOW DISTRIBUTION

36K

1) Cooling/ Air Velocity Distribution

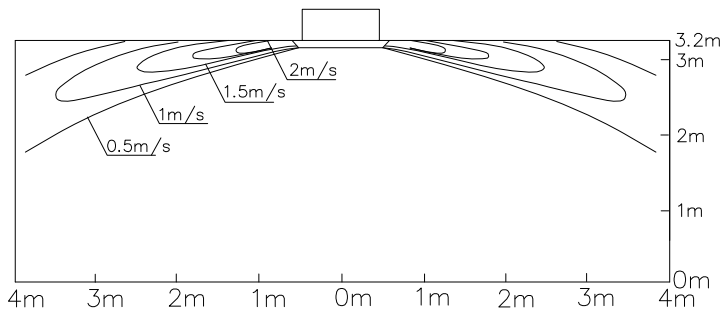

2) Cooling/ Air Temperature Distribution

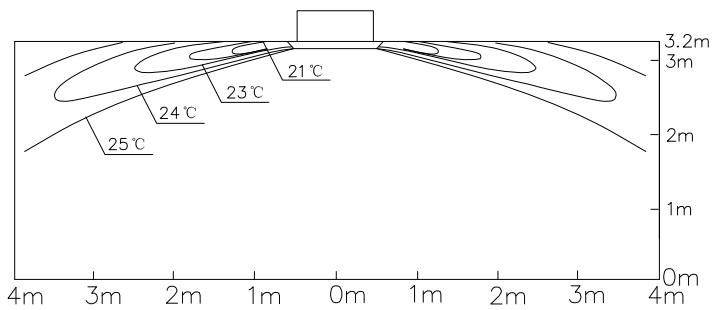

3) Heating/ Air Velocity Distribution

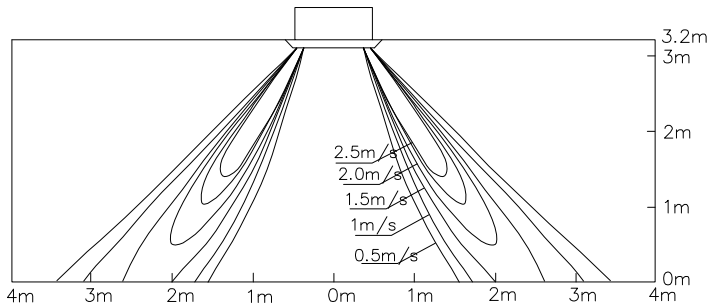

4) Heating/ Air Temperature Distribution

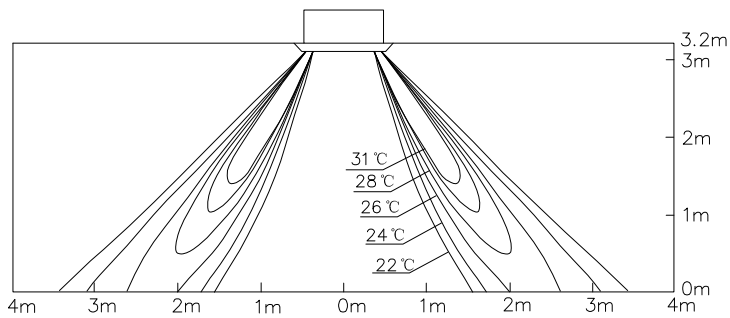

7. AIR FLOW DISTRIBUTION

42K

1) Cooling/ Air Velocity Distribution

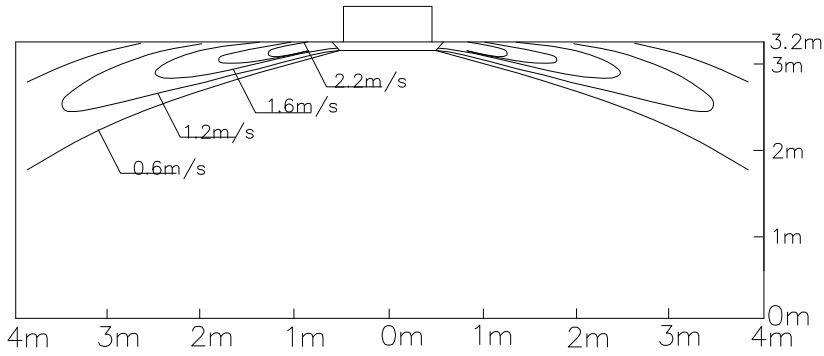

2) Cooling/ Air Temperature Distribution

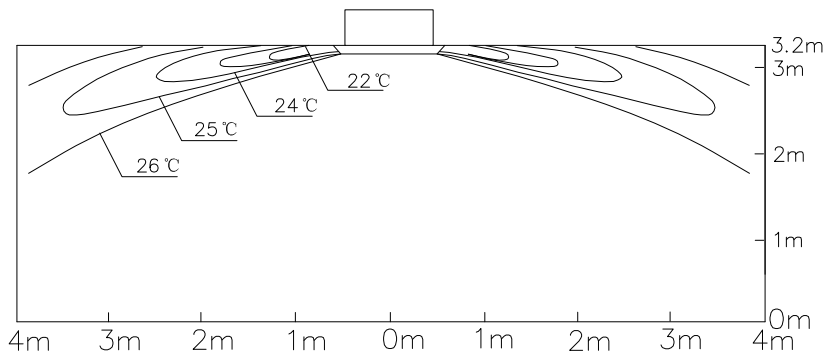

3) Heating/ Air Velocity Distribution

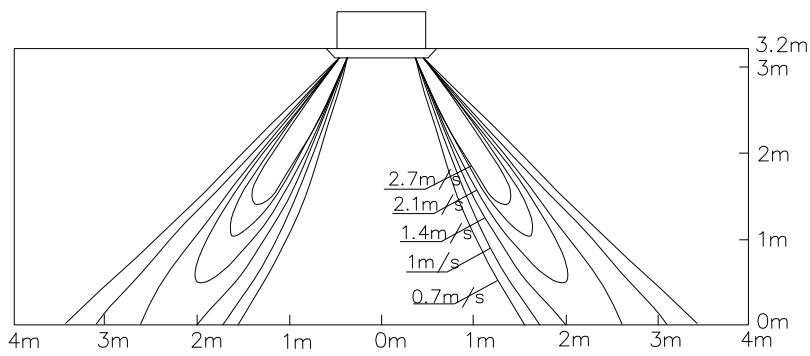

4) Heating/ Air Temperature Distribution

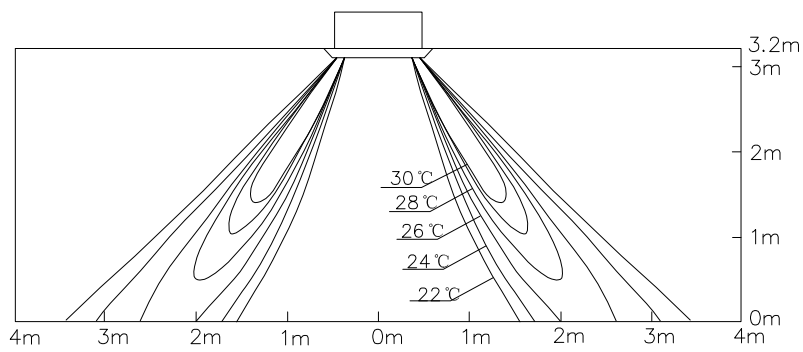

7. AIR FLOW DISTRIBUTION

48K

1) Cooling/ Air Velocity Distribution

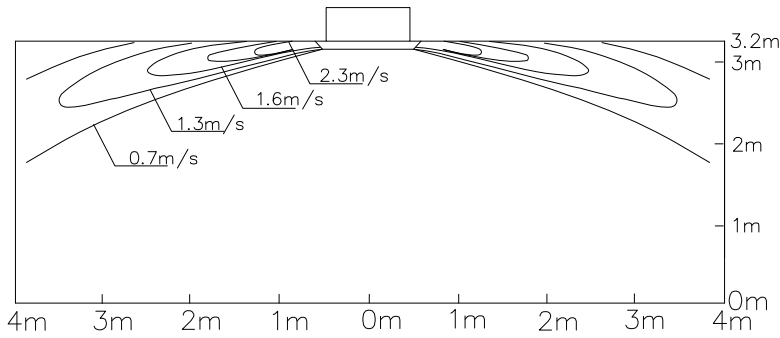

2) Cooling/ Air Temperature Distribution

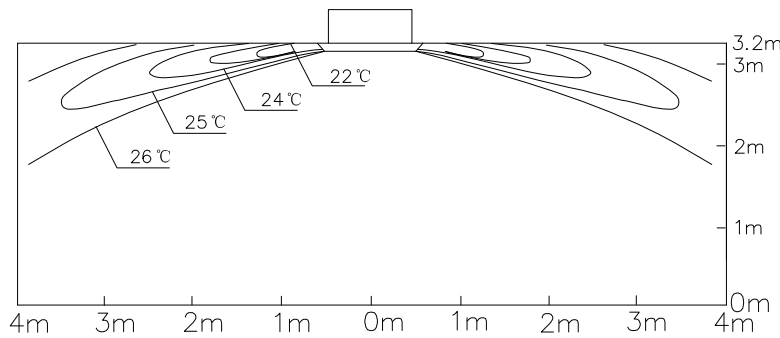

3) Heating/ Air Velocity Distribution

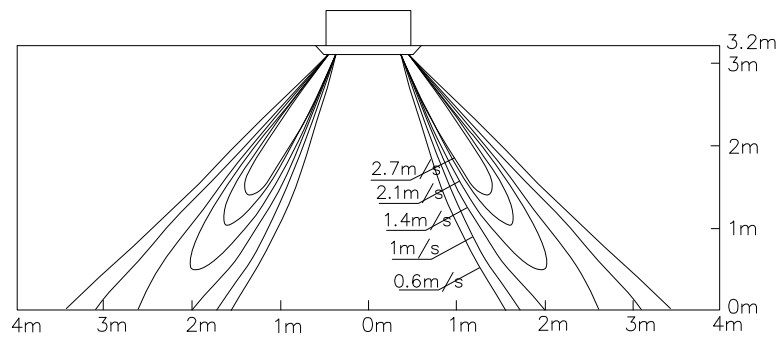

4) Heating/ Air Temperature Distribution

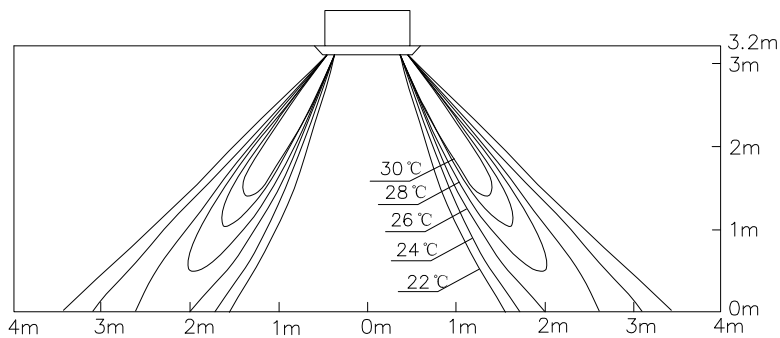

7. AIR FLOW DISTRIBUTION

60K

1) Cooling/ Air Velocity Distribution

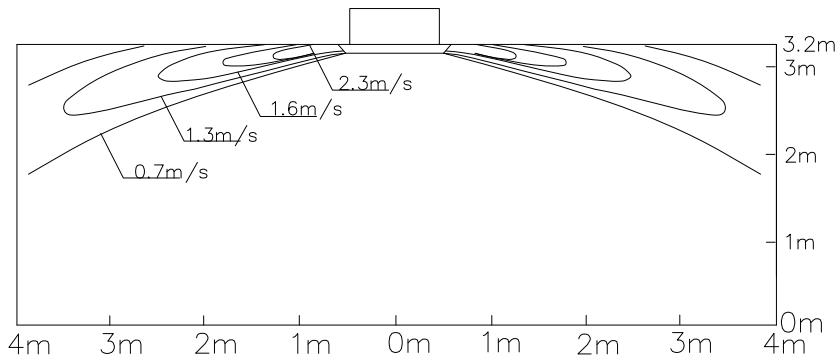

2) Cooling/ Air Temperature Distribution

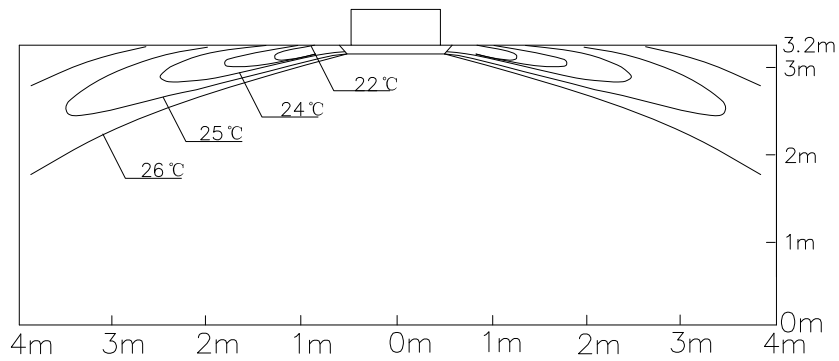

3) Heating/ Air Velocity Distribution (Blow angle: XX)

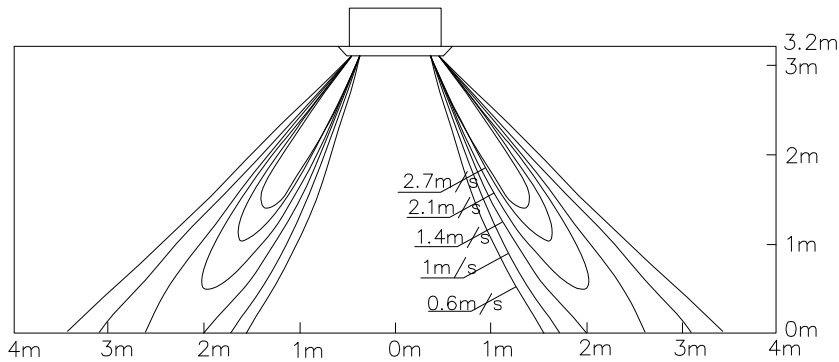

4) Heating/ Air Temperature Distribution

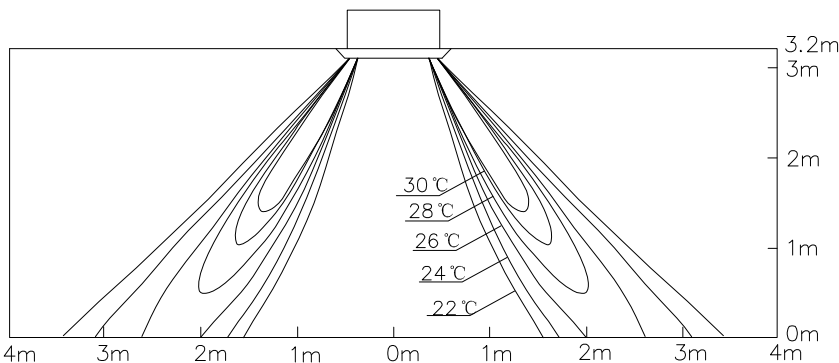

7. AIR FLOW DISTRIBUTION

7.2 Ceiling & Floor

18K

1) Ceiling install/Cooling/ Air Velocity Distribution

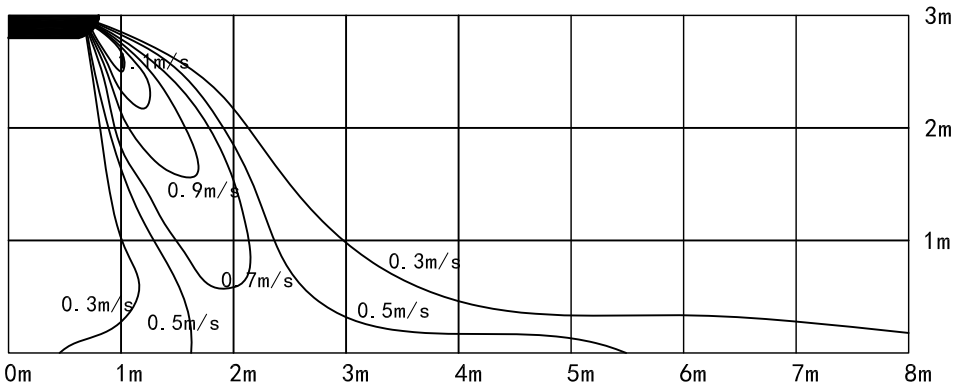

2) Ceiling install/Cooling/ Air Temperature Distribution

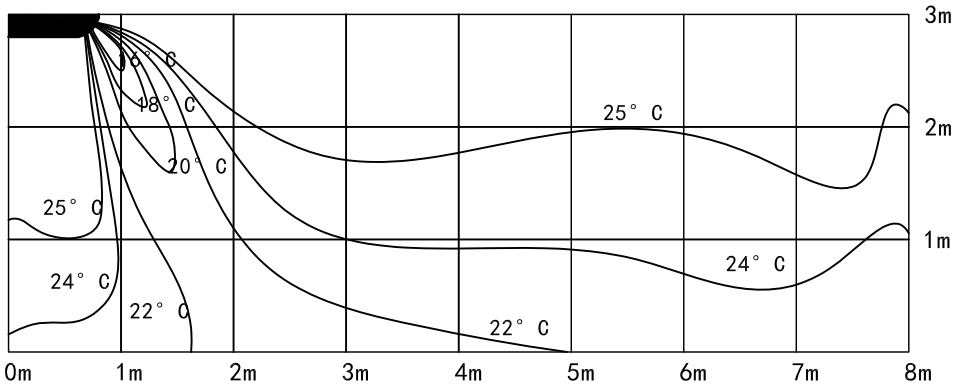

3) Ceiling install/Heating/ Air Velocity Distribution

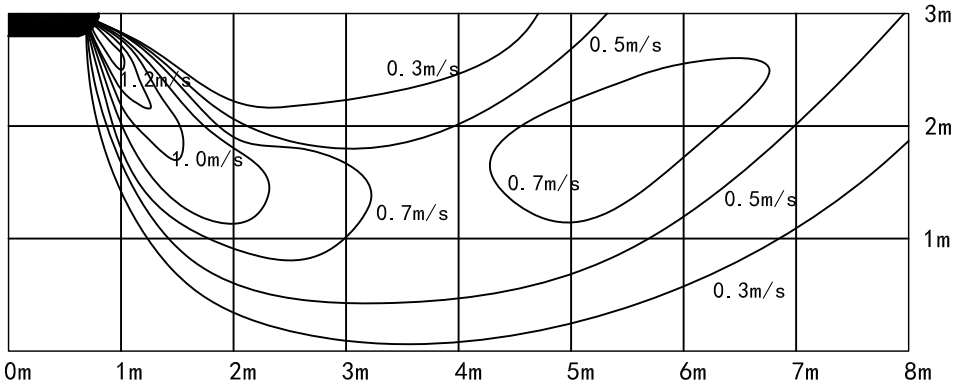

4) Heating/ Air Temperature Distribution

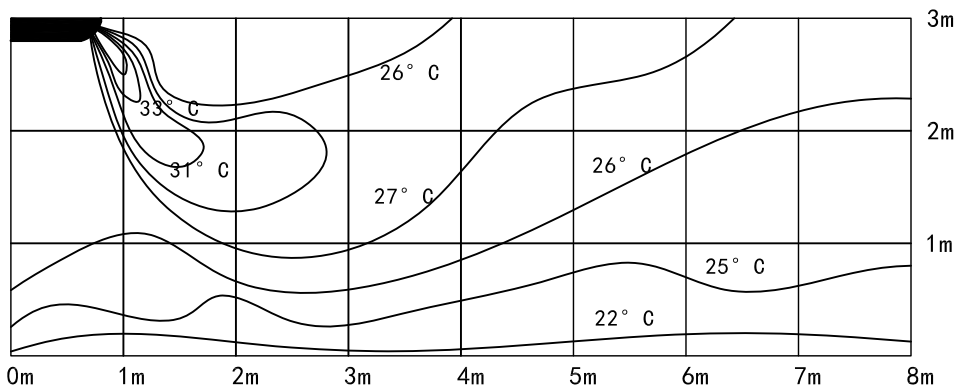

7. AIR FLOW DISTRIBUTION

5) Floor install/Cooling/ Air Velocity Distribution

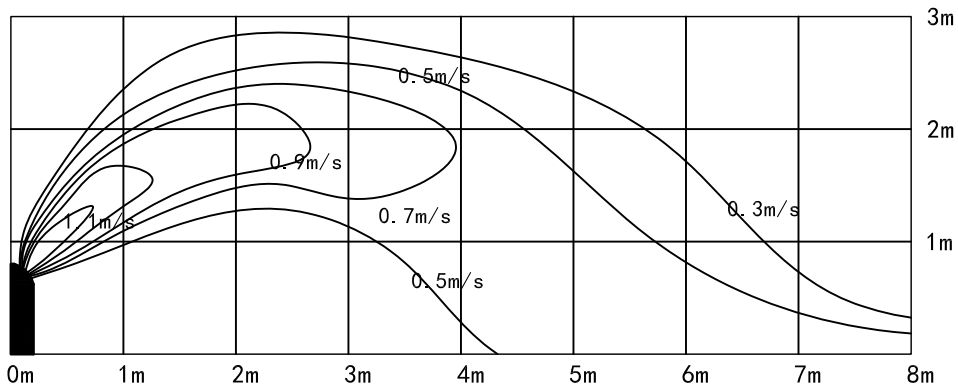

6) Floor install/Cooling/ Air Temperature Distribution

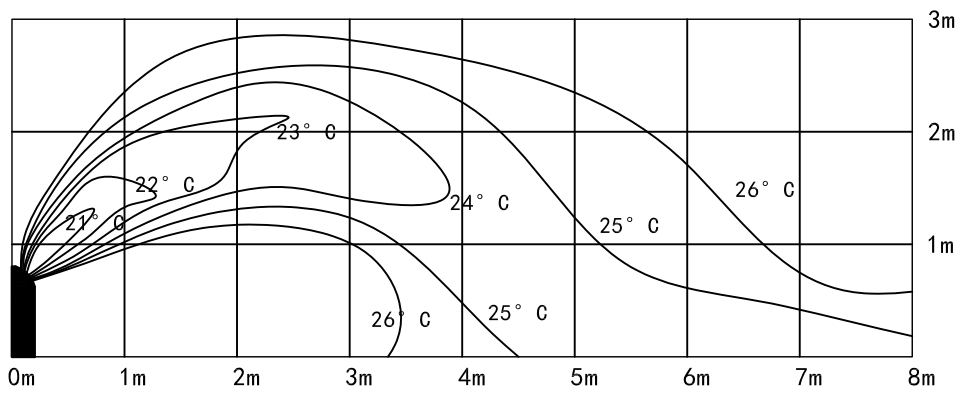

7) Floor install/Heating/ Air Velocity Distribution

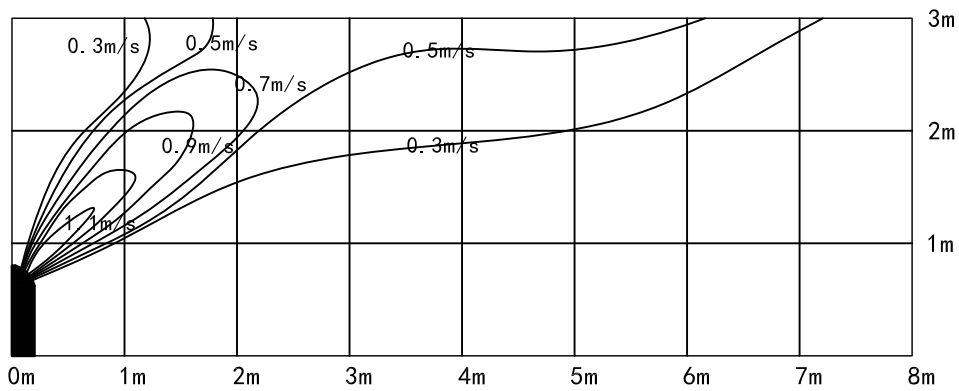

8) Floor install/Heating/ Air Temperature Distribution

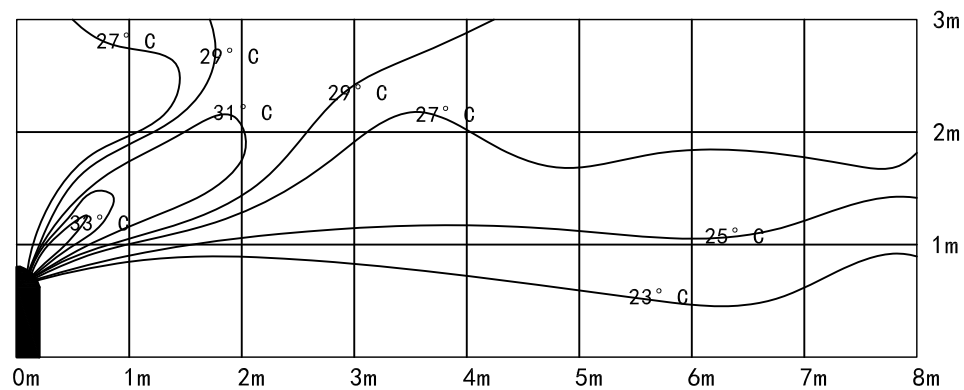

7. AIR FLOW DISTRIBUTION

24K

1) Ceiling install/Cooling/ Air Velocity Distribution

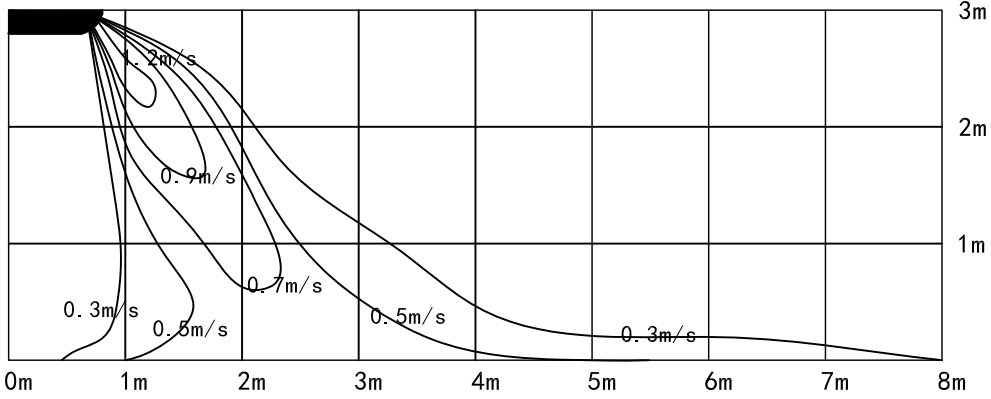

2) Ceiling install/Cooling/ Air Temperature Distribution

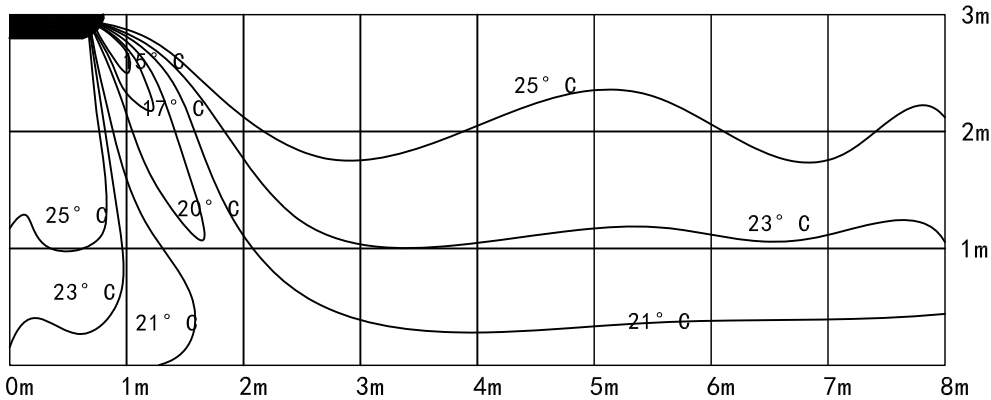

3) Ceiling install/Heating/ Air Velocity Distribution

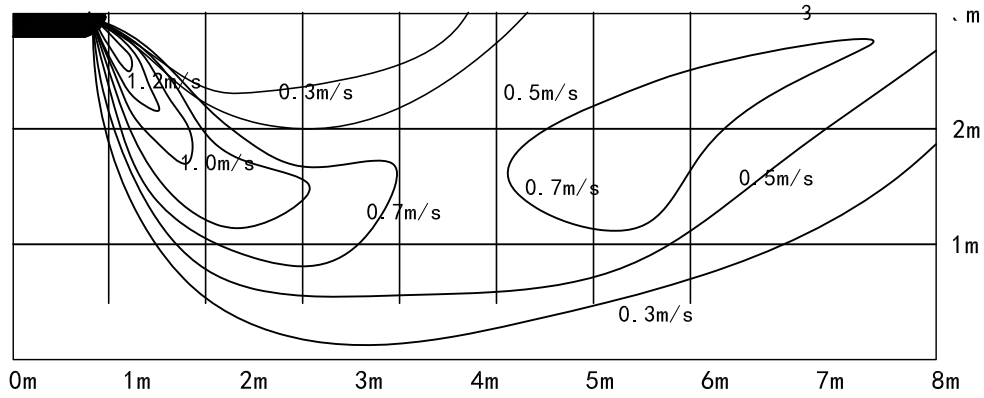

4) Heating/ Air Temperature Distribution

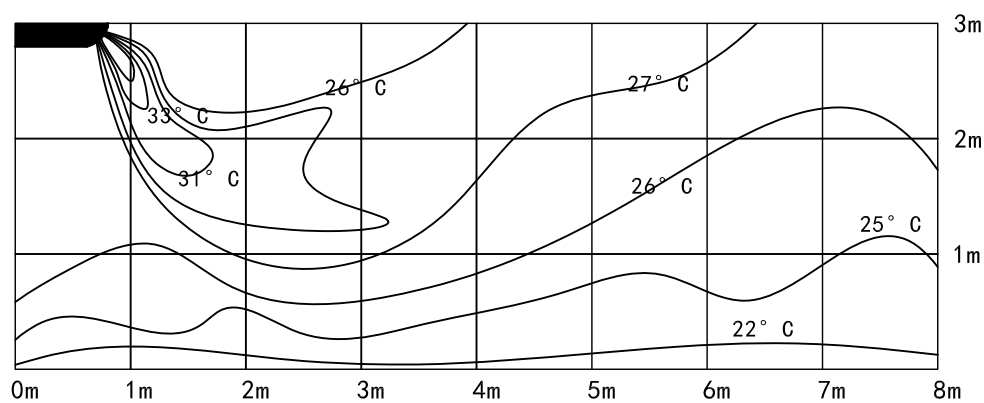

7. AIR FLOW DISTRIBUTION

5) Floor install/Cooling/ Air Velocity Distribution

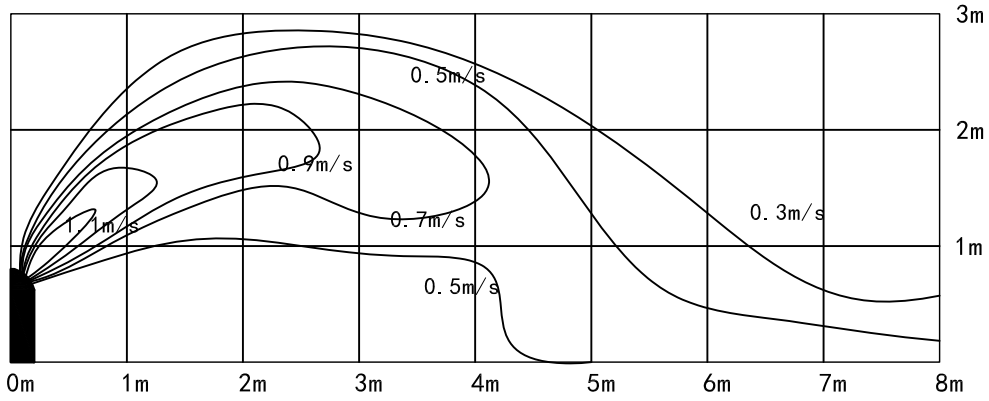

6) Floor install/Cooling/ Air Temperature Distribution

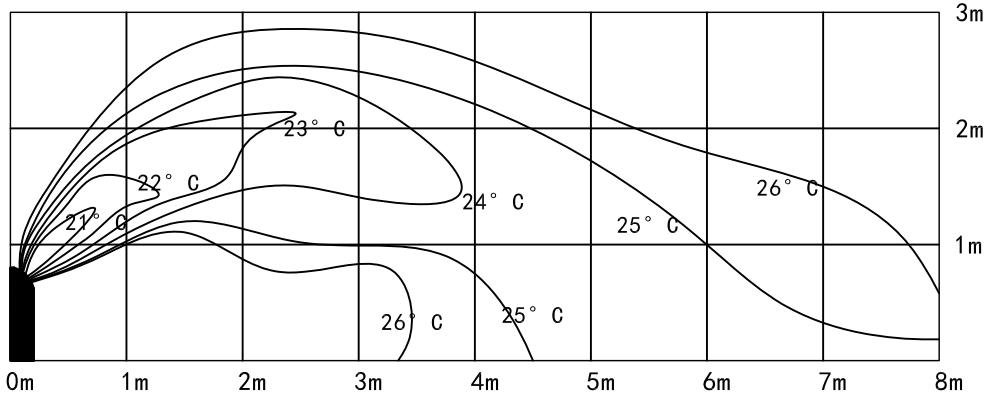

7) Floor install/Heating/ Air Velocity Distribution

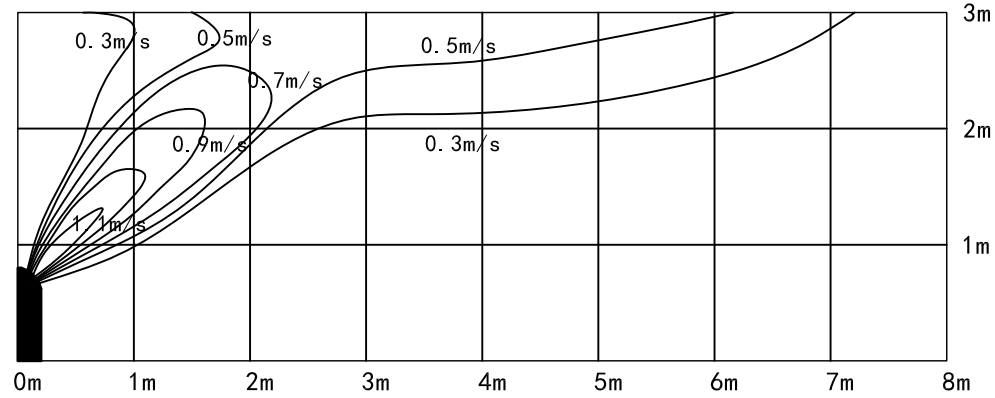

8) Floor install/Heating/ Air Temperature Distribution

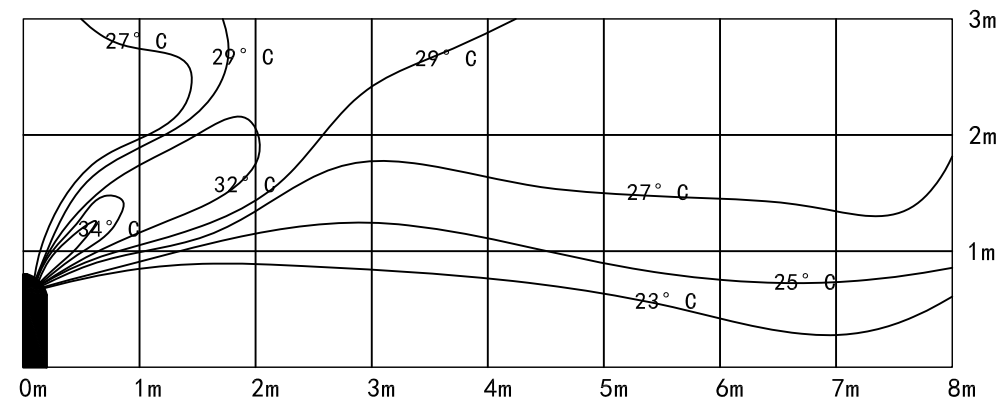

7. AIR FLOW DISTRIBUTION

30K

1) Ceiling install/Cooling/ Air Velocity Distribution

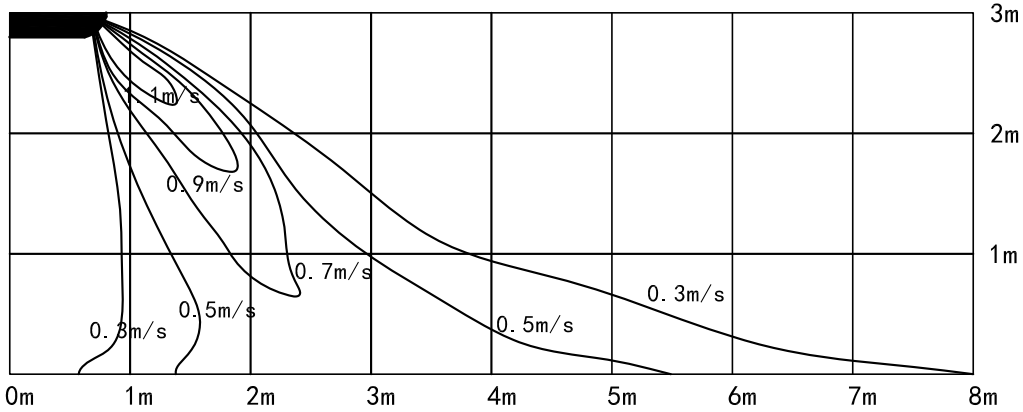

2) Ceiling install/Cooling/ Air Temperature Distribution

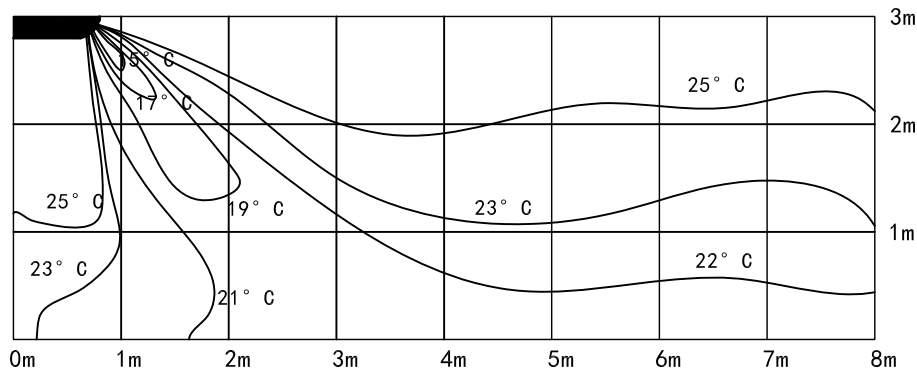

3) Ceiling install/Heating/ Air Velocity Distribution

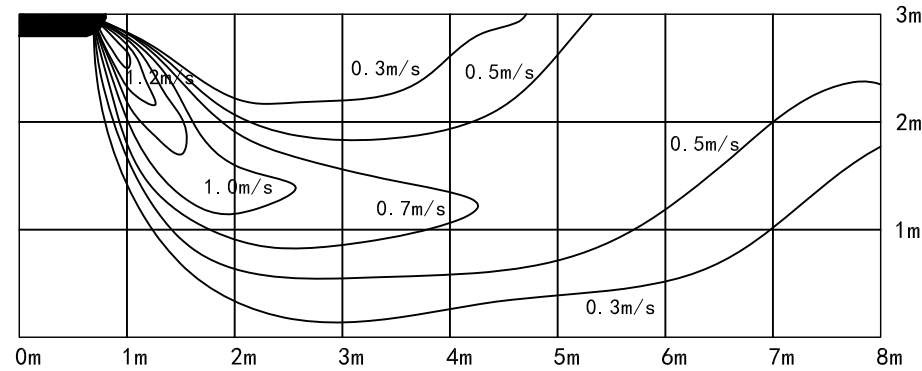

4) Ceiling install/Heating/ Air Temperature Distribution

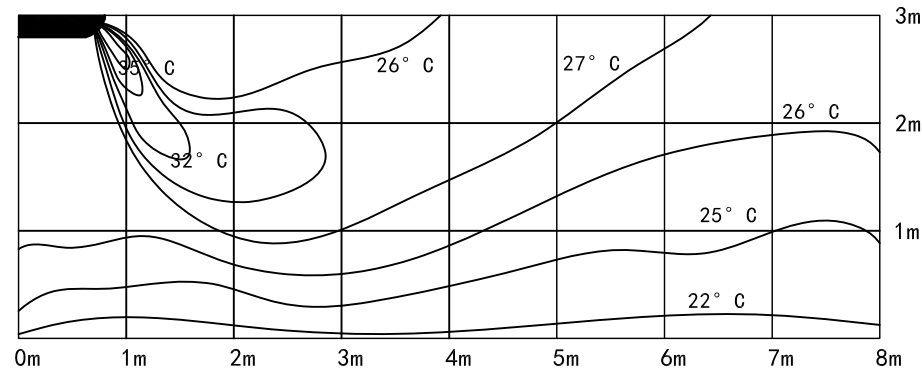

7. AIR FLOW DISTRIBUTION

5) Floor install/Cooling/ Air Velocity Distribution

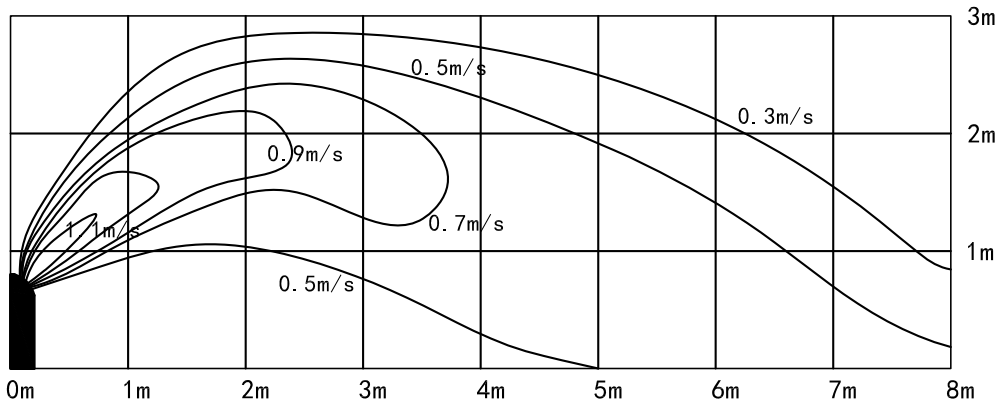

6) Floor install/Cooling/ Air Temperature Distribution

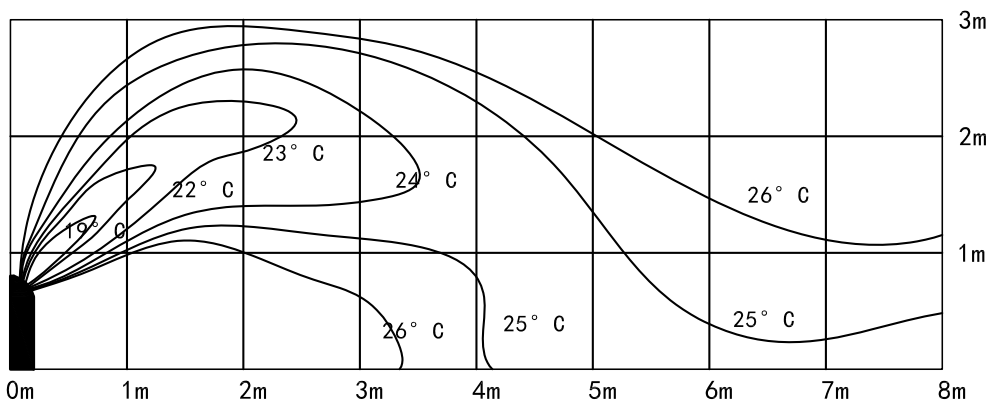

7) Floor install/Heating/ Air Velocity Distribution

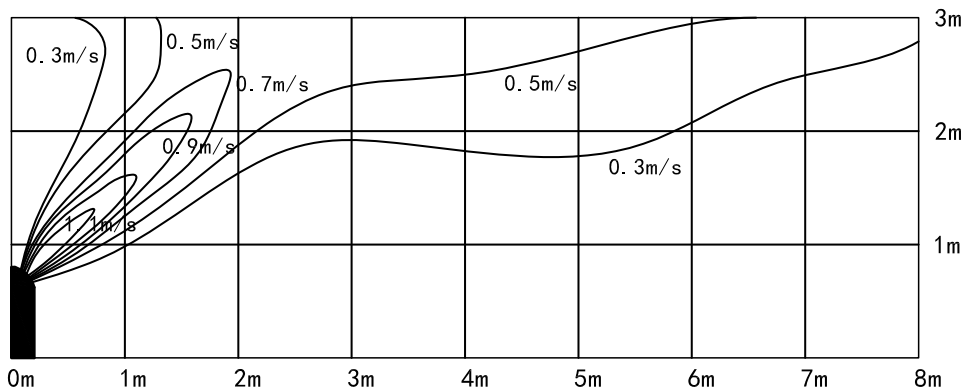

8) Floor install/Heating/ Air Temperature Distribution

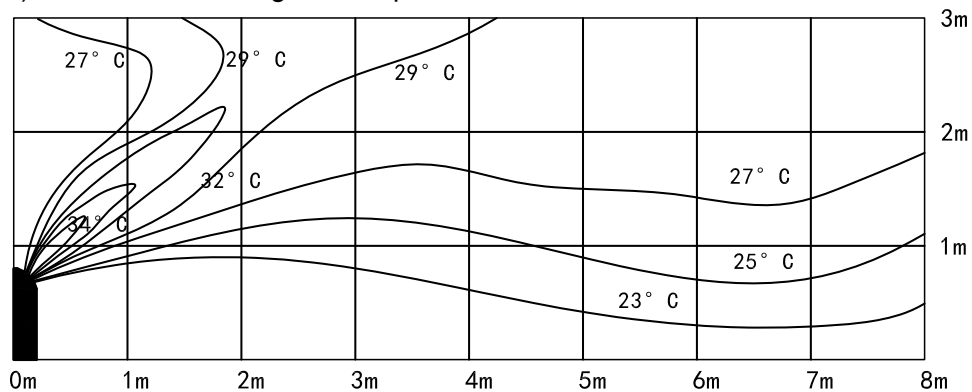

7. AIR FLOW DISTRIBUTION

36K

1) Ceiling install/Cooling/ Air Velocity Distribution

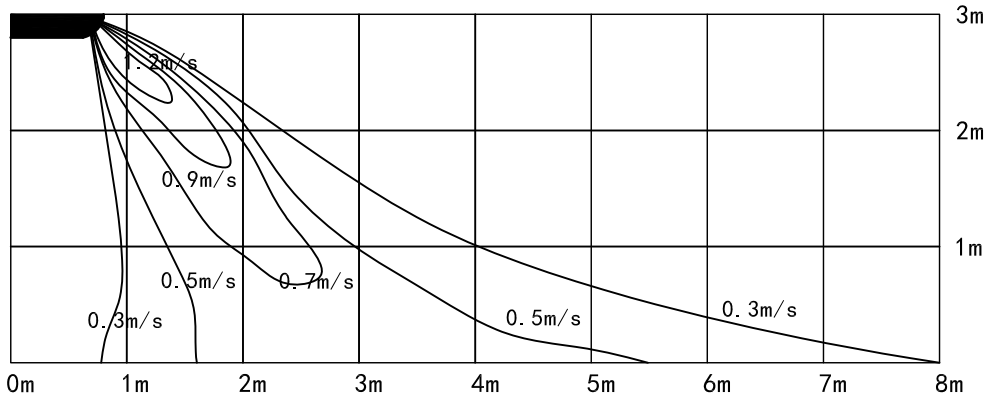

2) Ceiling install/Cooling/ Air Temperature Distribution

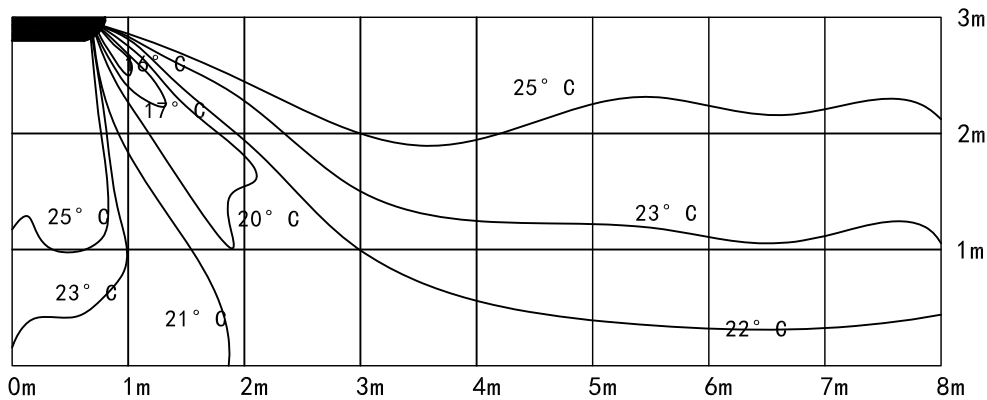

3) Ceiling install/Heating/ Air Velocity Distribution

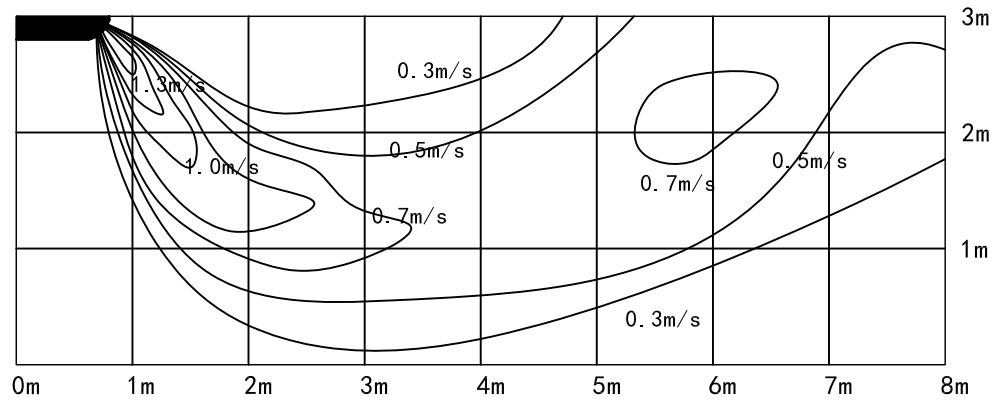

4) Ceiling install/Heating/ Air Temperature Distribution

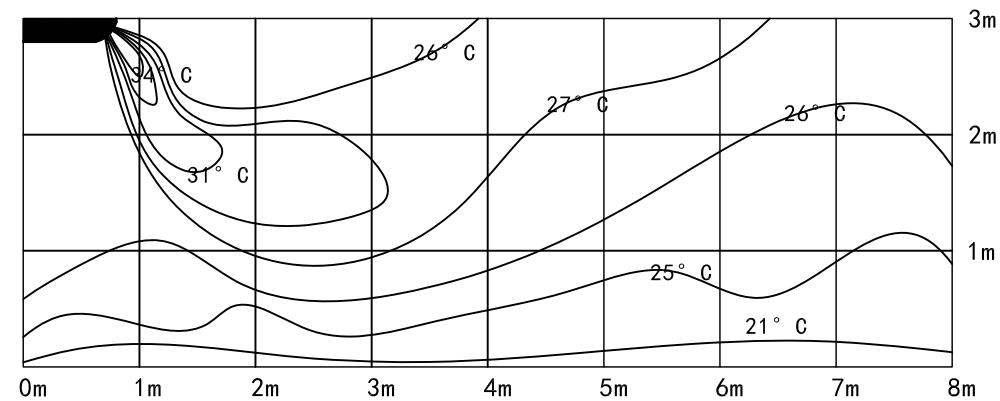

7. AIR FLOW DISTRIBUTION

5) Floor install/Cooling/ Air Velocity Distribution

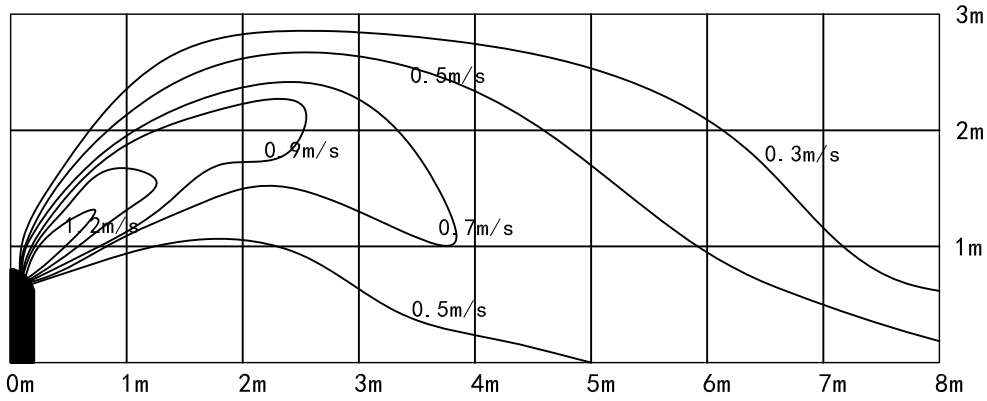

6) Floor install/Cooling/ Air Temperature Distribution

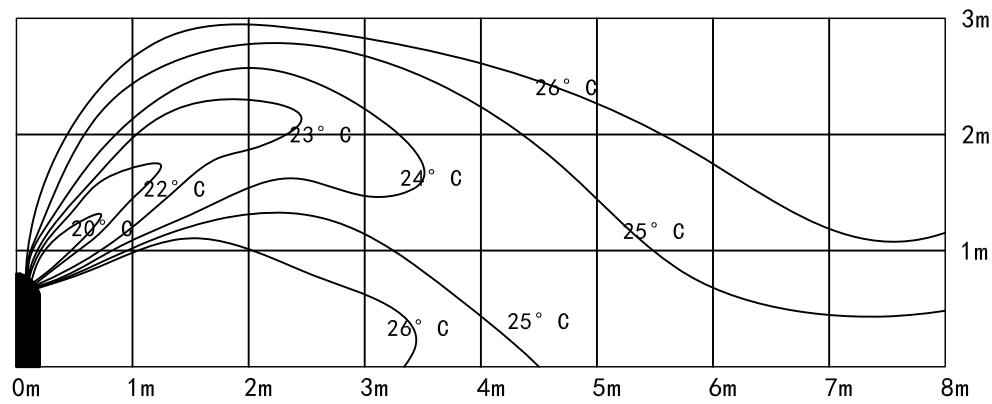

7) Floor install/Heating/ Air Velocity Distribution

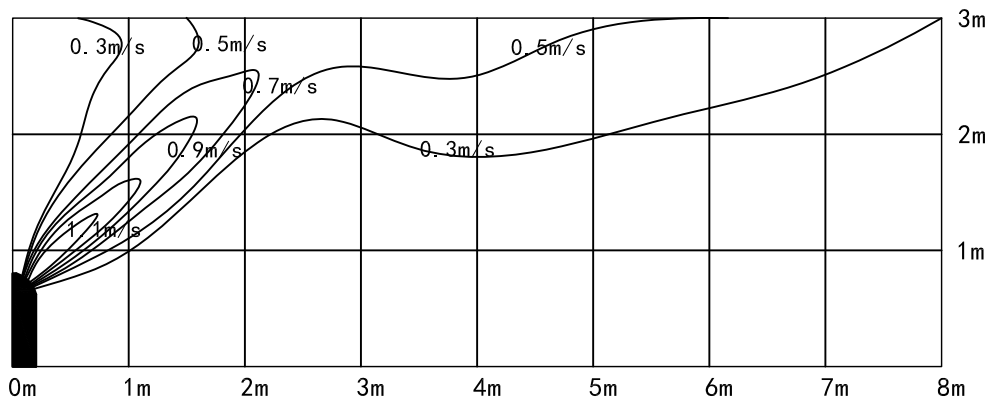

8) Floor install/Heating/ Air Temperature Distribution

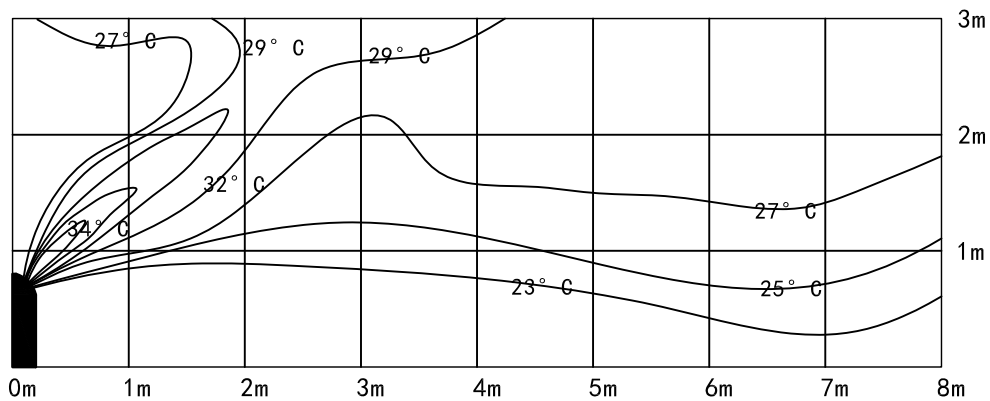

7. AIR FLOW DISTRIBUTION

42K

1) Floor install/Cooling/ Air Velocity Distribution

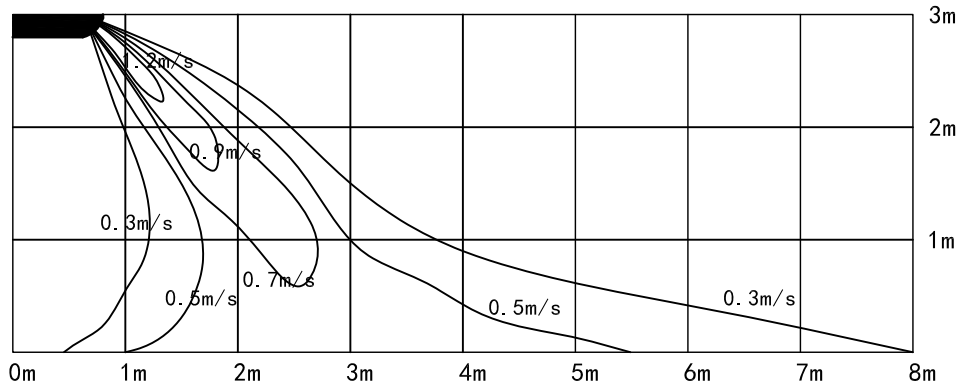

2) Floor install/Cooling/ Air Temperature Distribution

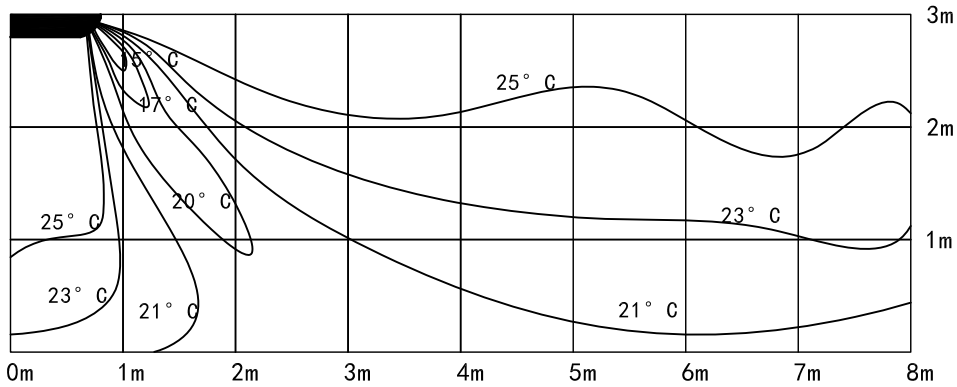

3) Floor install/Heating/ Air Velocity Distribution

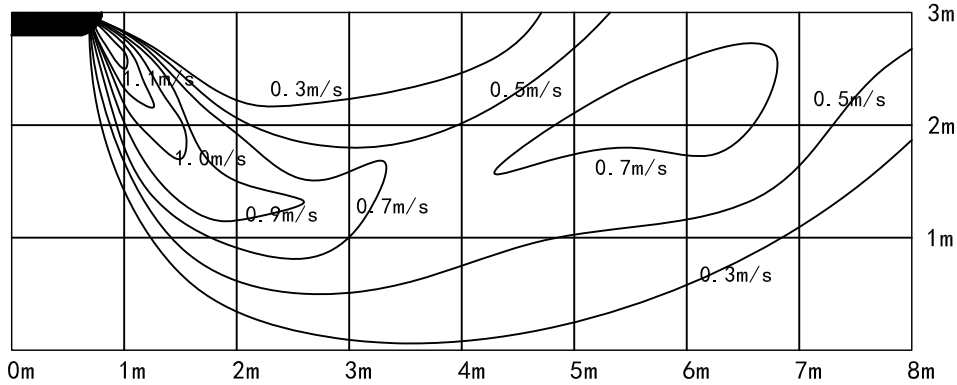

4) Floor install/Heating/ Air Temperature Distribution

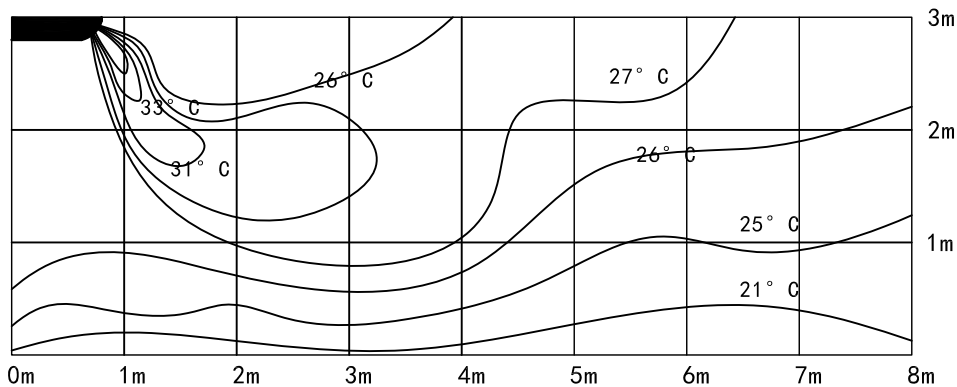

7. AIR FLOW DISTRIBUTION

5) Floor install/Cooling/ Air Velocity Distribution

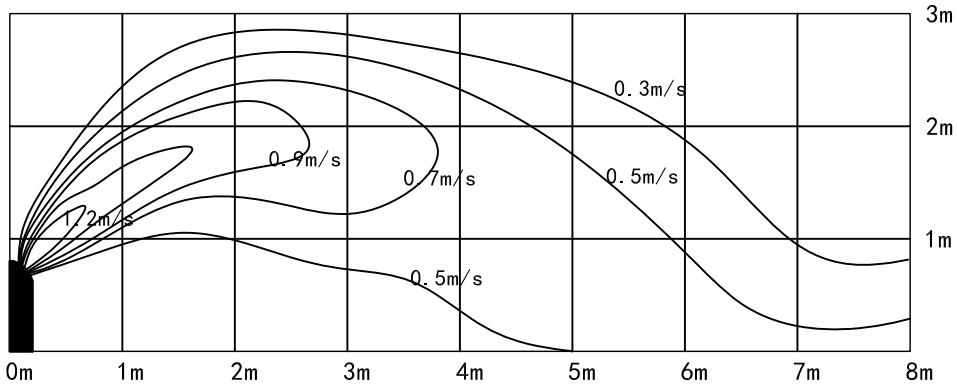

6) Floor install/Cooling/ Air Temperature Distribution

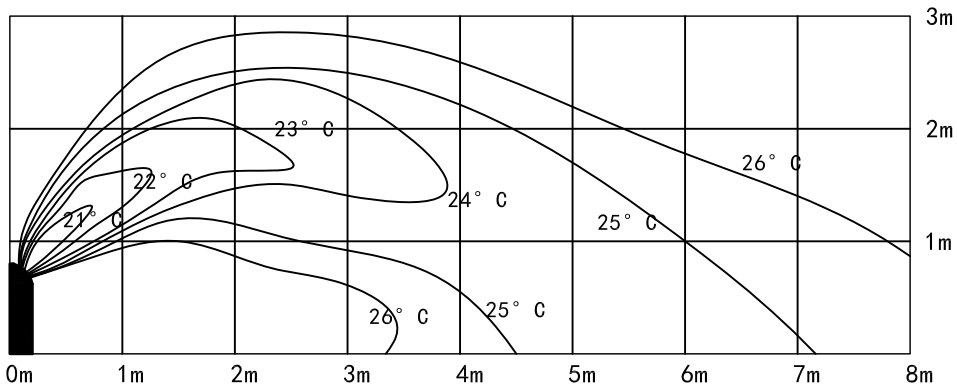

7) Floor install/Heating/ Air Velocity Distribution

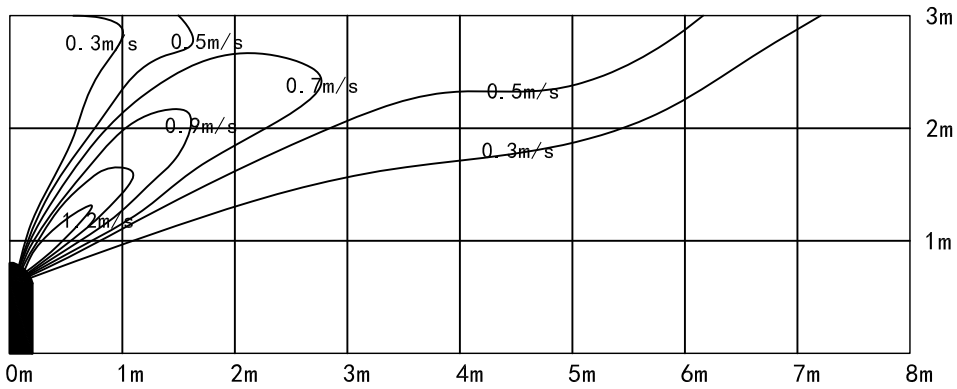

8) Floor install/Heating/ Air Temperature Distribution

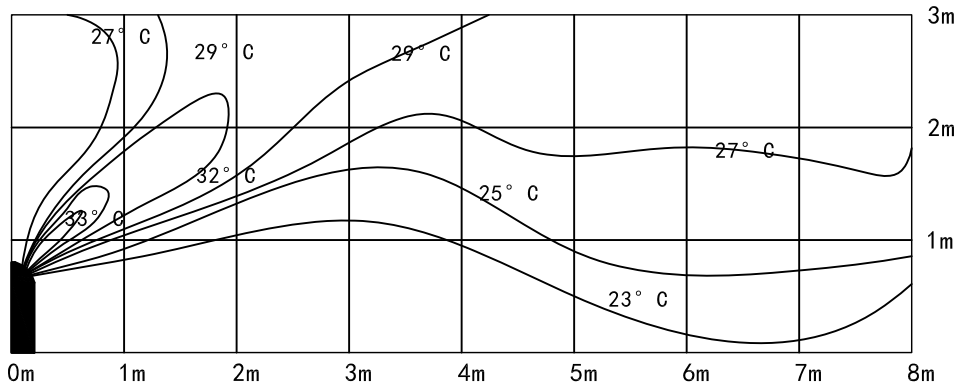

7. AIR FLOW DISTRIBUTION

48K

1) Ceiling install/Cooling/ Air Velocity Distribution

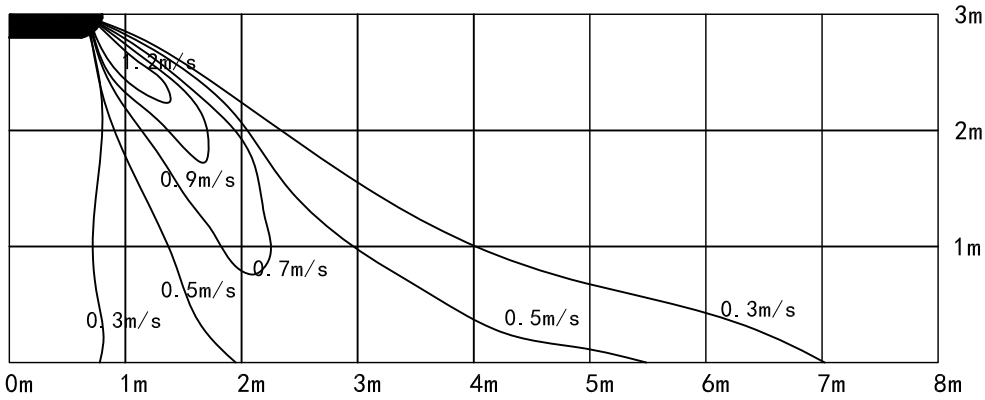

2) Ceiling install/Cooling/ Air Temperature Distribution

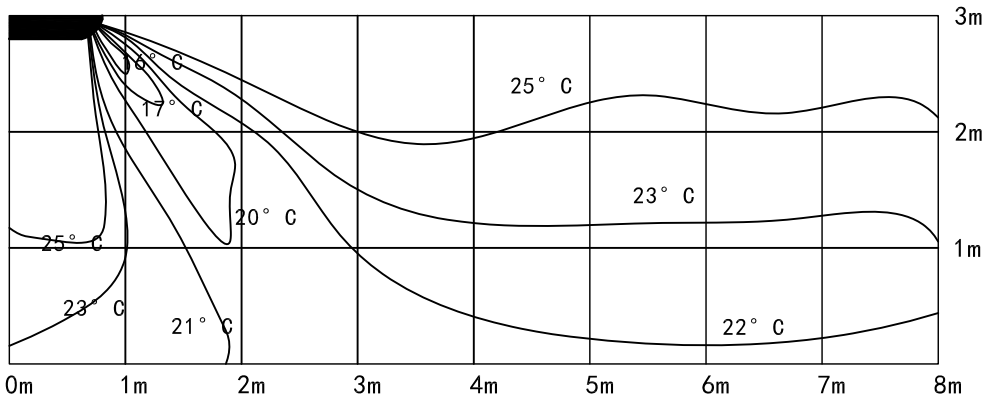

3) Ceiling install/Heating/ Air Velocity Distribution

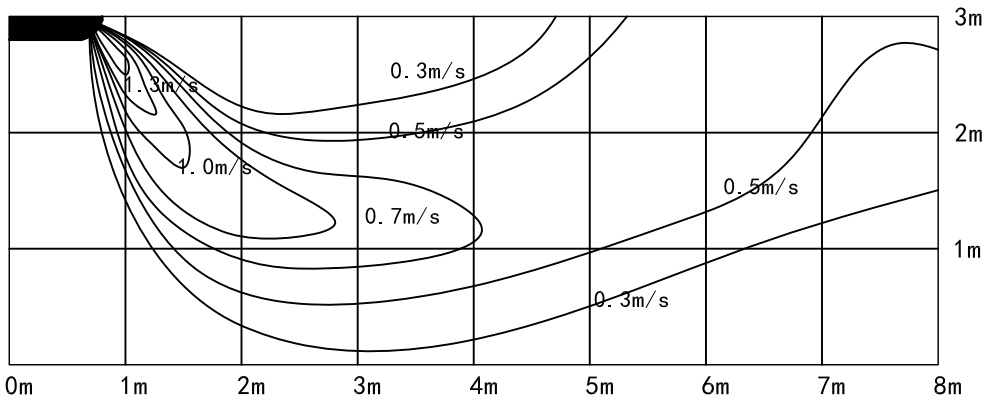

4) Ceiling install/Heating/ Air Temperature Distribution

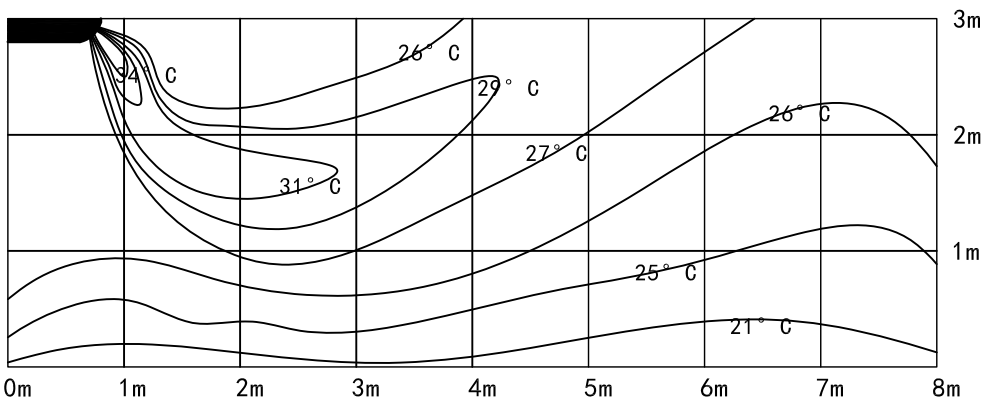

7. AIR FLOW DISTRIBUTION

5) Floor install/Cooling/ Air Velocity Distribution

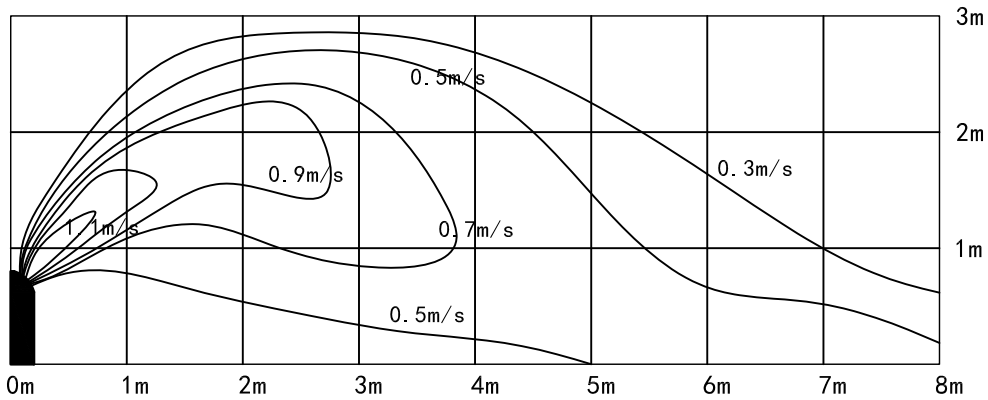

6) Floor install/Cooling/ Air Temperature Distribution

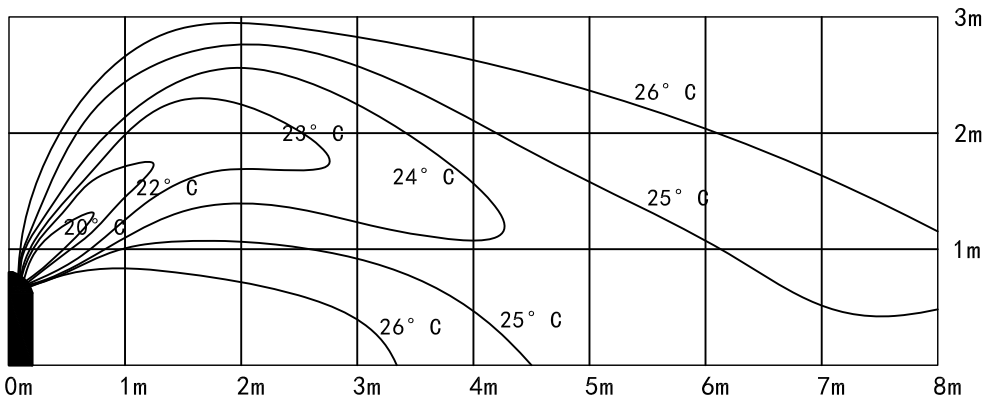

7) Floor install/Heating/ Air Velocity Distribution

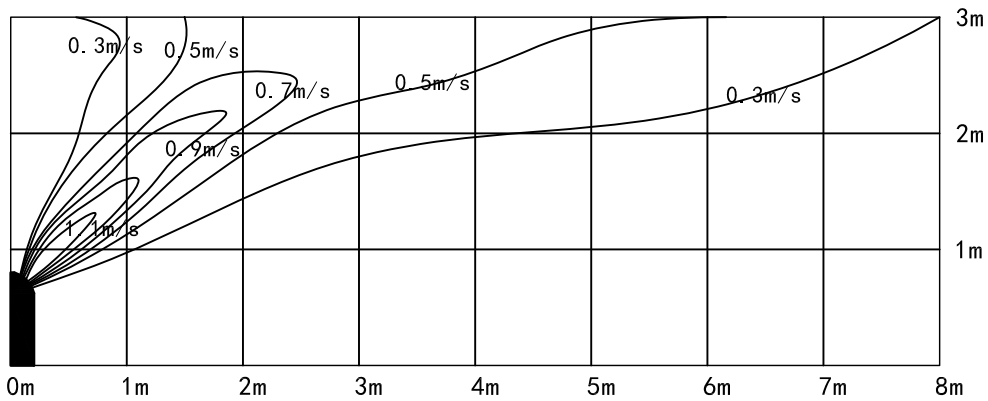

8) Floor install/Heating/ Air Temperature Distribution

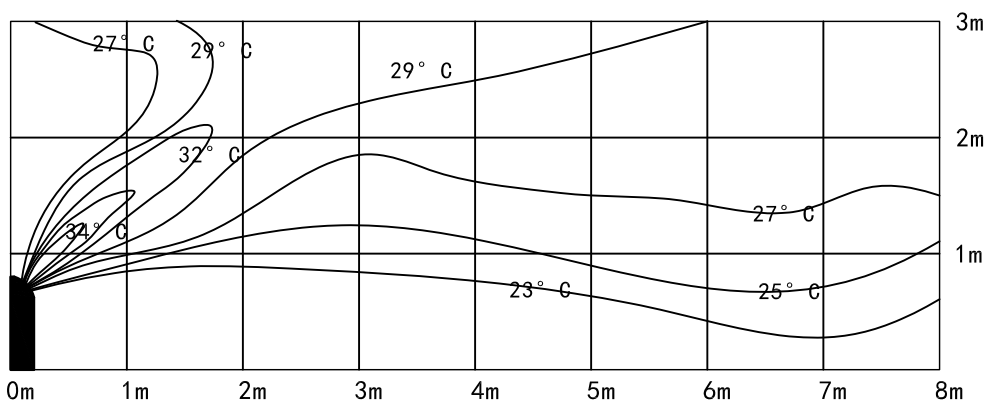

7. AIR FLOW DISTRIBUTION

60K

1) Ceiling install/Cooling/ Air Velocity Distribution

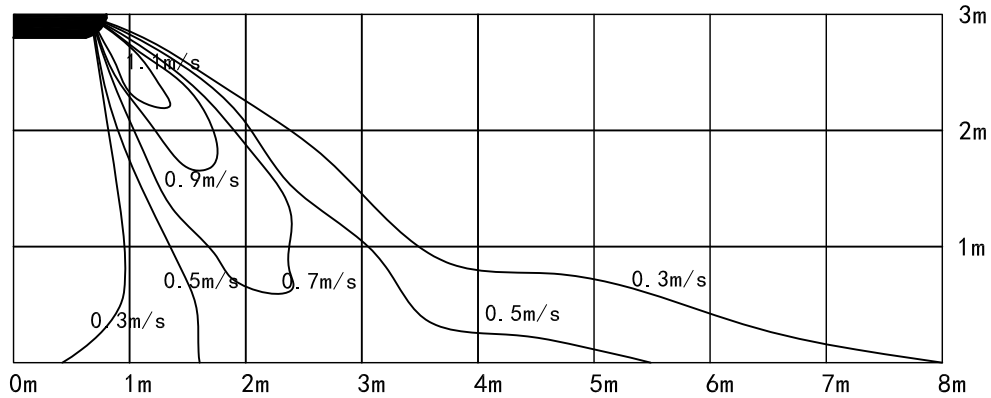

2) Ceiling install/Cooling/ Air Temperature Distribution

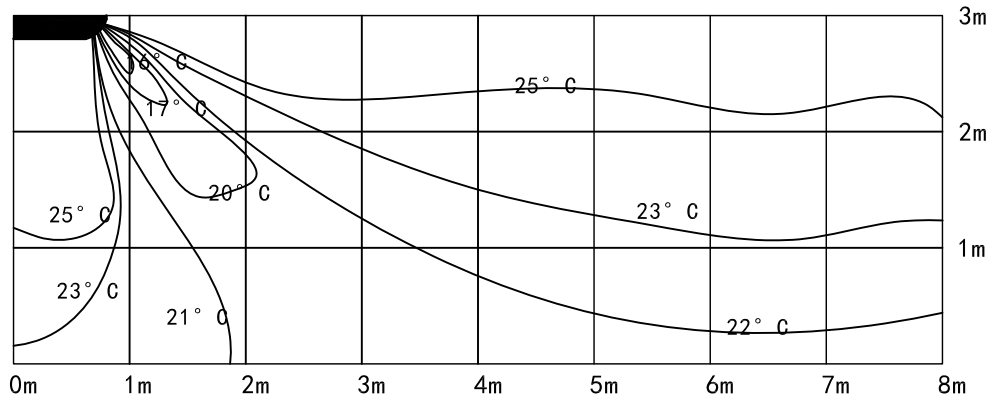

3) Ceiling install/Heating/ Air Velocity Distribution

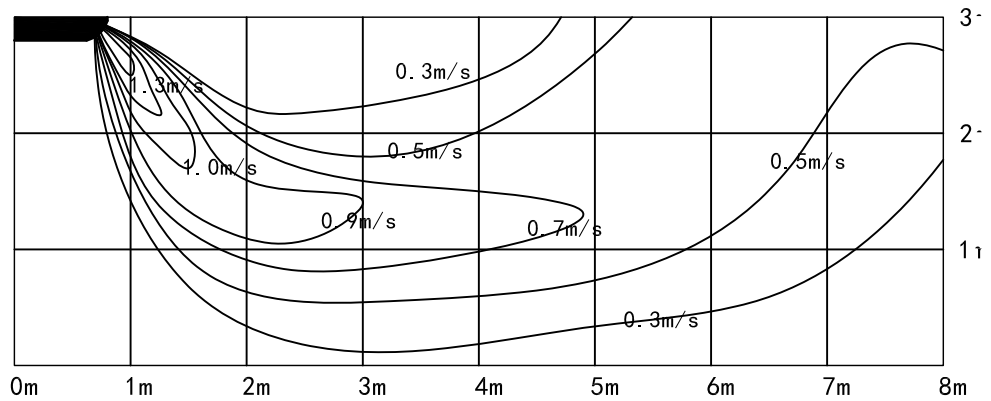

4) Ceiling install/Heating/ Air Temperature Distribution

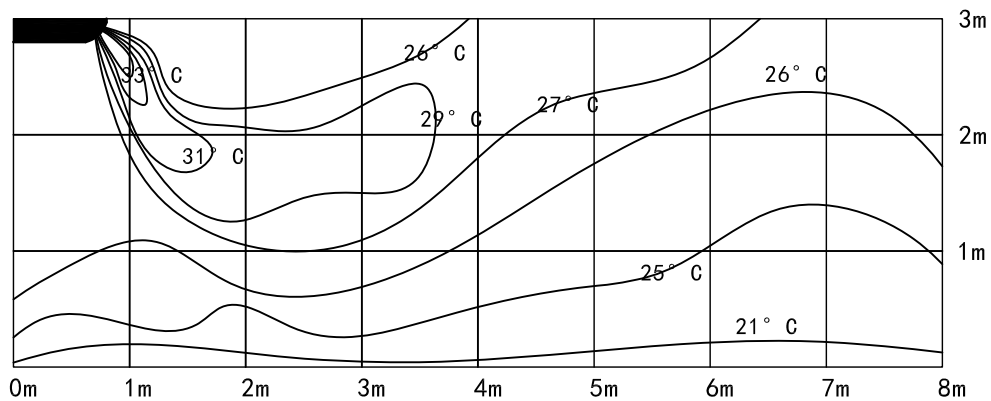

7. AIR FLOW DISTRIBUTION

5) Floor install/Cooling/ Air Velocity Distribution

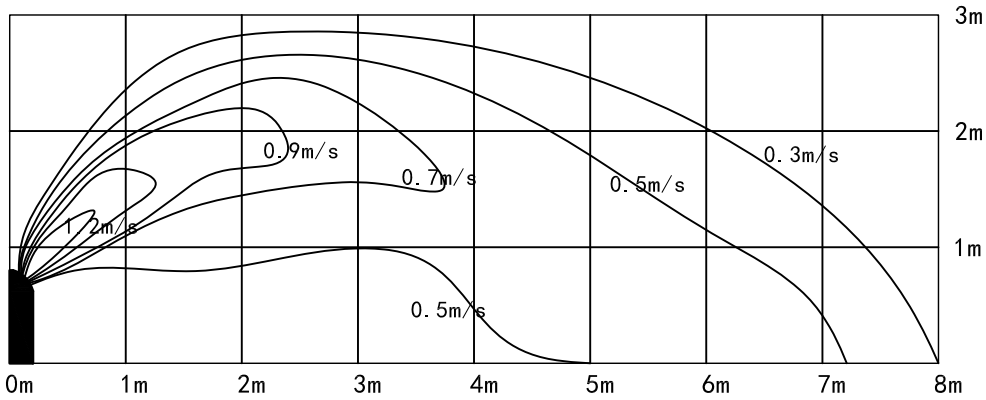

6) Floor install/Cooling/ Air Temperature Distribution

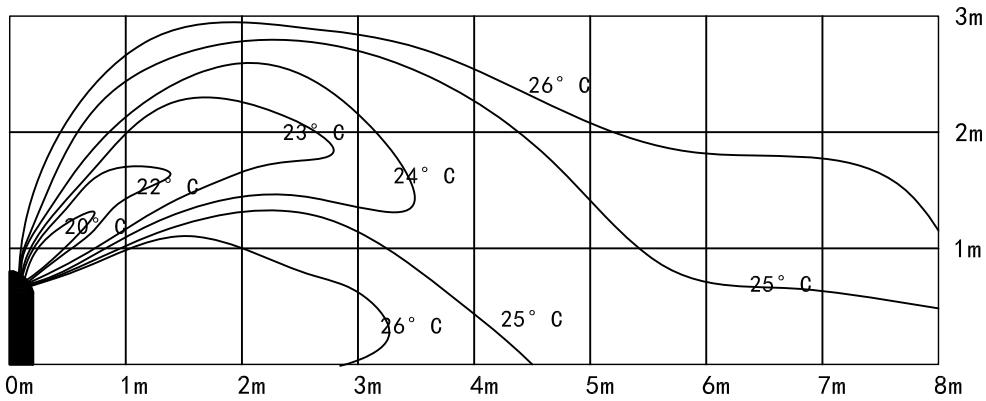

7) Floor install/Heating/ Air Velocity Distribution

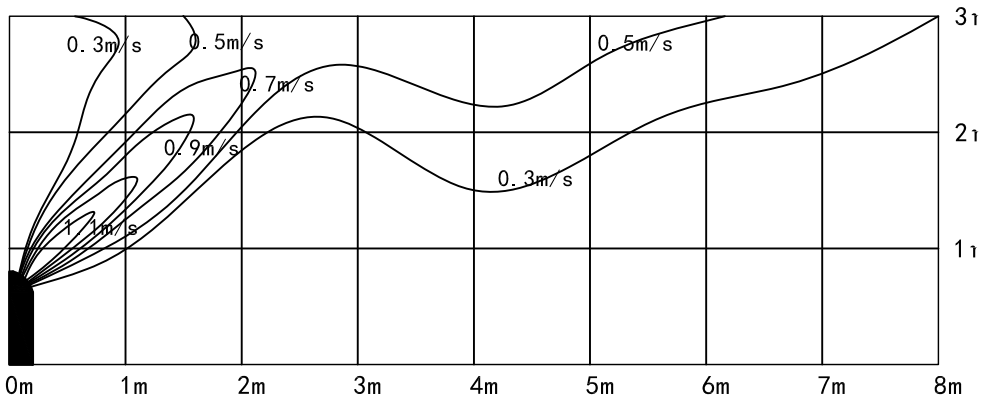

8) Floor install/Heating/ Air Temperature Distribution

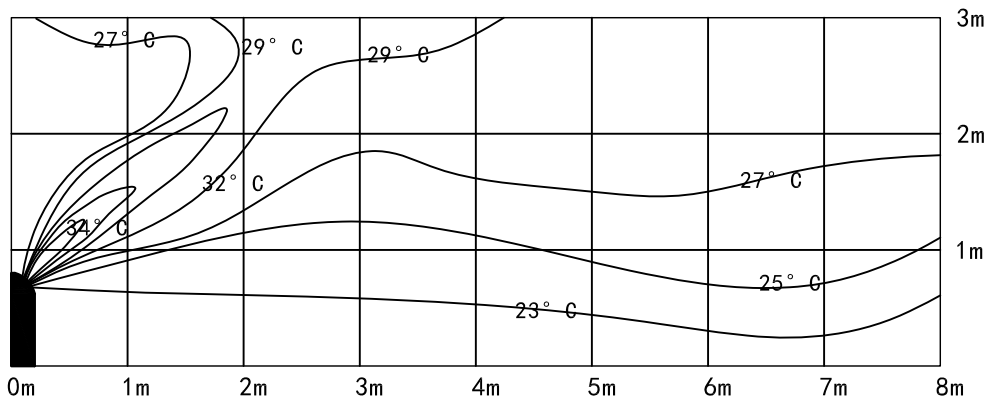

8. ESP (EXTERNAL STATIC PRESSURE) CHART (DUCT TYPE)

8. ESP (External static pressure) chart (Duct type)

9K

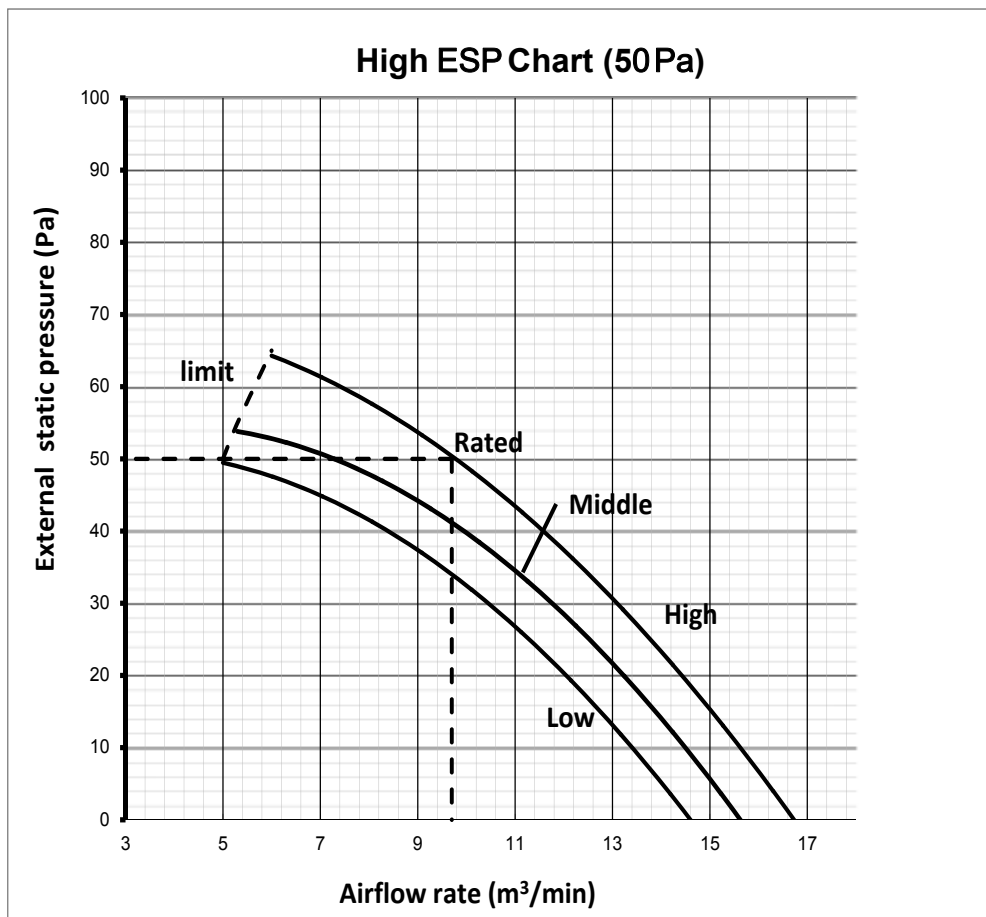
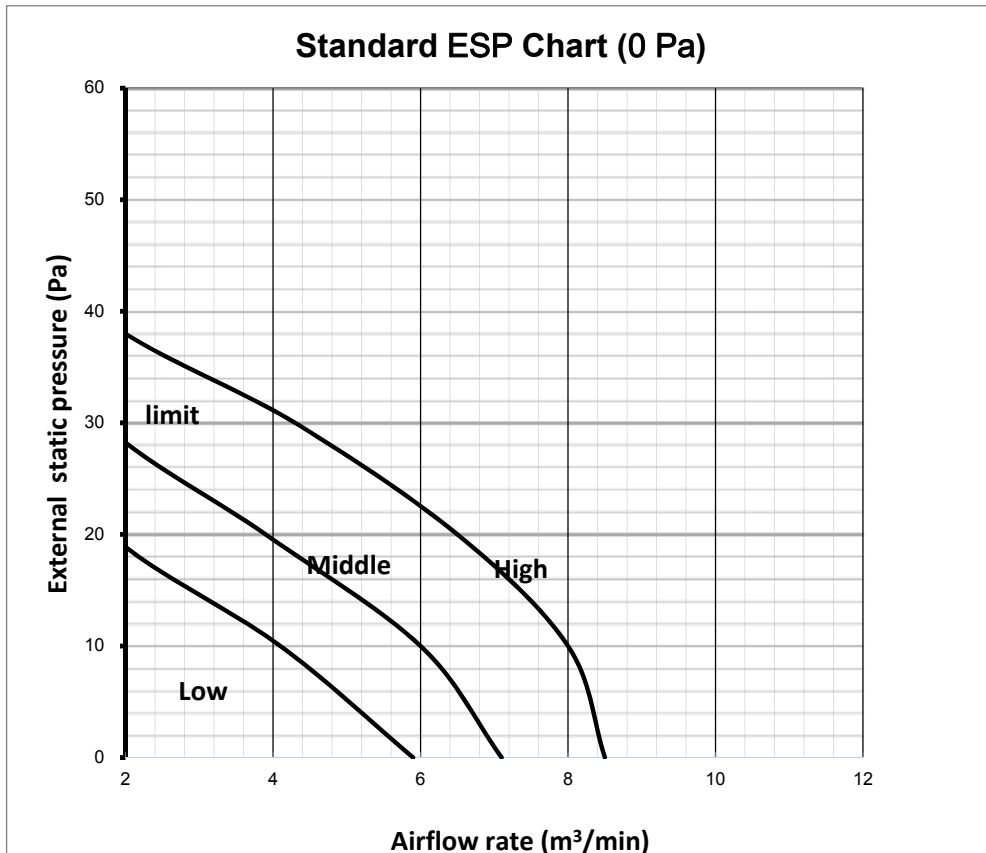

8. ESP (EXTERNAL STATIC PRESSURE) CHART (DUCT TYPE)

12K

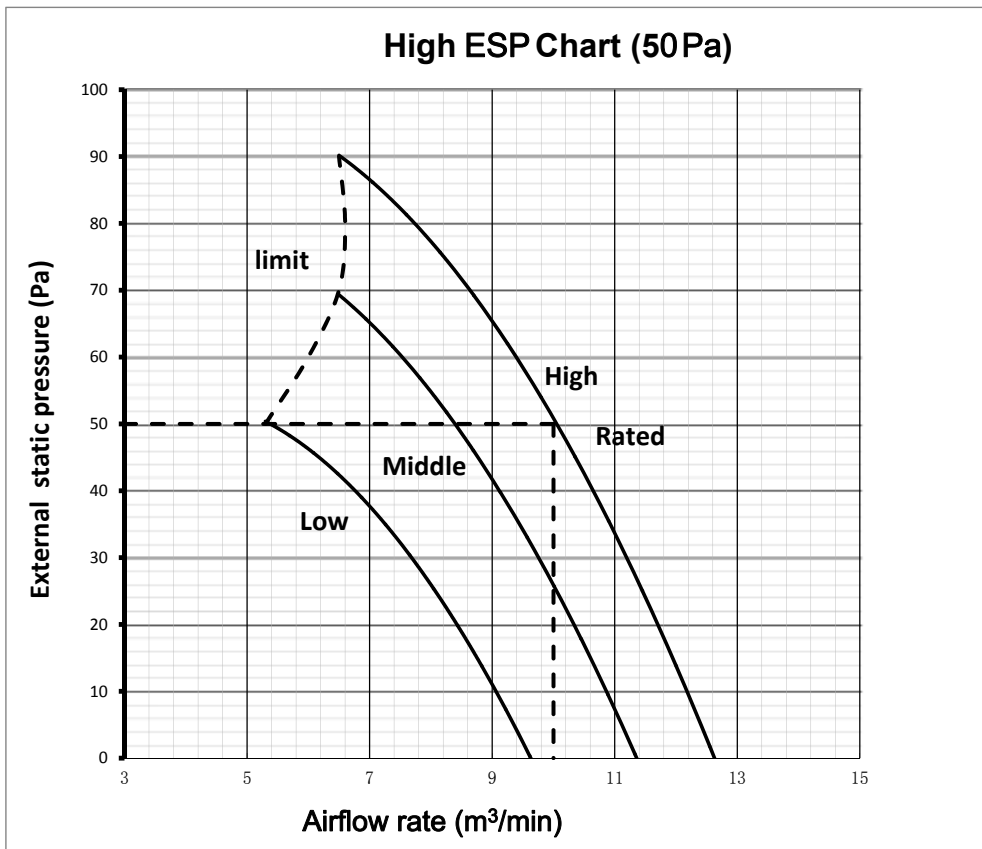
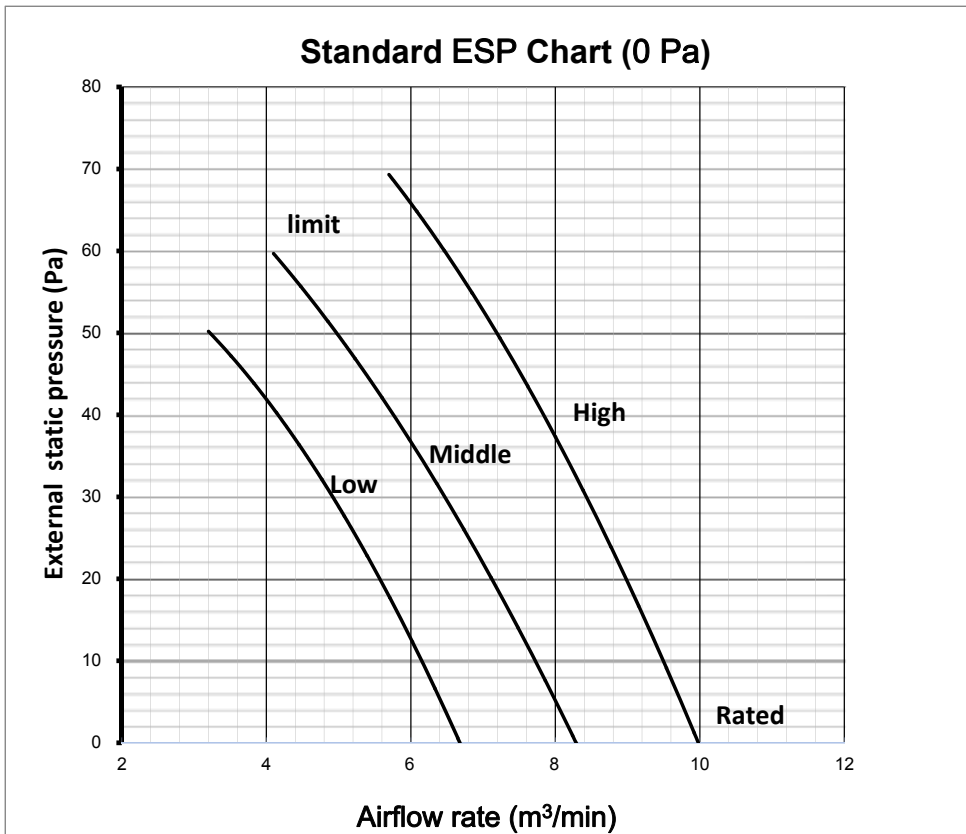

8. ESP (EXTERNAL STATIC PRESSURE) CHART (DUCT TYPE)

18K

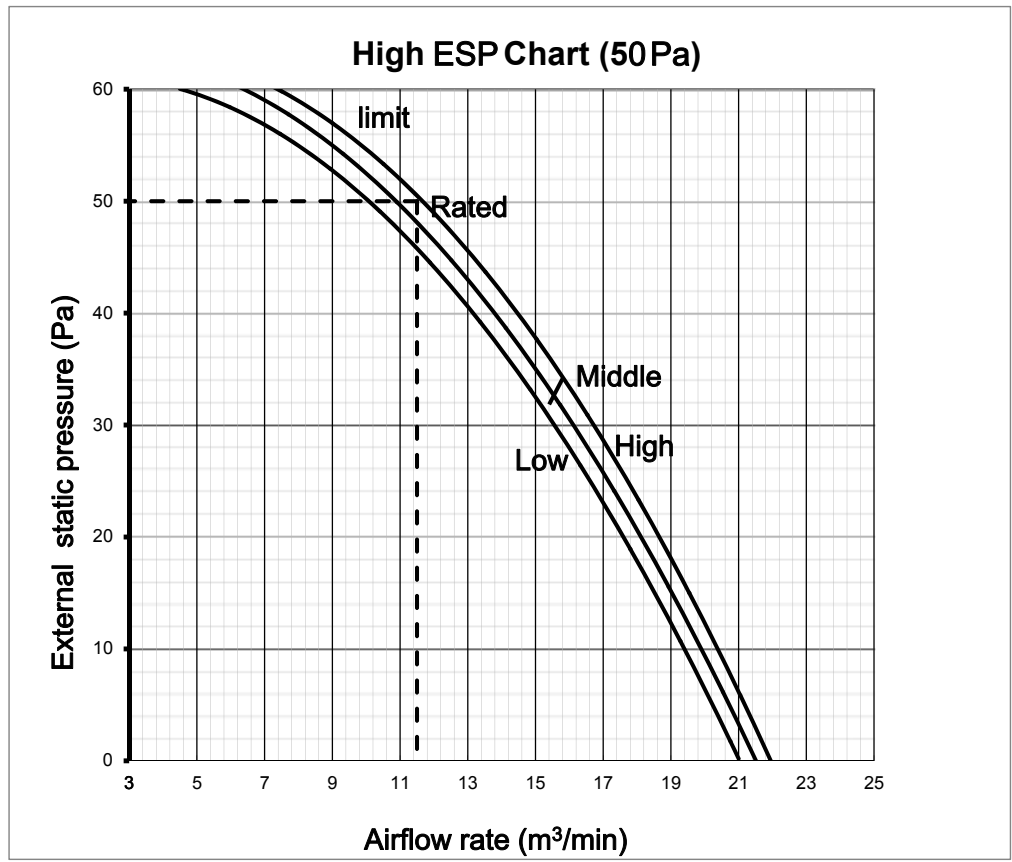
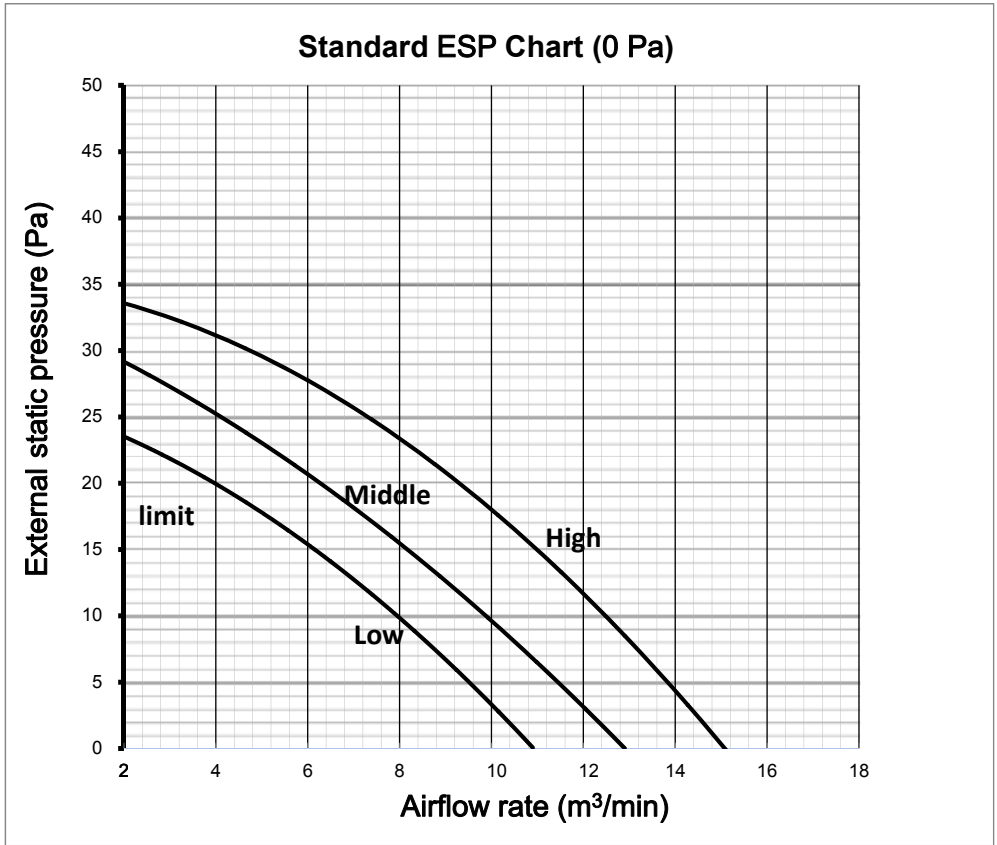

8. ESP (EXTERNAL STATIC PRESSURE) CHART (DUCT TYPE)

24K

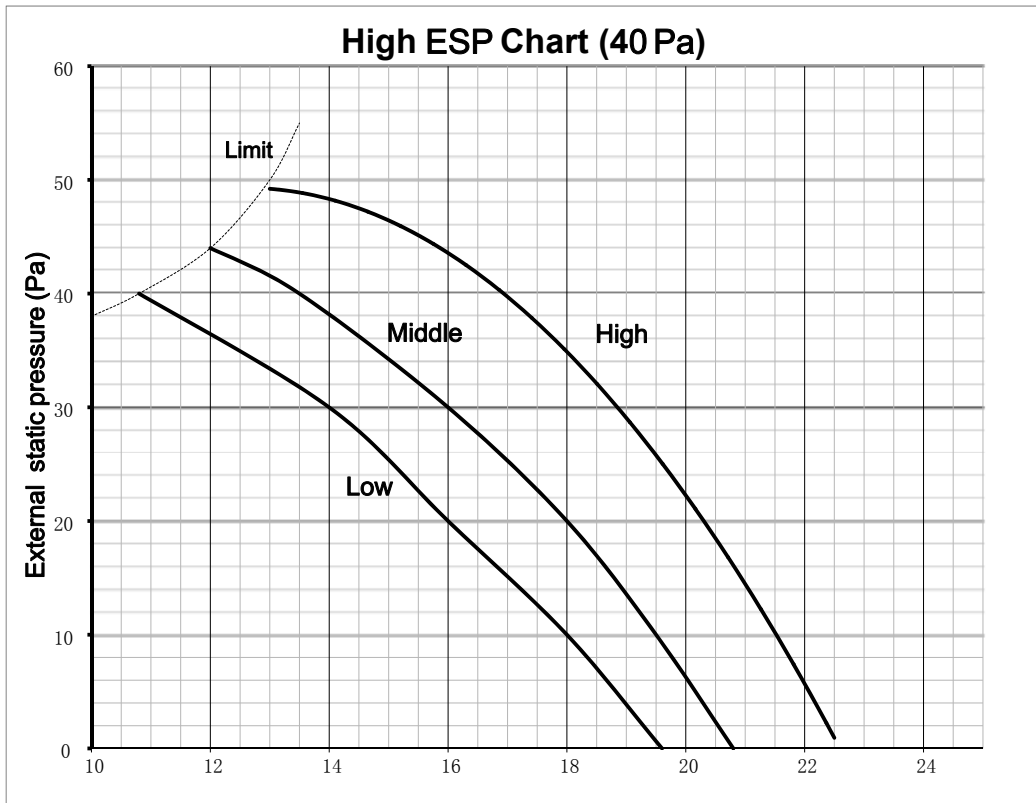
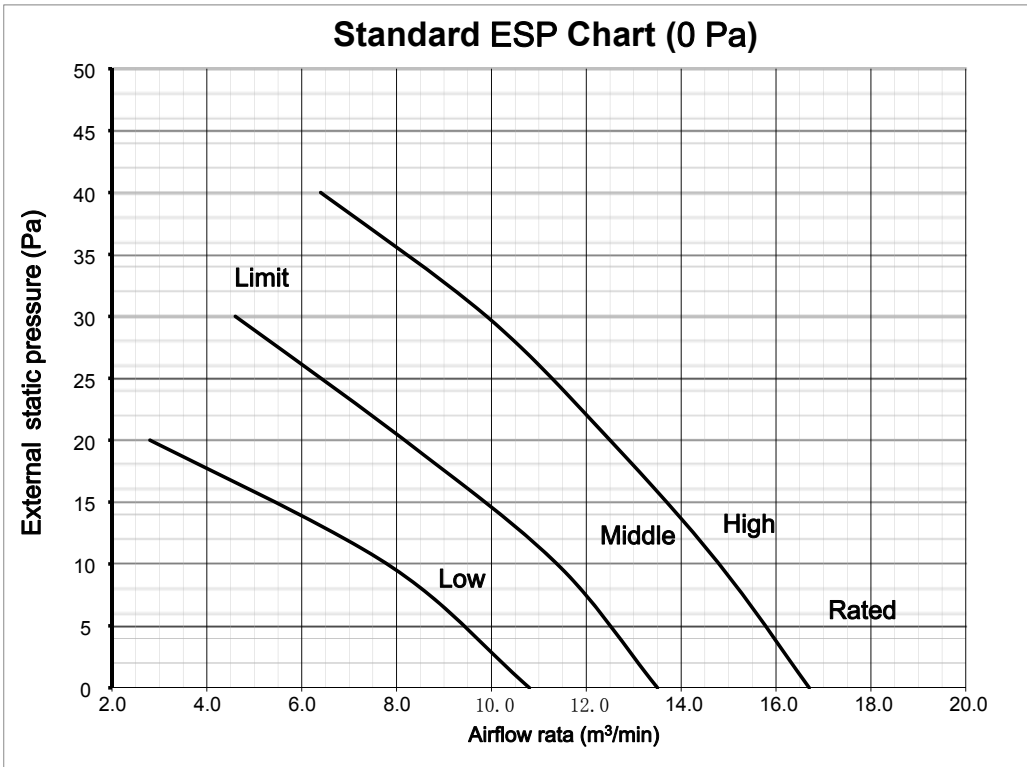

8. ESP (EXTERNAL STATIC PRESSURE) CHART (DUCT TYPE)

30K

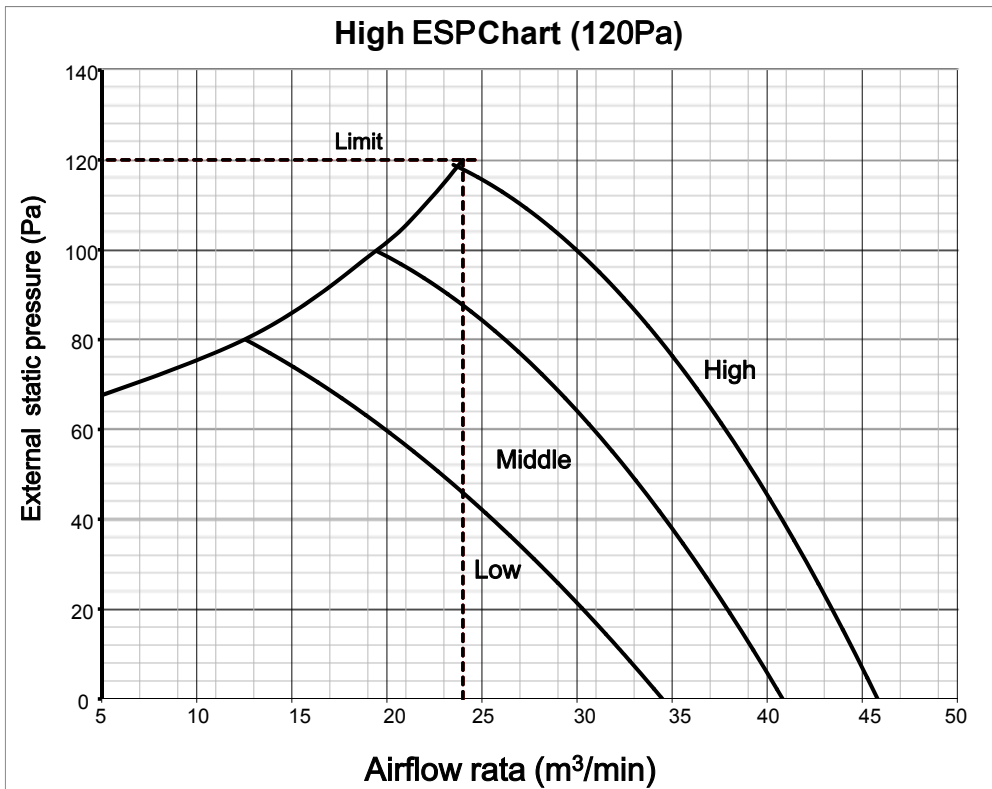
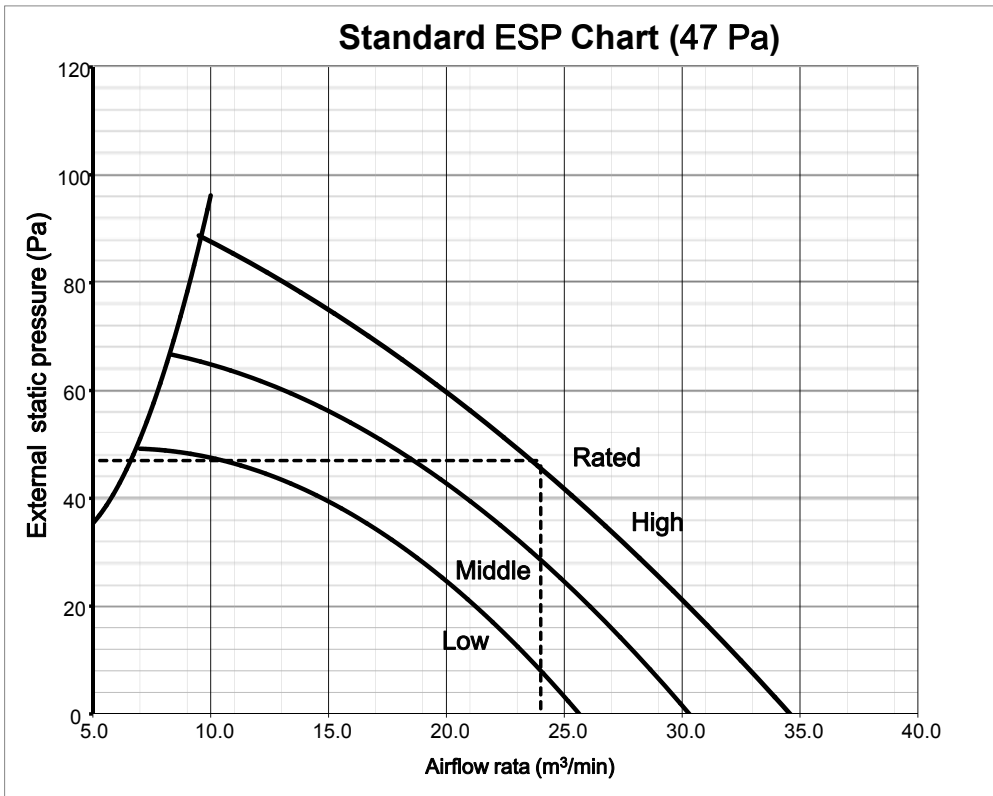

8. ESP (EXTERNAL STATIC PRESSURE) CHART (DUCT TYPE)

36K

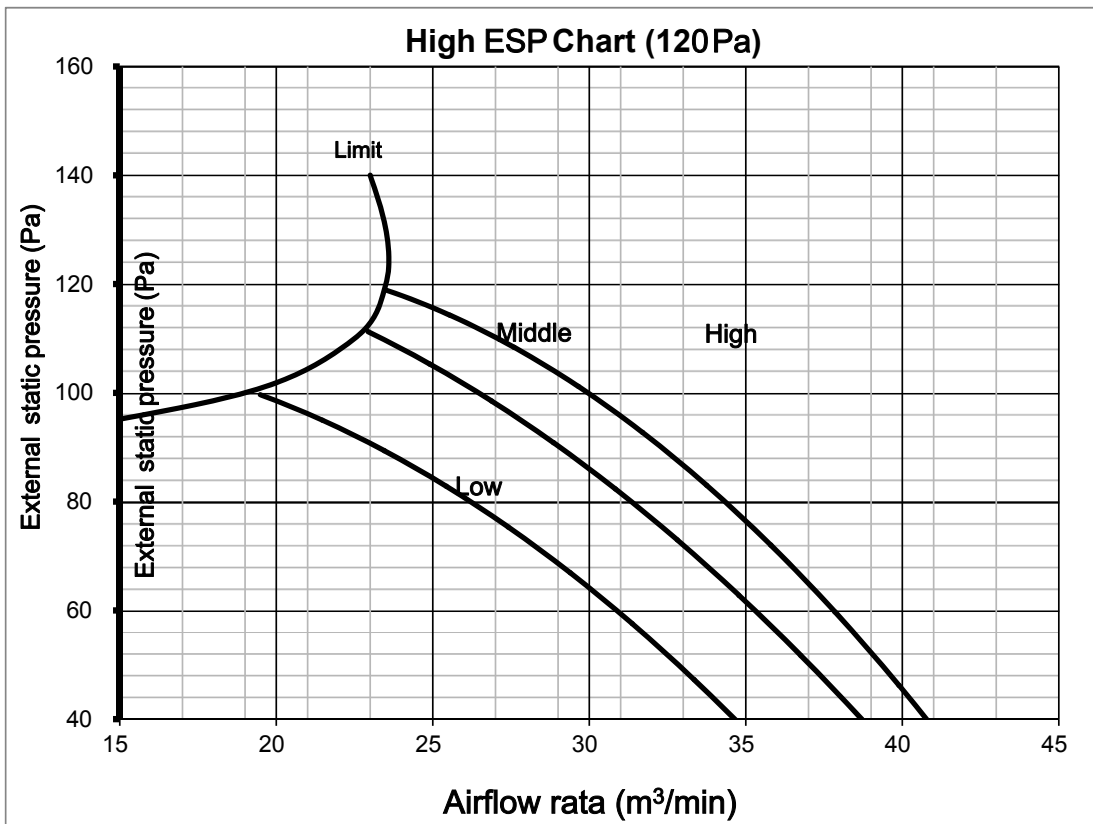
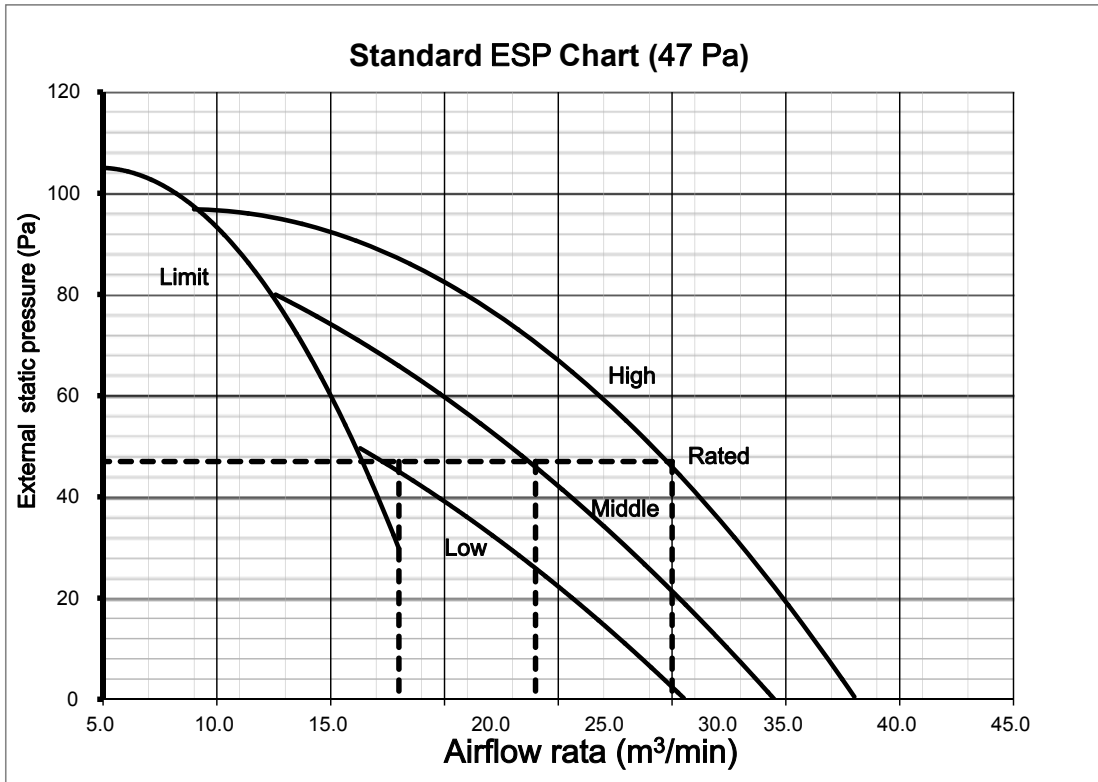

8. ESP (EXTERNAL STATIC PRESSURE) CHART (DUCT TYPE)

42K

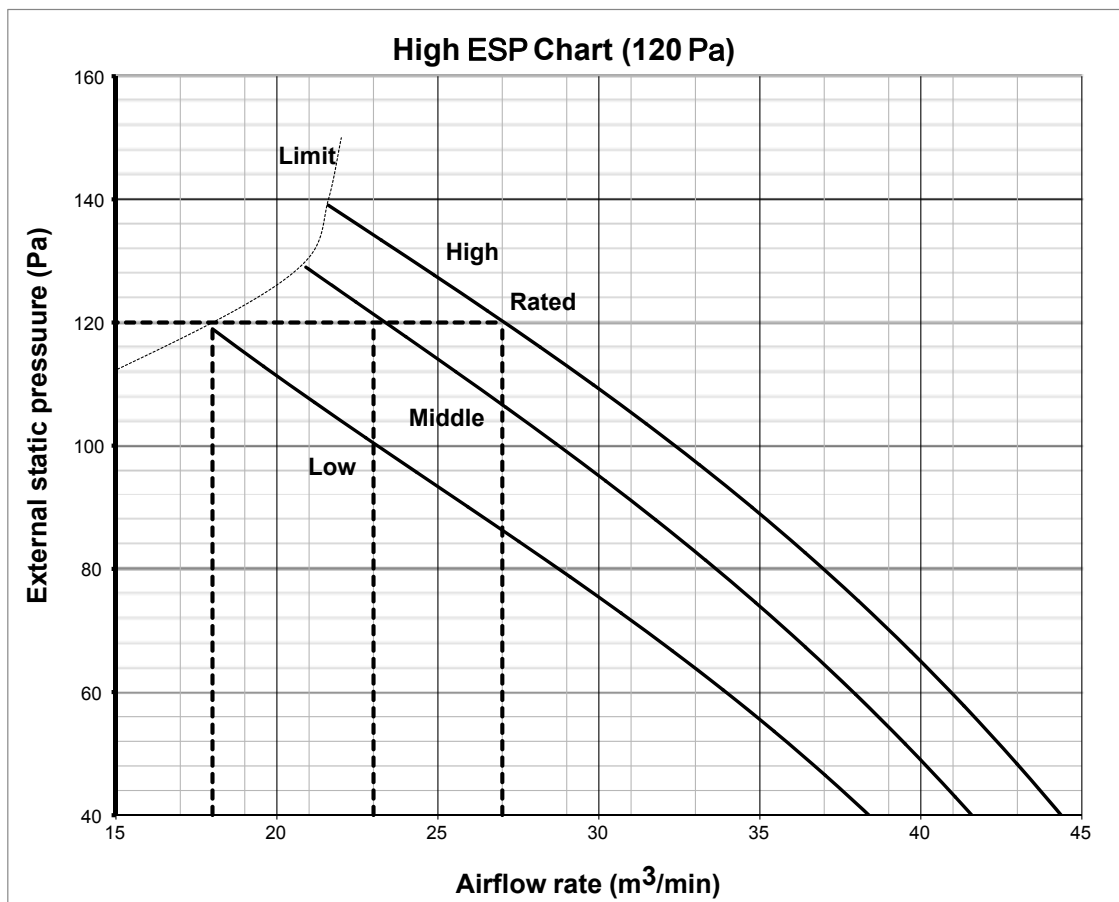
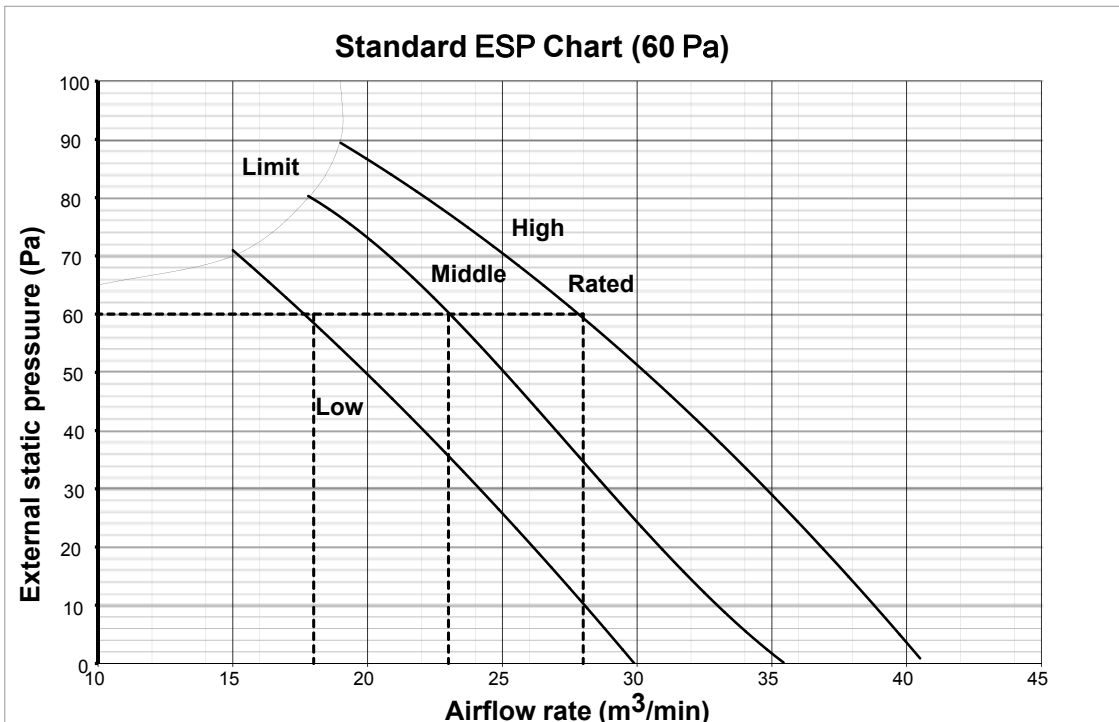

8. ESP (EXTERNAL STATIC PRESSURE) CHART (DUCT TYPE)

48K

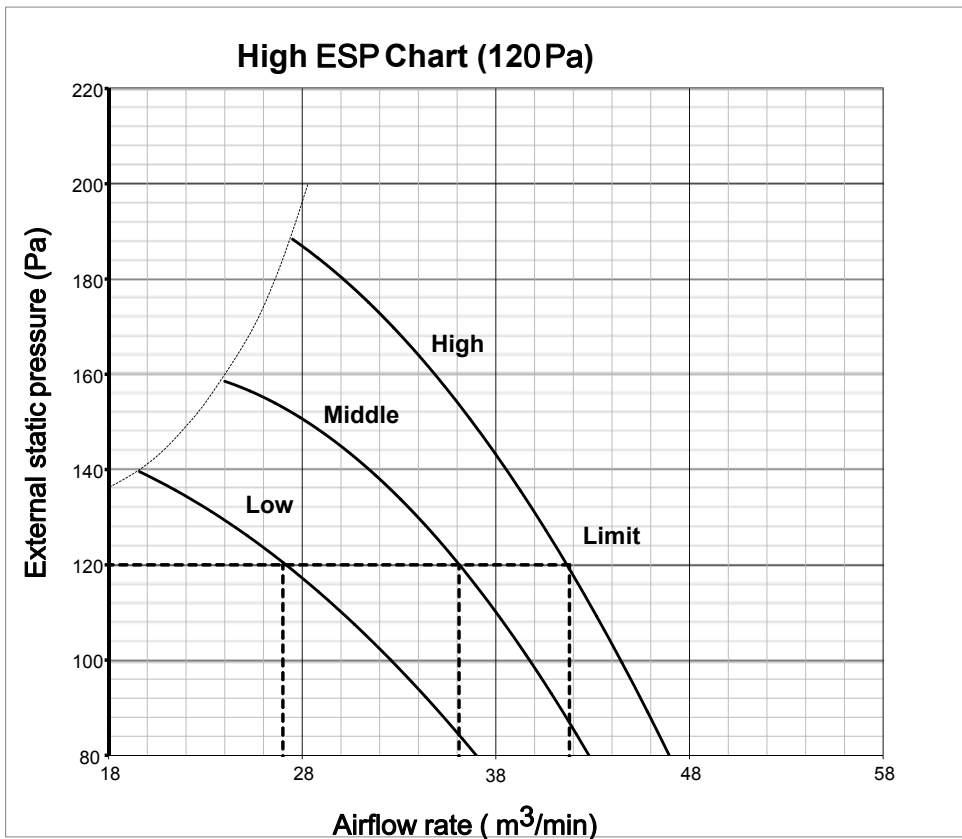
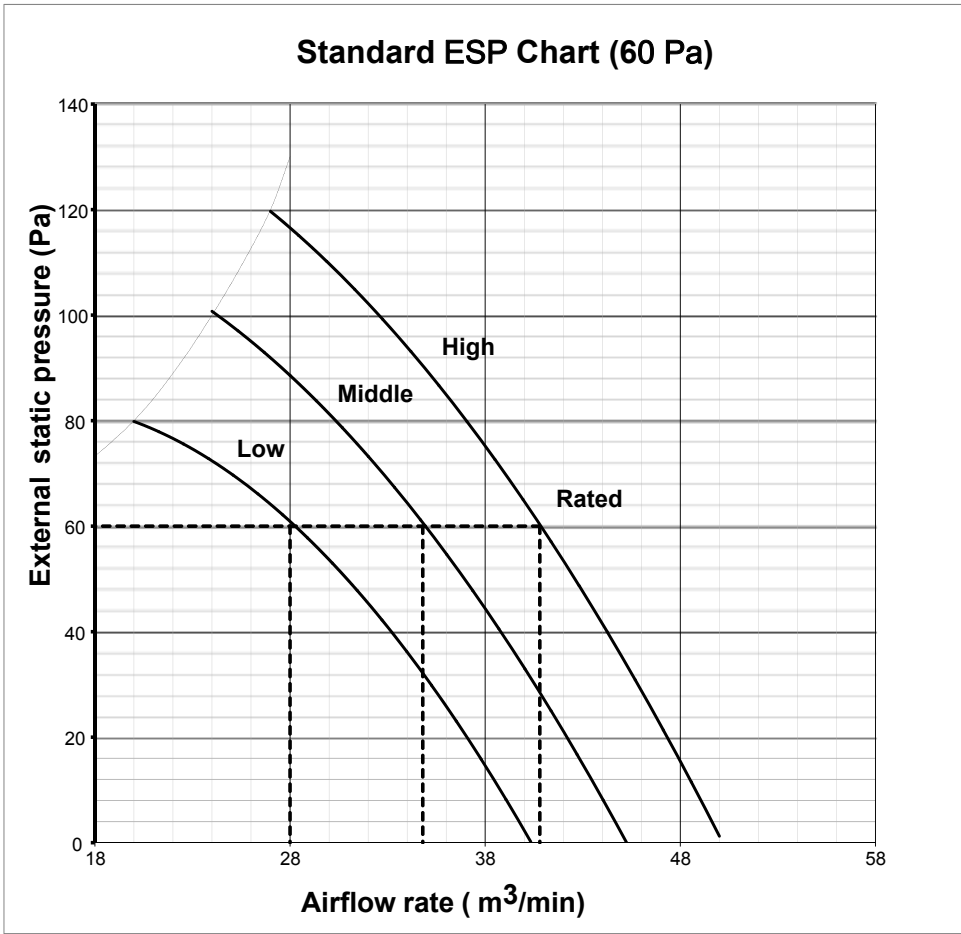

8. ESP (EXTERNAL STATIC PRESSURE) CHART (DUCT TYPE)

60K

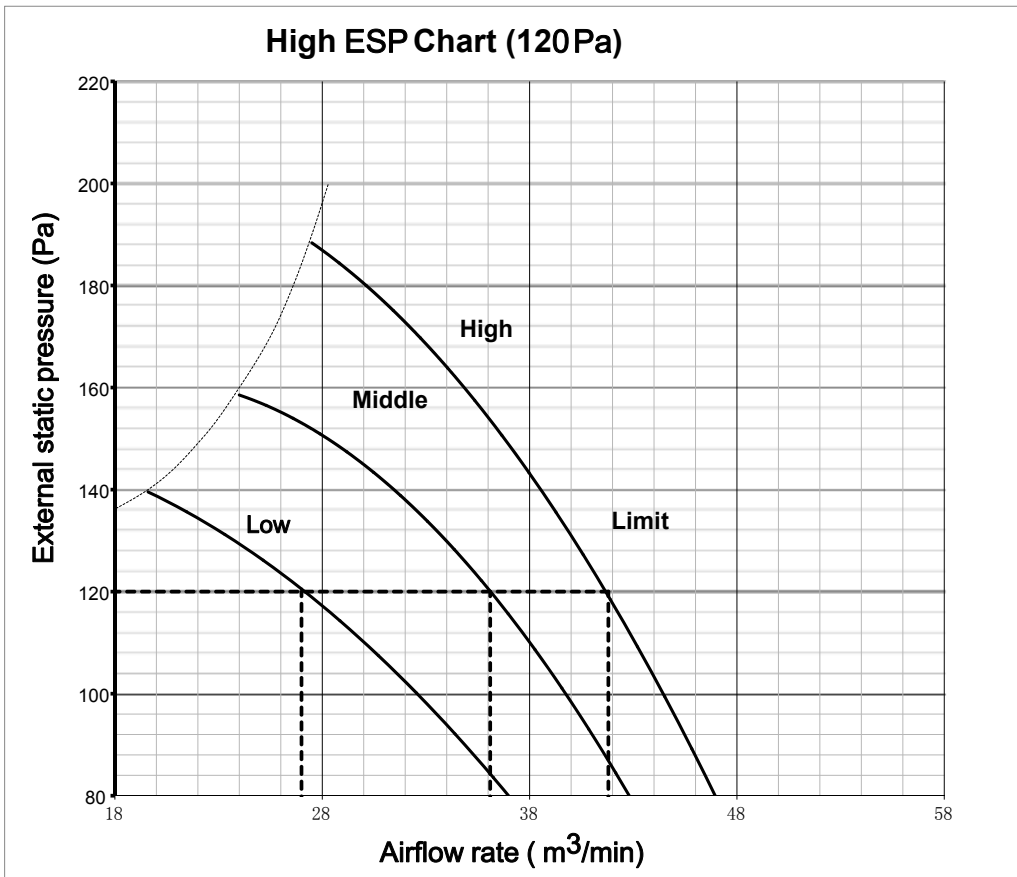
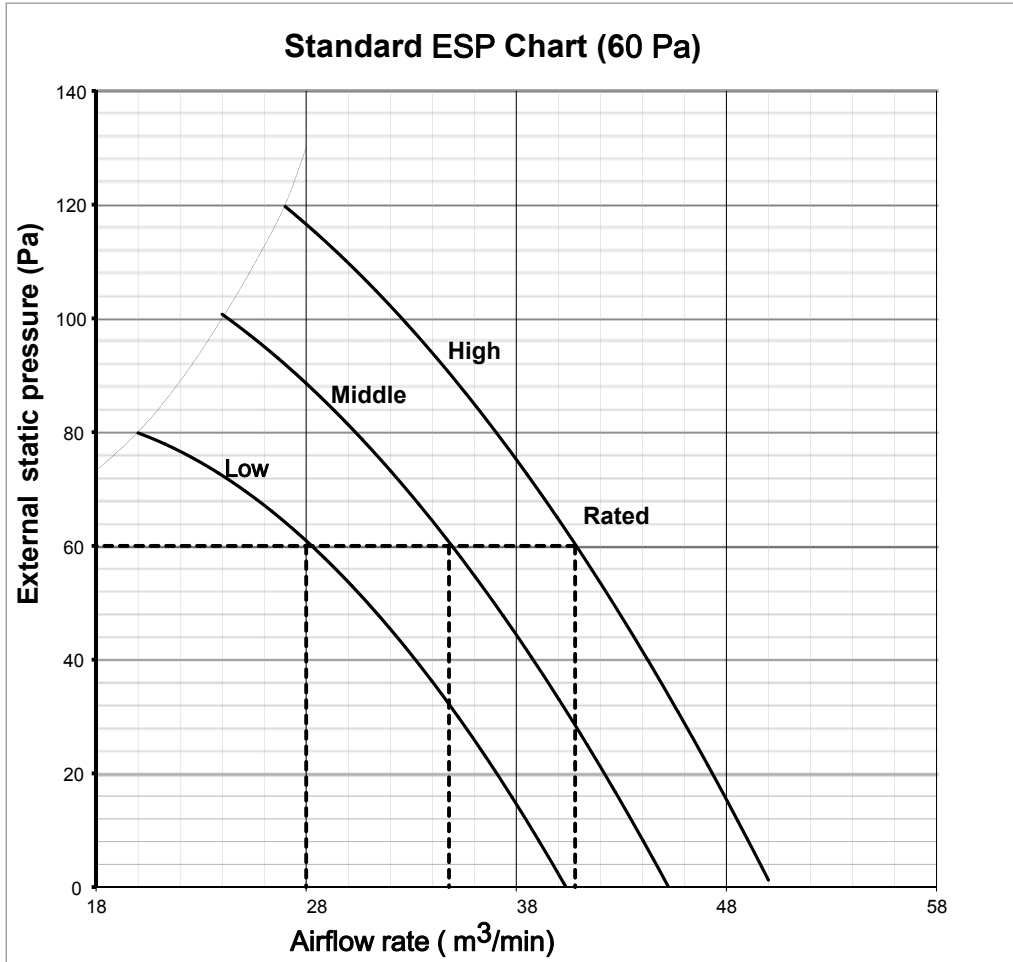

9. REFRIGERANT CYCLE

9. Refrigerant cycle

Indoor unit

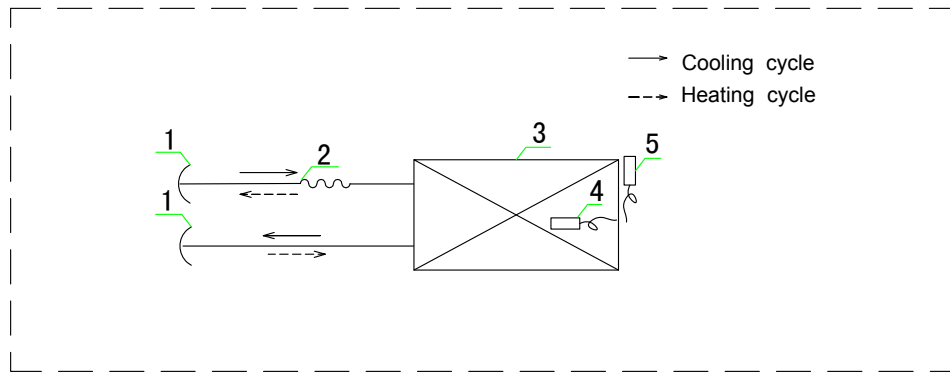

List of components			
1	Hexagon nut	4	Ambient temperature sensor
2	Split capillary	5	Coil temperature sensor
3	Indoor heat exchanger		

9. REFRIGERANT CYCLE

Outdoor unit

9K

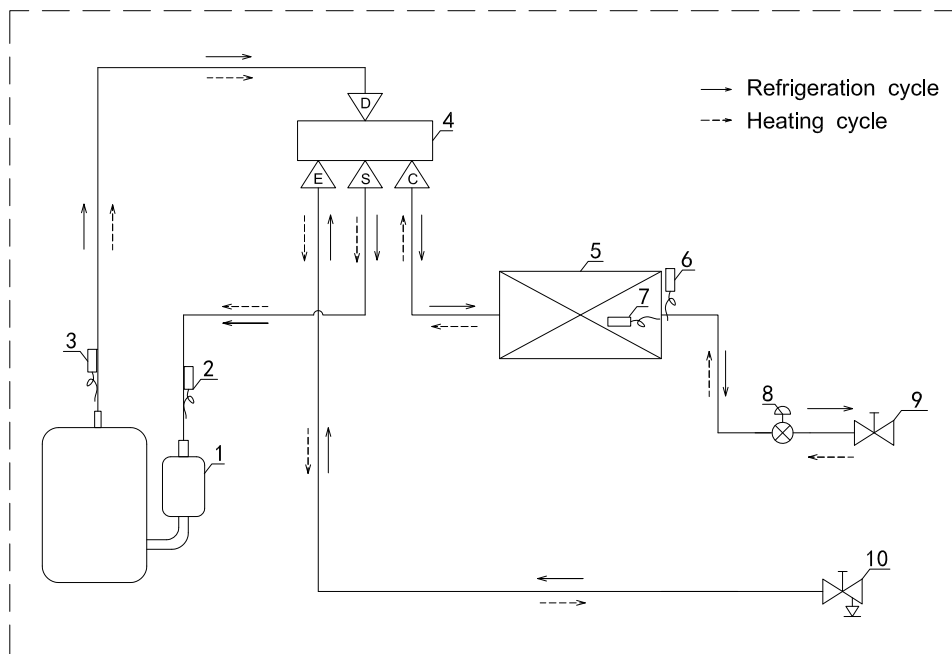

List of components

1	Compressor
2	Suction temperature sensor
3	Discharge temperature sensor
4	4-way valve
5	Outdoor heat exchanger
6	Coil temperature sensor
7	Ambient temperature sensor
8	Electronic expansion valve
9	Stop valve (Liquid)
10	Stop valve (Gas)

9. REFRIGERANT CYCLE

12K/18K/24K/30K

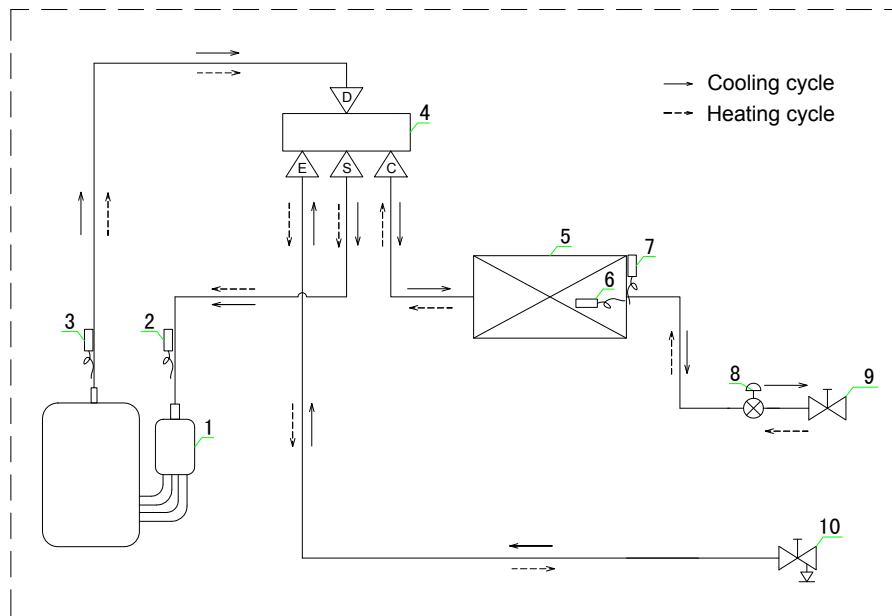

List of components	
1	Compressor
2	Suction temperature sensor
3	Discharge temperature sensor
4	4-way valve
5	Outdoor heat exchanger
6	Ambient temperature sensor
7	Coil temperature sensor
8	Electronic expansion valve
9	Stop valve (Liquid)
10	Stop valve (Gas)

9. REFRIGERANT CYCLE

36K

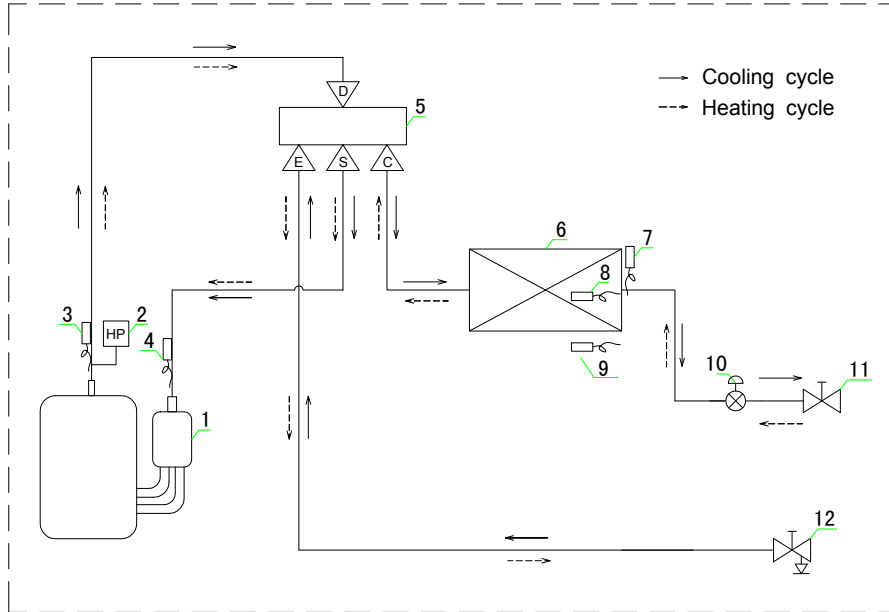

List of components

1	Compressor	7	Coil temperature sensor
2	High pressure switch	8	Defrost temperature sensor
3	Discharge temperature sensor	9	Ambient temperature sensor
4	Suction temperature sensor	10	Electronic expansion valve
5	4-Way valve	11	Stop valve (Liquid)
6	Outdoor heat exchanger	12	Stop valve (Gas)

9. REFRIGERANT CYCLE

42K

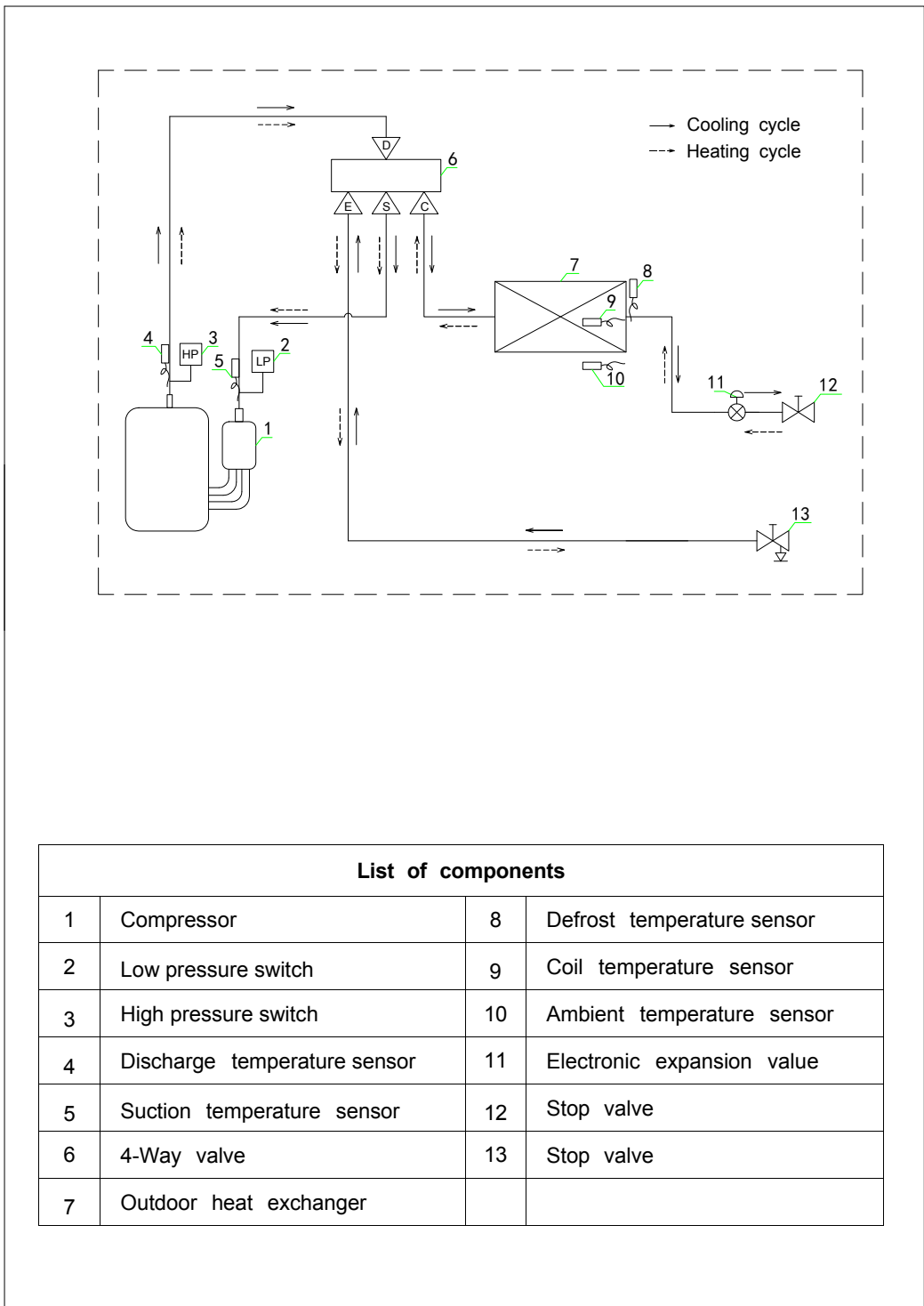

List of components			
1	Compressor	8	Defrost temperature sensor
2	Low pressure switch	9	Coil temperature sensor
3	High pressure switch	10	Ambient temperature sensor
4	Discharge temperature sensor	11	Electronic expansion valve
5	Suction temperature sensor	12	Stop valve
6	4-Way valve	13	Stop valve
7	Outdoor heat exchanger		

9. REFRIGERANT CYCLE

48K/60K

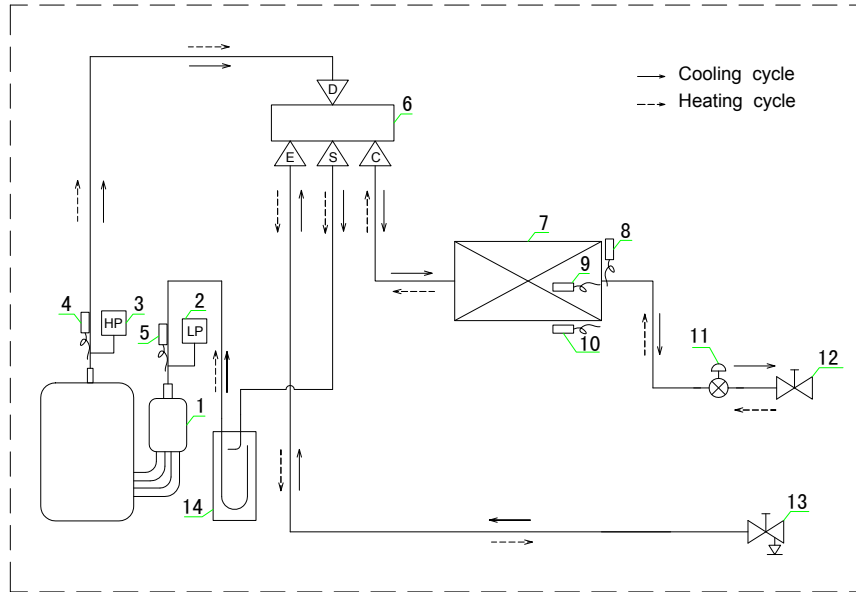

List of components

1	Compressor	8	Coil temperature sensor
2	Low pressure switch	9	Ambient temperature sensor
3	High pressure switch	10	Defrost temperature sensor
4	Discharge temperature sensor	11	Electronic expansion valve
5	Suction temperature sensor	12	Stop valve
6	4-Way valve	13	Stop valve
7	Outdoor heat exchanger	14	Gas-liquid separator

10. FRESH AIR INTAKE FUNCTION

10. Fresh air intake function

Duct (9K~36K)

Indoor unit can take fresh air from the reserved fresh air intake, the size of the fresh air intake hole is $\Phi 65\text{mm}$ (9K~24K), $\Phi 125\text{mm}$ (36K).

Please follow the steps below when needed.

- 1) Cut off the reserved metal circular hole on the base board.
- 2) Connect air duct with the fresh air intake.

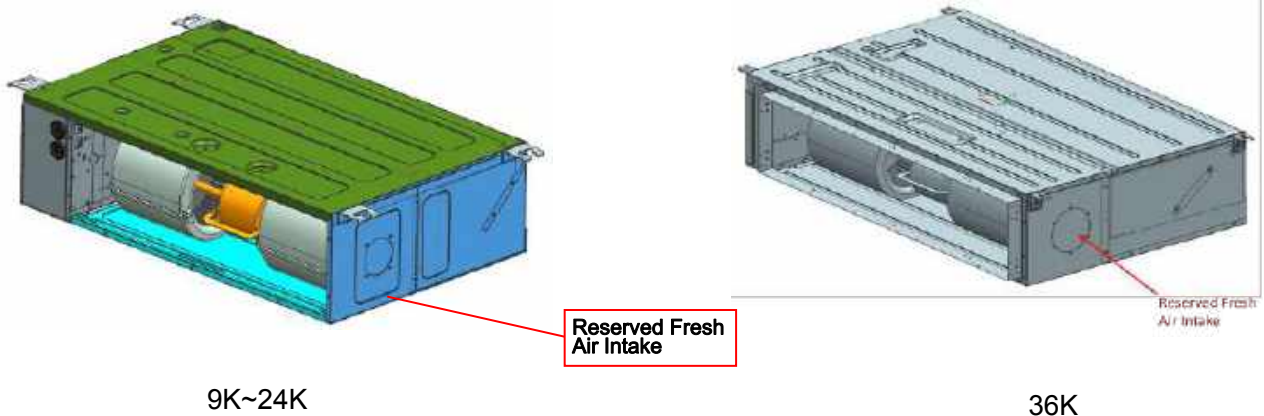

Cassette

Indoor unit can take fresh air from the reserved fresh air intake, the size of the fresh air intake hole is $83\times 43\text{(mm)}$ (9K~18K), $75\times 53\text{(mm)}$ (24K~60K).

Please follow the steps below when needed.

- 1) Cut off the reserved metal rectangular hole on the base board.
- 2) Cut off the foam material on the a rectangular hole.
- 3) Connect air duct with the fresh air intake.

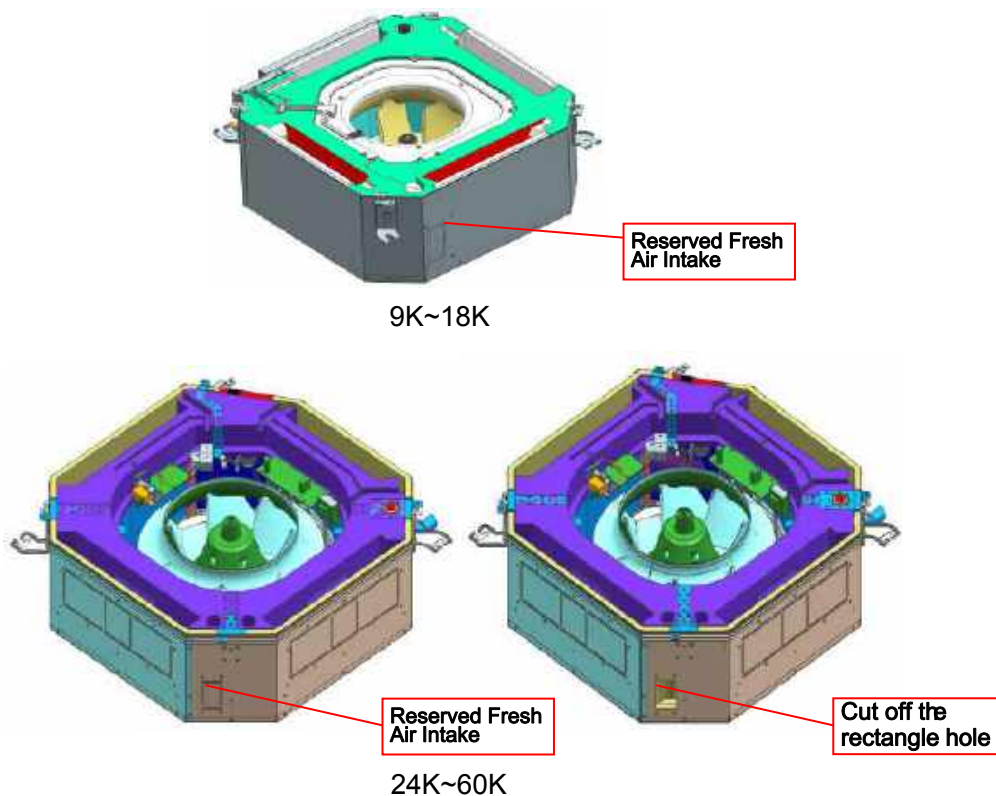

10. FRESH AIR INTAKE FUNCTION

Ceiling & Floor

The floor ceiling indoor units are provided with fresh air function. Indoor unit can take the fresh air from the reserved fresh air intake, the size of the fresh air intake hole is $\Phi 50(\text{mm})$. Please follow the steps below when needed.

- 1) Cut off the reserved metal circular hole on the base board or rear board according to installation location.
- 2) Connect air duct with the fresh air intake.

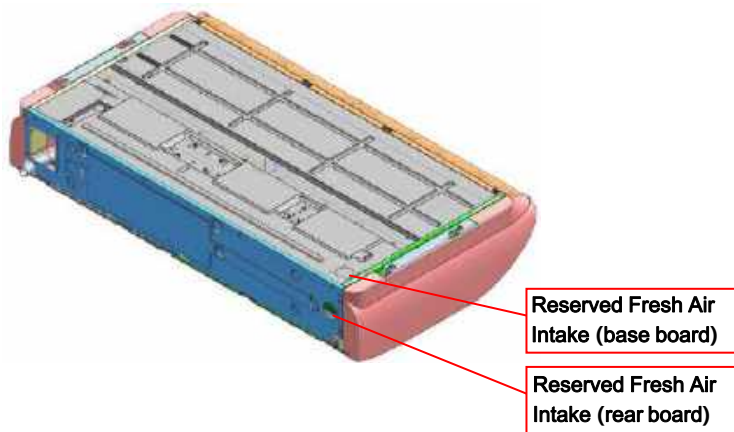

Console

All of the console indoor units are provided with fresh air function. It is possible to inhale fresh air to indoor unit from the reserved fresh air intake, the size of the fresh air intake is $\phi 40(\text{mm})$.

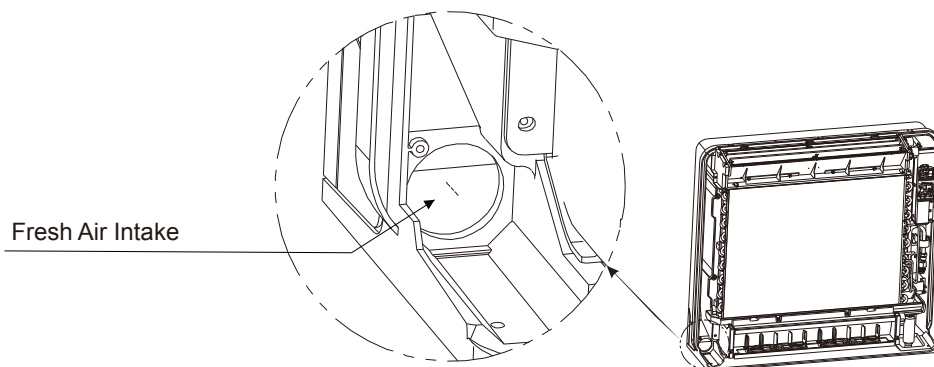

11. WIRING DIAGRAM

11. Wiring diagram

11.1 Electrical wiring diagram

Indoor unit

Duct type (9K~24K)

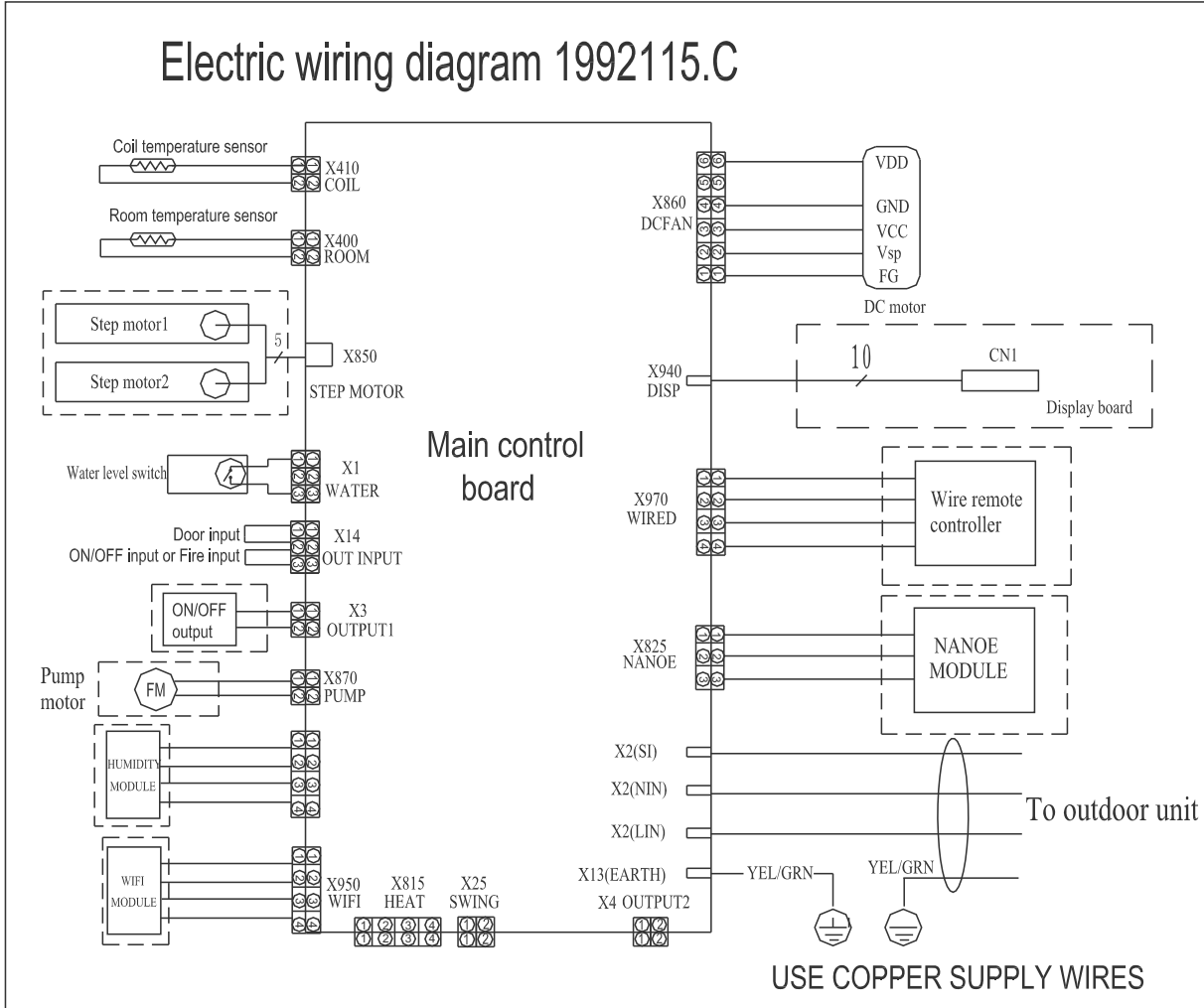

Remark:

Dashed parts are not available in some models.

Details see the table below.

	Indoor units model	Step motor	Pump motor	Humidity	WIFI Module	NANOE Module	Display board	Wired remote controller	ON/OFF output
Duct	9K~24K							●	●

●--available part

11. WIRING DIAGRAM

Duct type(30K~60K)

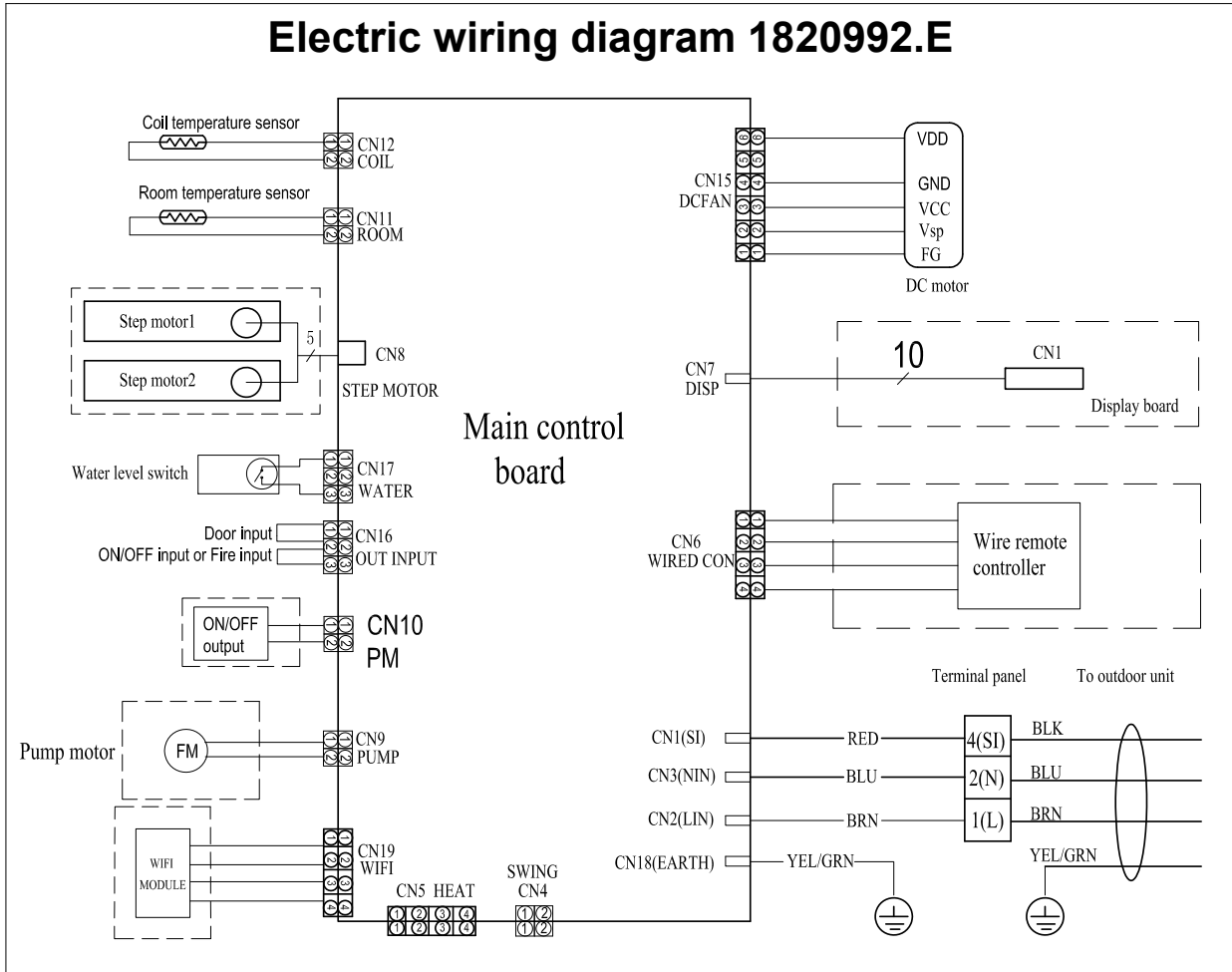

Remark:

Dashed parts are not available in some models.
Details see the table below.

	Indoor units model	Step motor	Pump motor	WIFI module	Display board	Wire remote controller	ON/OFF output
Duct	30K~60K					●	●

●--available part

11. WIRING DIAGRAM

Cassette type

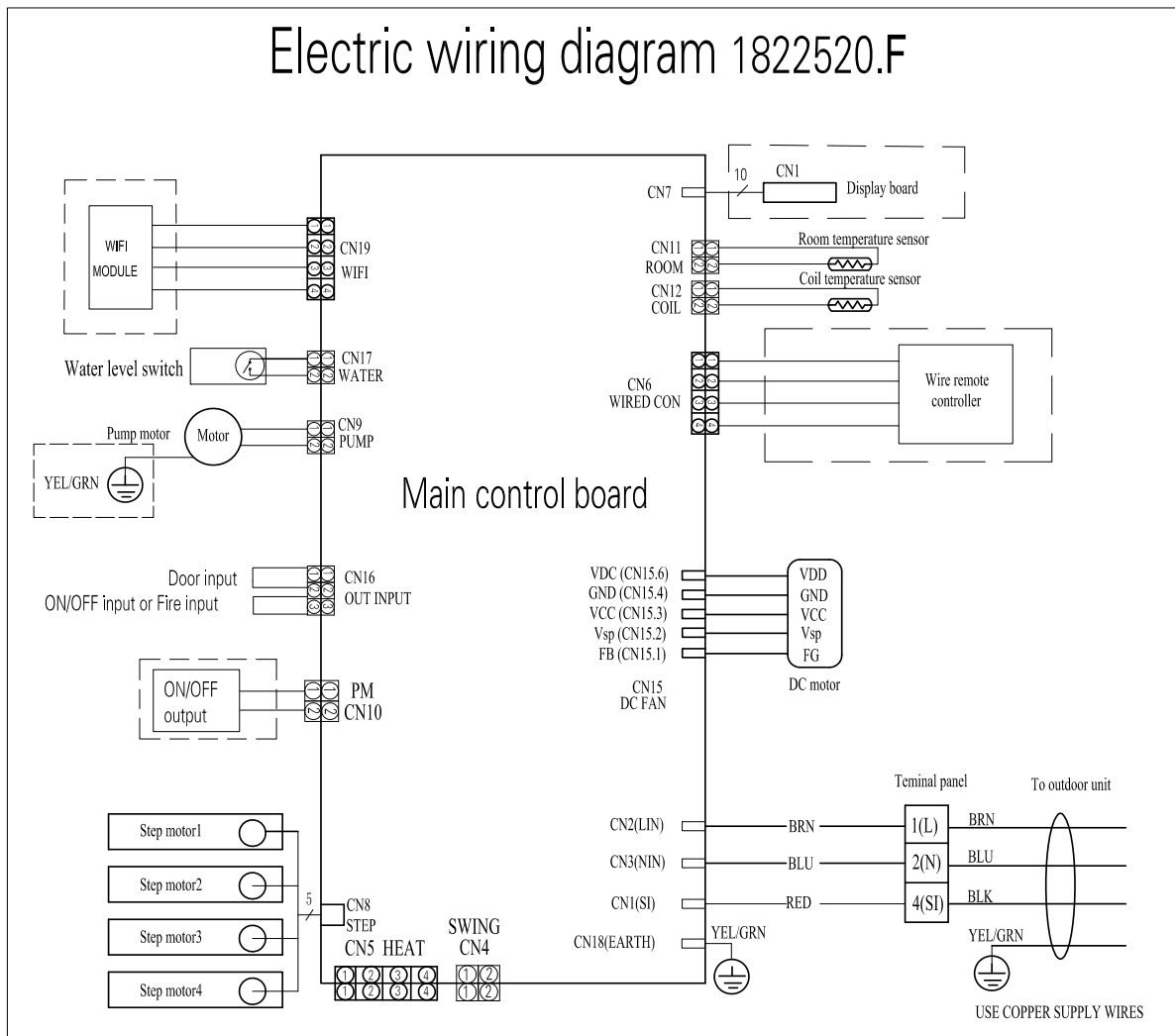

Remark:

Dashed parts are not available in some models.
Details see the table below.

	Indoor units model	Step motor	Pump motor	WiFi module	Display board	Wire remote controller	ON/OFF output
Cassette	9K~60K	●	●		●		●

●--available part

11. WIRING DIAGRAM

Ceiling & Floor type (18K~36K)

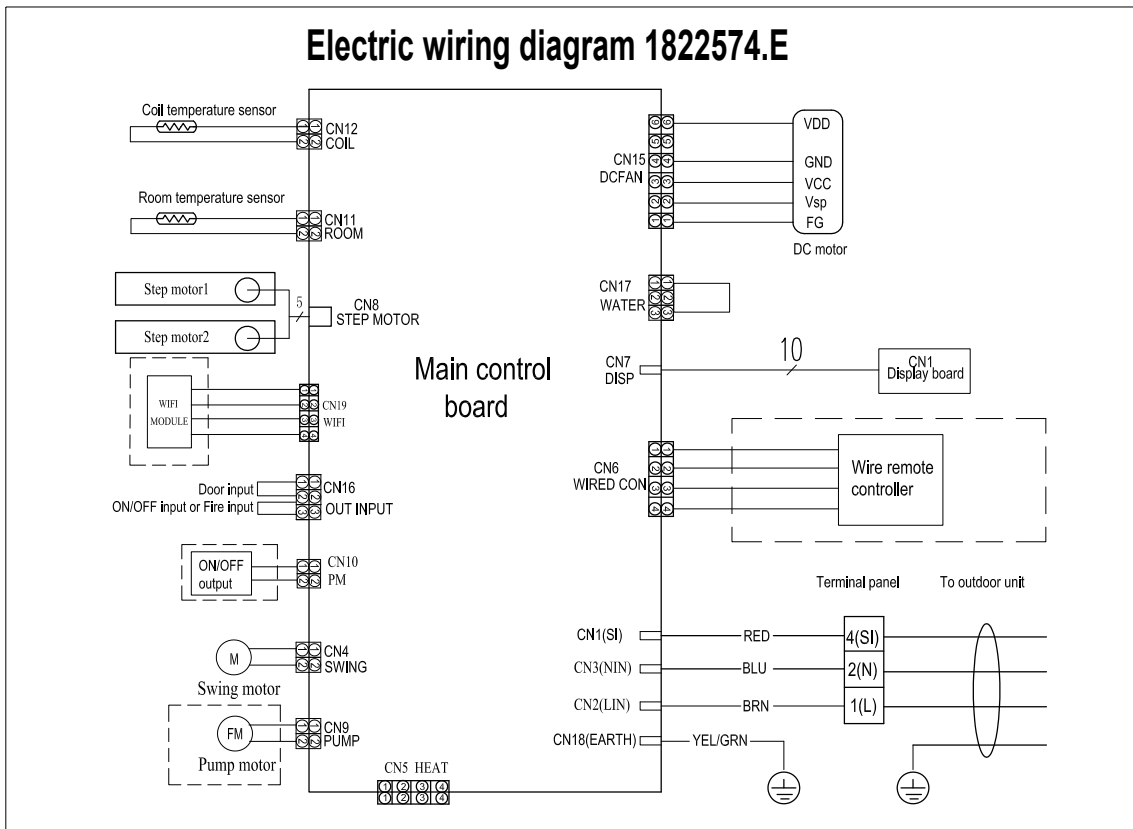

Remark:
Dashed parts are not available in some models.
Details see the table below.

	Indoor units model	Step motor	Pump motor	WIFI module	Display board	Wire remote controller	ON/OFF output
Ceiling & Floor	24K/36K	●			●		●

●--available part

11. WIRING DIAGRAM

Ceiling & Floor type (42K~60K)

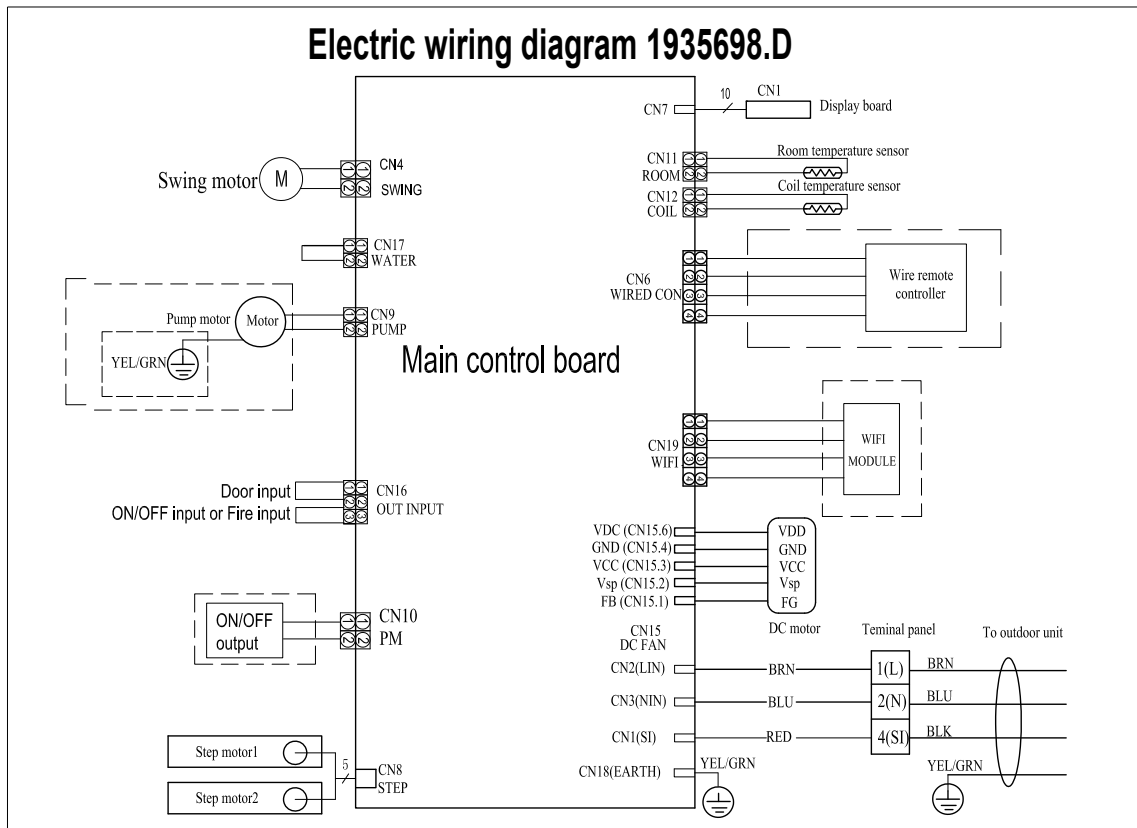

Remark:

Dashed parts are not available in some models.
Details see the table below.

	Indoor units model	Step motor	Pump motor	WIFI module	Display board	Wire remote controller	ON/OFF output
Floor ceiling	48K/60K	●			●		●

●--available part

11. WIRING DIAGRAM

Console type (9K/12K)

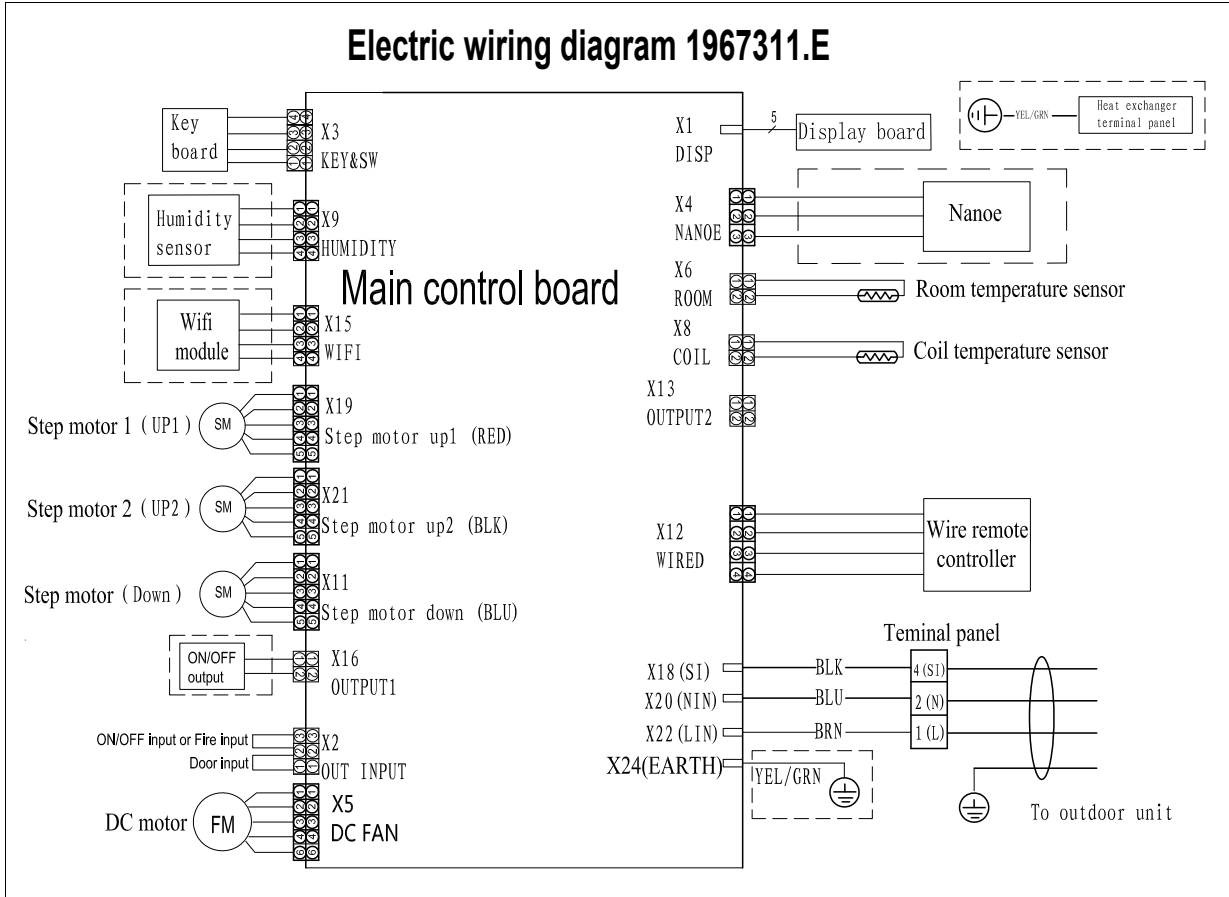

Remark:
Dashed parts are not available in some models.
Details see the table below.

Indoor unit	Humidity sensor	Wifi module	Outside input	Wire remote controller	Nanoe	Heat exchanger terminal panel	ON/OFF output
9K/12K			●			●	●

●--available part

11. WIRING DIAGRAM

Outdoor unit

9K~30K

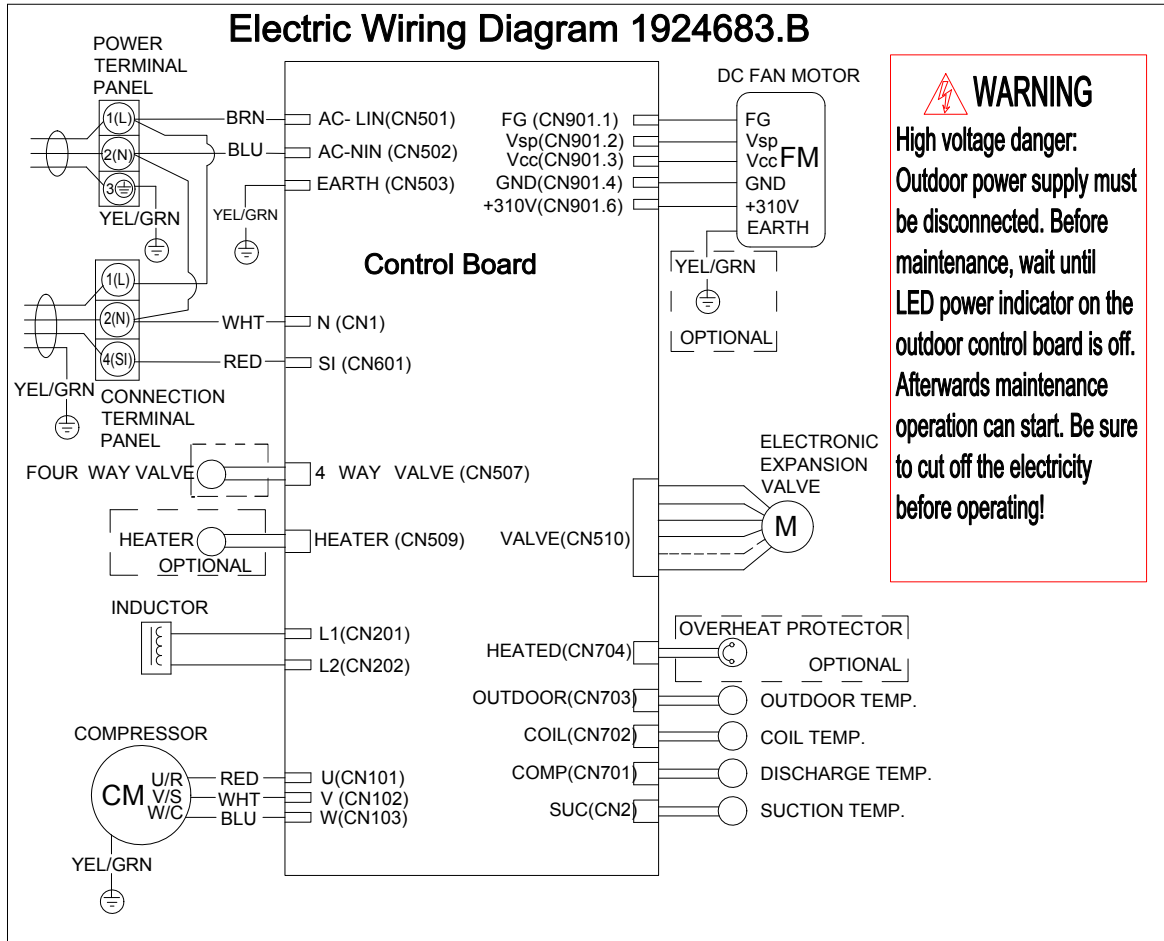

WARNING
 High voltage danger:
 Outdoor power supply must be disconnected. Before maintenance, wait until LED power indicator on the outdoor control board is off. Afterwards maintenance operation can start. Be sure to cut off the electricity before operating!

Remark:

Dashed parts are not available in some models. Details see the table below.

Outdoor unit model	Heater	Overheat protector	4-way valve	YEL/GRN
9K/12K/18K/24K/30K	●		●	

●--available part

11. WIRING DIAGRAM

36K

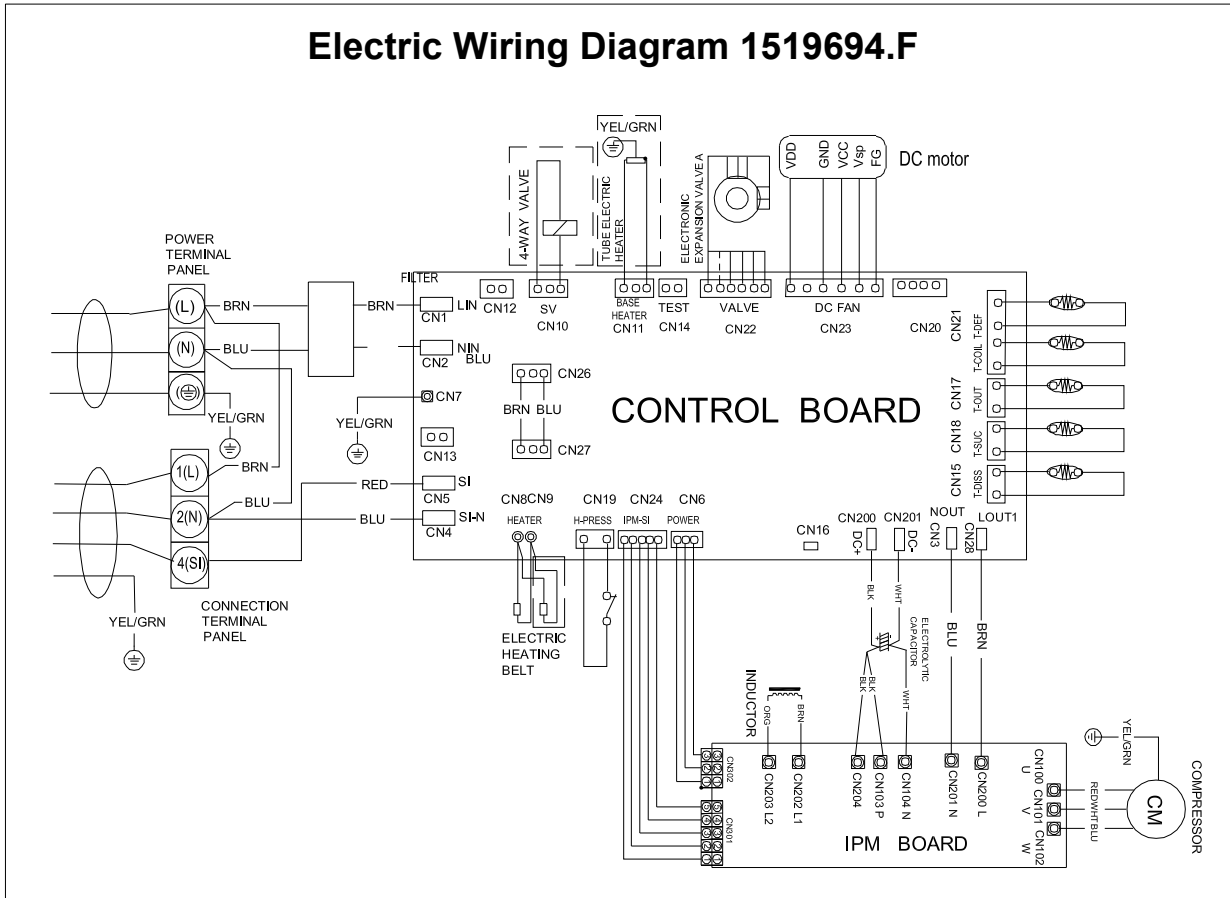

Remark:
Dashed parts are not available in some models.
Details see the table below.

Outdoor unit model	Base heater	4-Way valve
36K		●

● --available part

11. WIRING DIAGRAM

42K

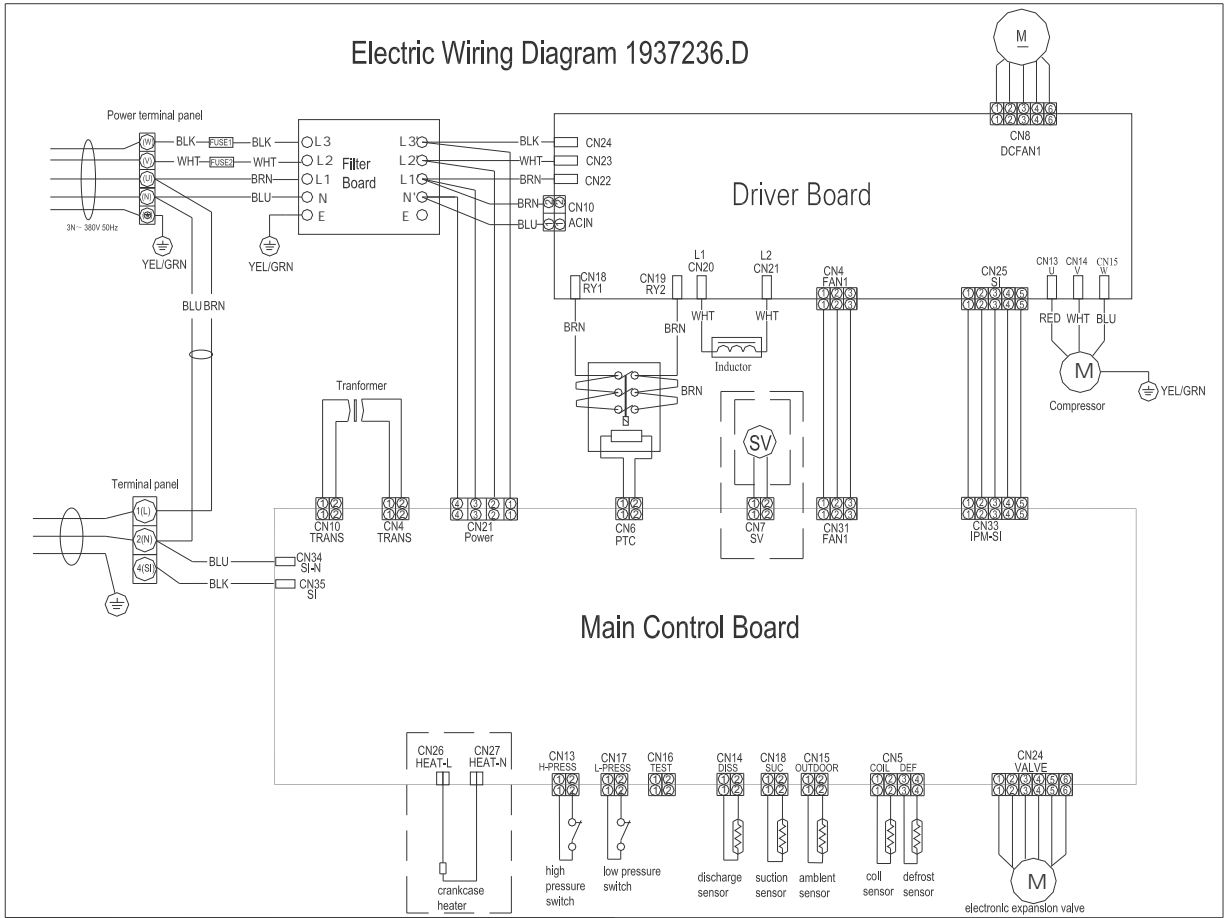

Remark:
Dashed parts are not available in some models.
Details see the table below.

Outdoor unit model	Crankcase heater
42K	●

●--available part

11. WIRING DIAGRAM

48K/60K

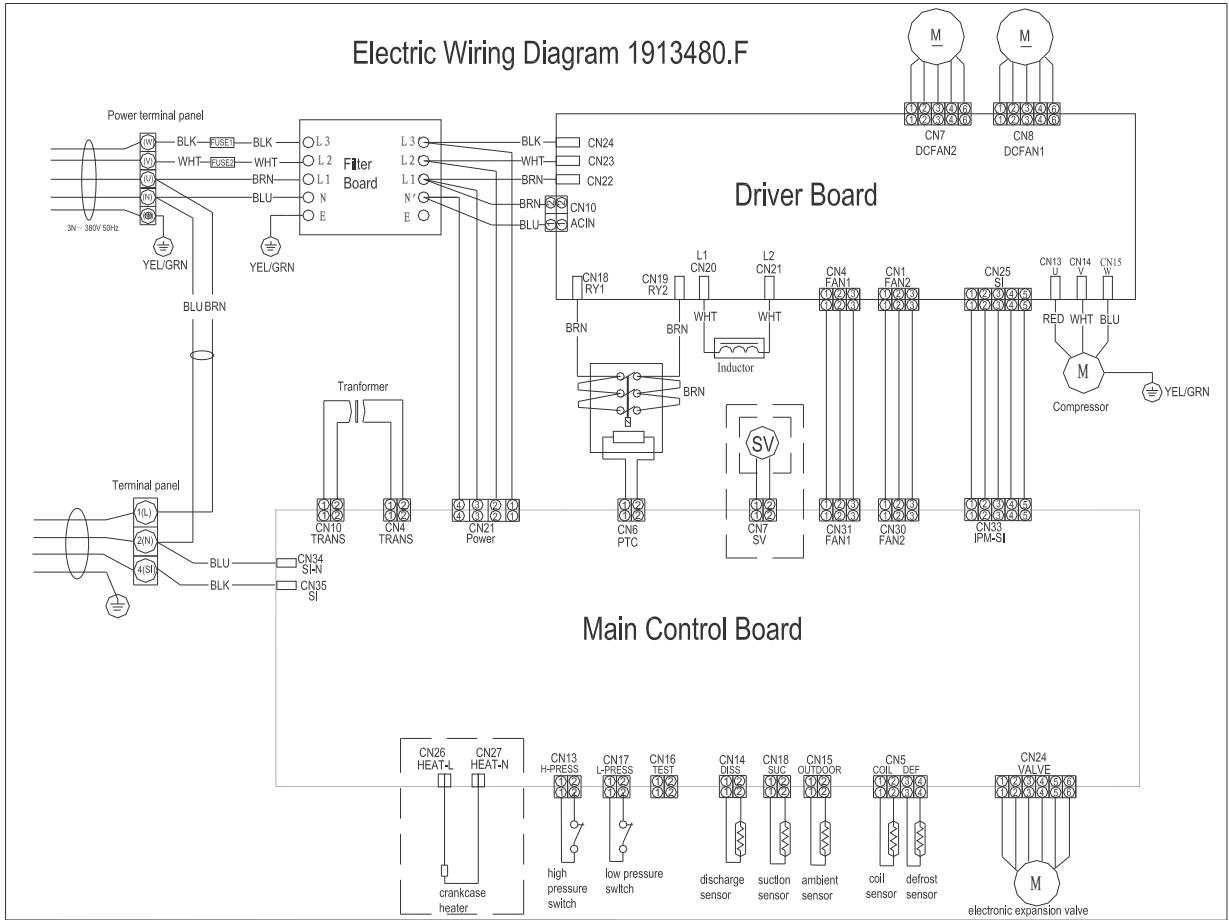

Remark:

Dashed parts are not available in some models.
 Details see the table below.

Outdoor unit model	Crankcase heater
48K/60K	●

●--available part

11. WIRING DIAGRAM

11.2 Control board picture

Indoor unit

9K~24K(Duct)

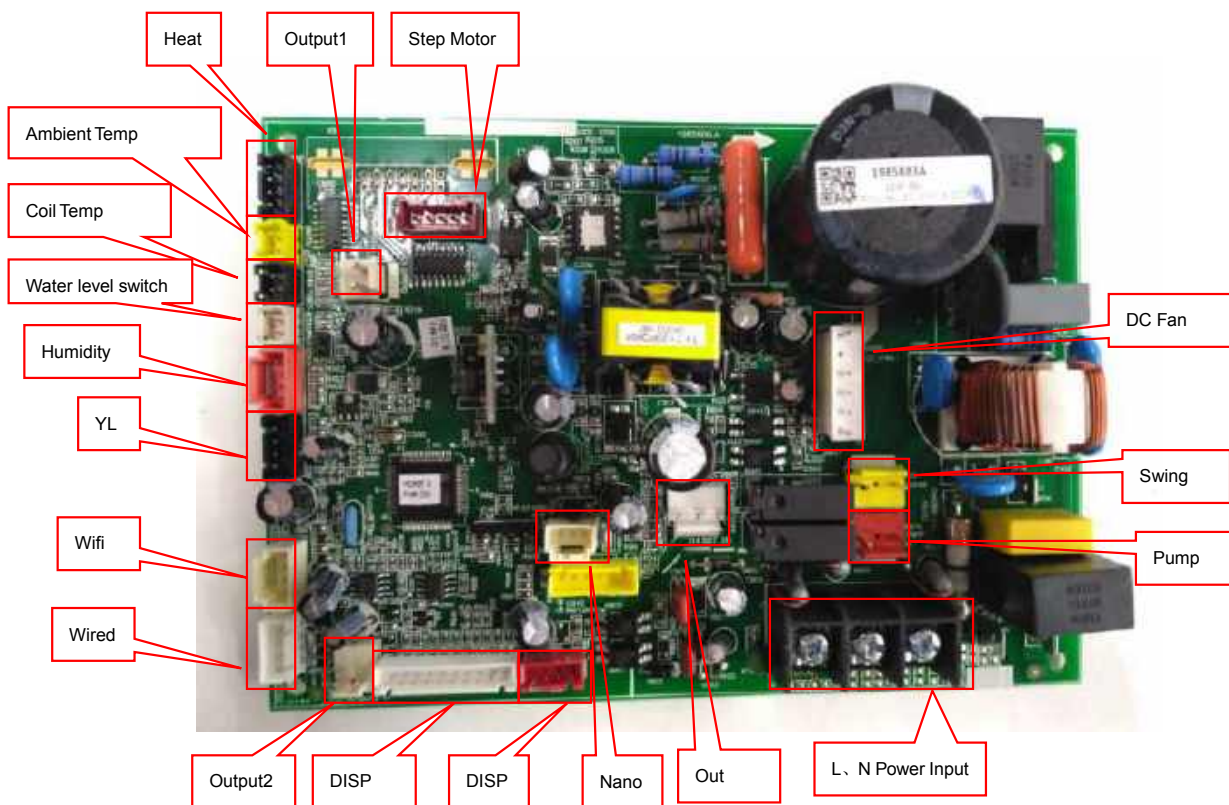

9K~18K (Console)

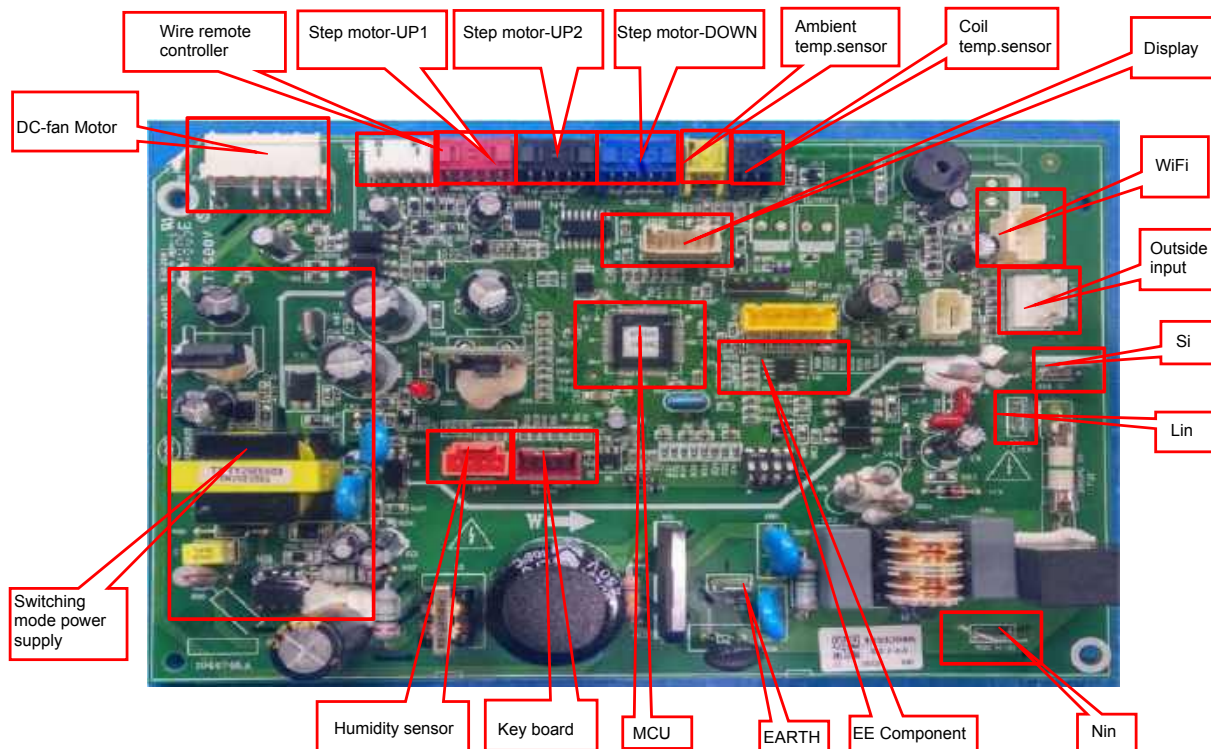

11. WIRING DIAGRAM

18K~60K

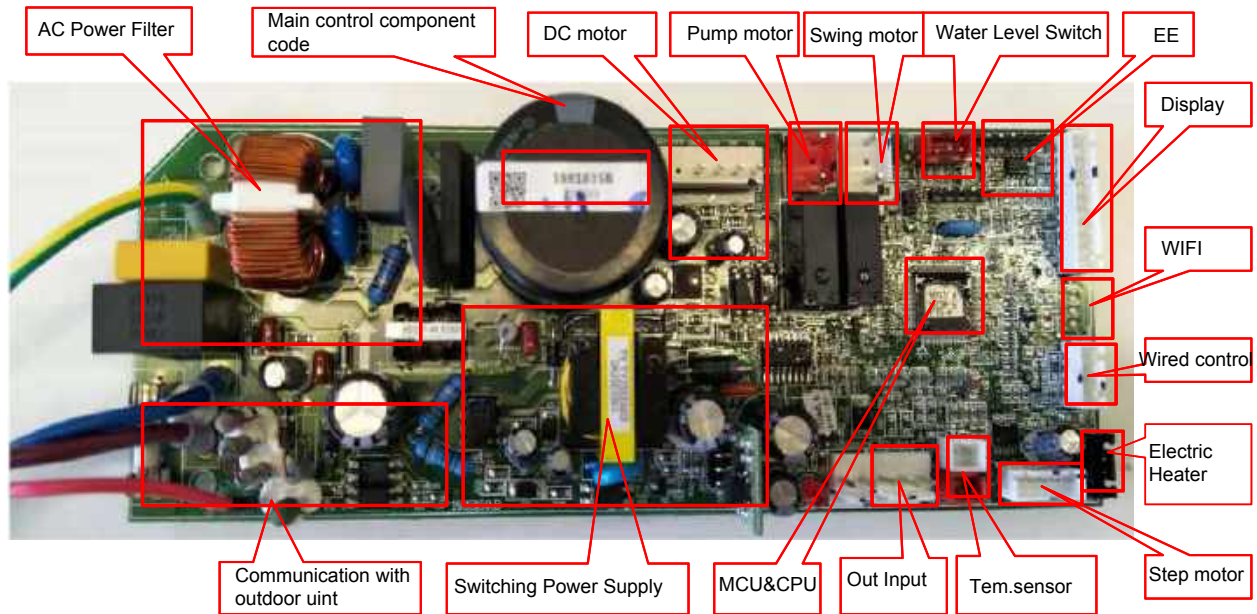

11. WIRING DIAGRAM

Outdoor unit

9K/12K

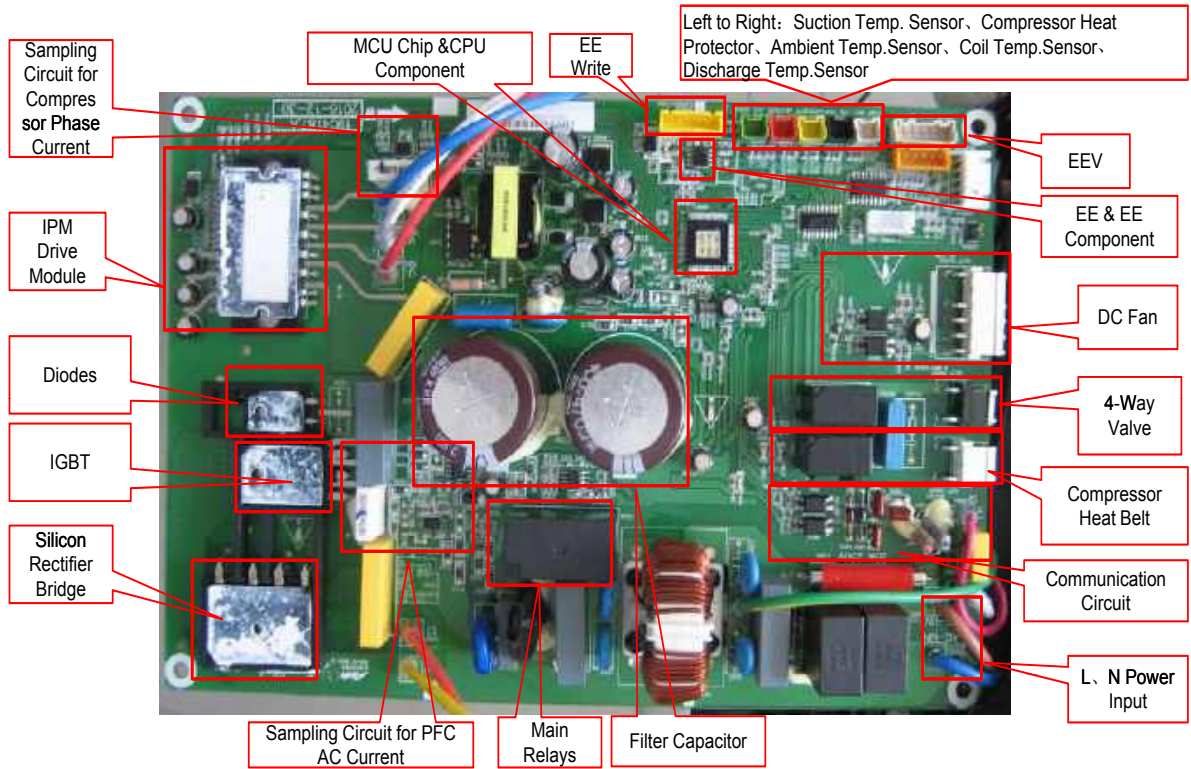

24K/30K

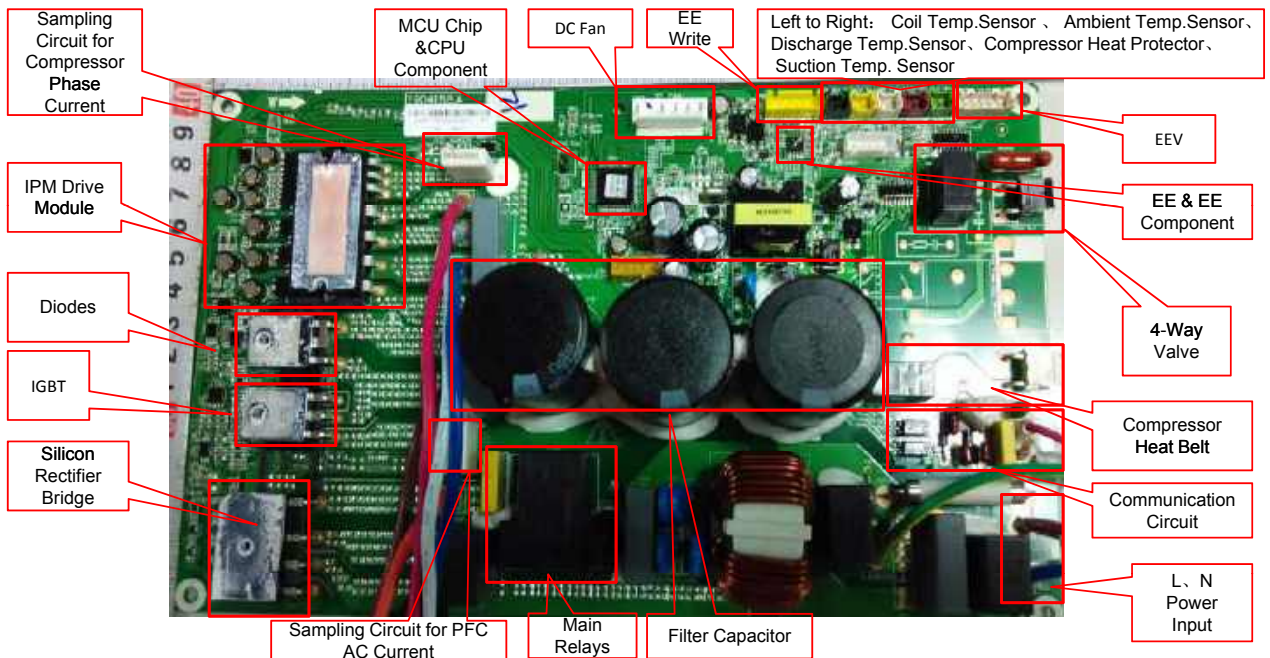

11. WIRING DIAGRAM

36K
Main control board

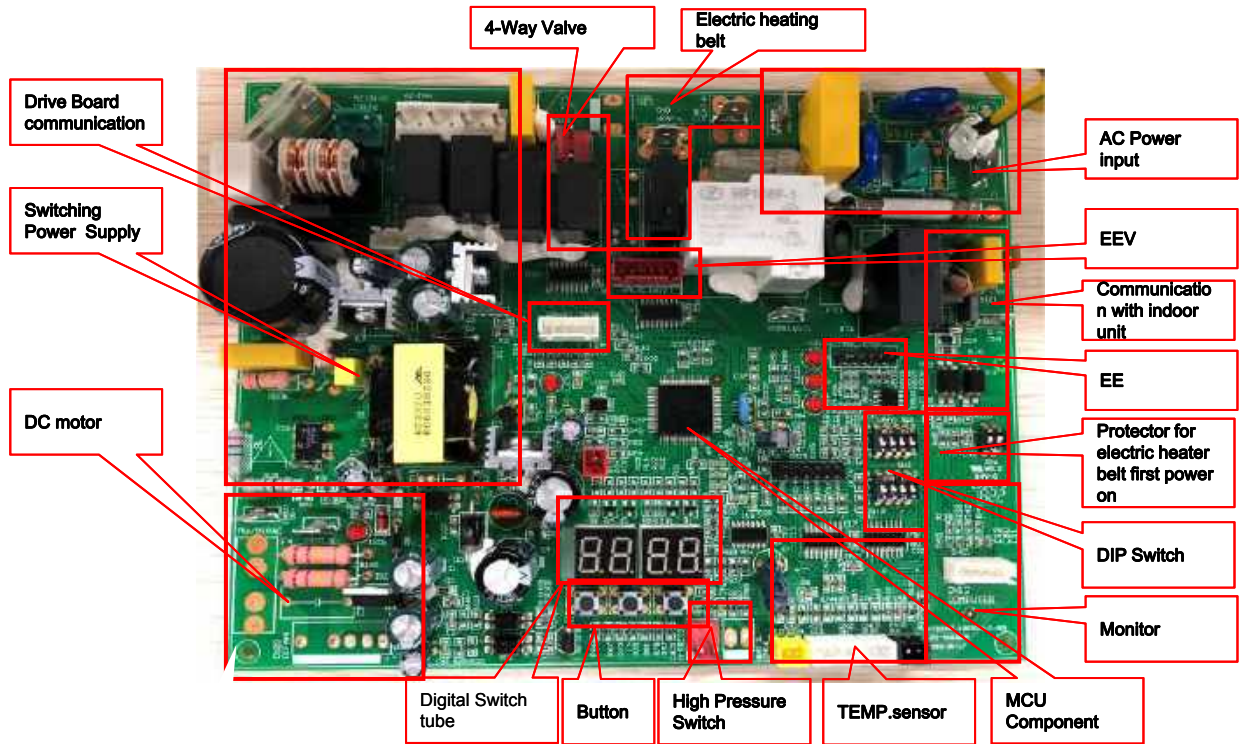

Drive board

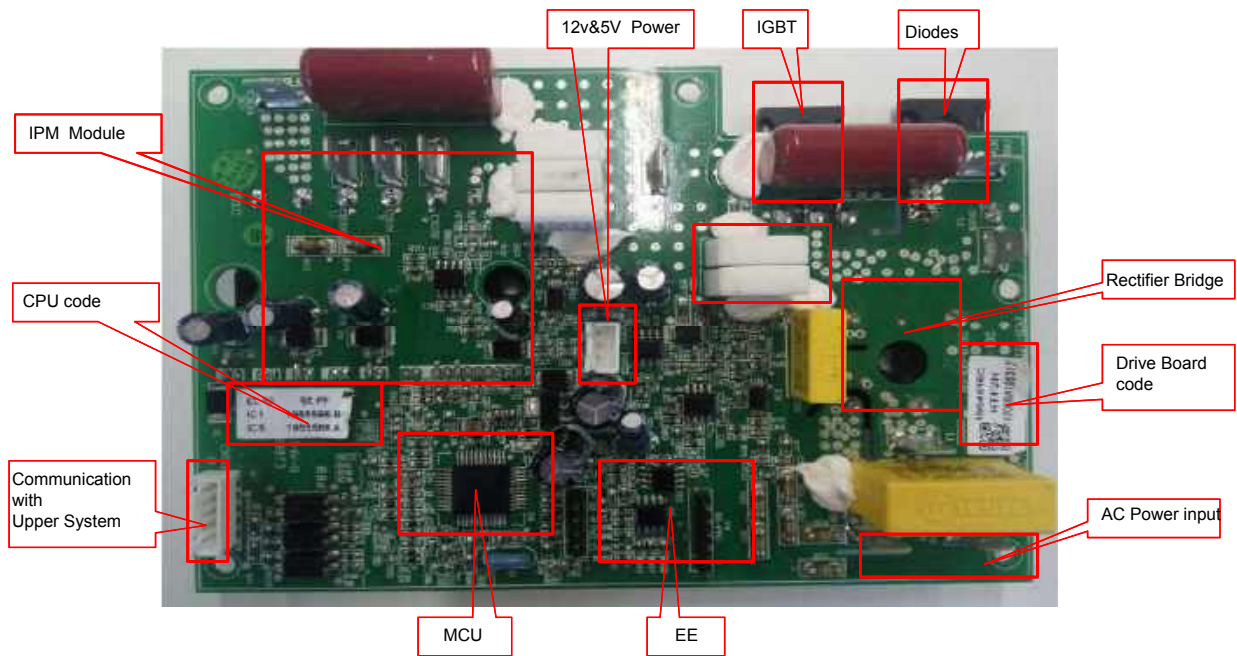

11. WIRING DIAGRAM

42K/48K/60K
Main control board

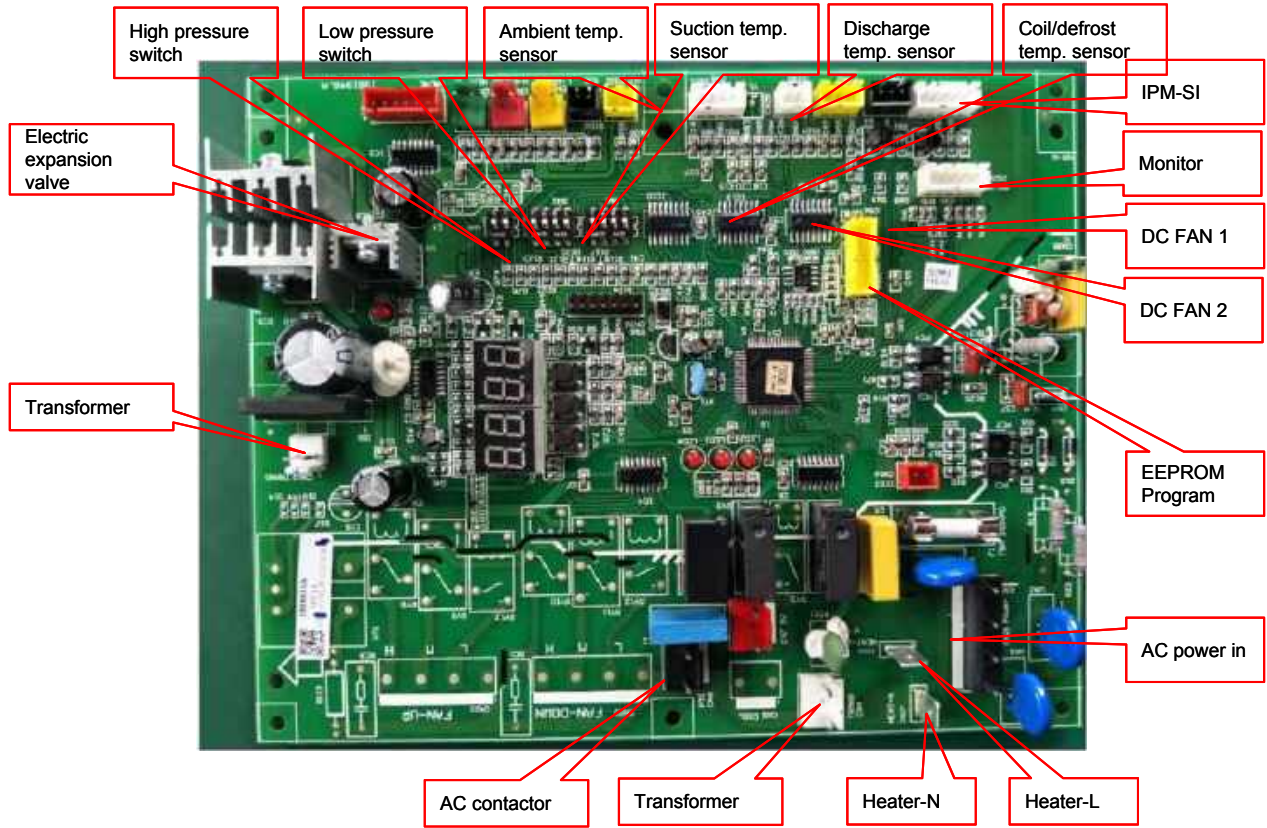

Drive board

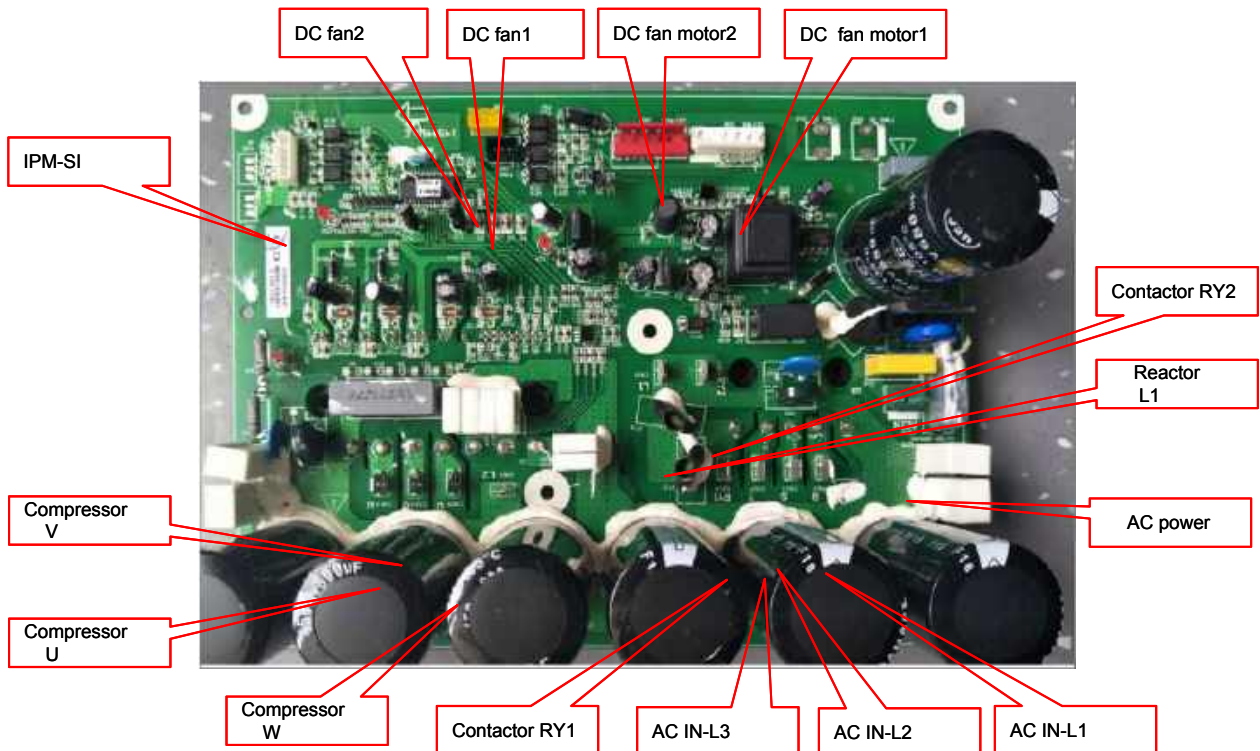

11. WIRING DIAGRAM

11.3 Common wiring

Recommend Wire Size

Model (Capacity)	Power Supply	ELB		Power Source Cable Size	Transmitting Cable Size
		Rated Current (A)	Nominal Sensitive Current (mA)	EN60335-1*1	EN60335-1*1
9K/12K	220-240V ~, 50Hz	20	30	3×1.5mm ²	4×1.5mm ²
18K	220-240V ~, 50Hz	20	30	3×2.5mm ²	4×1.5mm ²
24K/30K	220-240V ~, 50Hz	25	30	3×2.5mm ²	4×1.5mm ²
36K	220-240V ~, 50Hz	40	30	3×4.0mm ²	4×1.5mm ²
42K/48K/60K	380-415V 3N ~,50Hz	32	30	5×2.5mm ²	4×1.5mm ²

Max. Running Current (A): REFER TO NAMEPLATE

- Use an ELB (Electric Leakage Breaker).
- Do not operate the system until all the check points have been cleared.
 - (A) Check to ensure that the insulation resistance is more than 2 Mega Ohm, by measuring the resistance between ground and the terminal of the electrical parts. If not, do not operate the system until the electrical leakage is found and repaired.
 - (B) Check to ensure that the stop valves of the outdoor unit are fully opened and then start the system.
- Pay attention to the following items while the system is running.

Do not touch any of the parts by hand at the discharge gas side, since the compressor chamber and the pipes at the discharge side are heated higher than 90°C.

Note:

- (1) Follow local codes and regulations when select field wires, and all the above are the minimum wire size.
- (2) Use the wires which are not lighter than the ordinary polychloroprene sheathed flexible cord. (Cord designation H07RN-F).
- (3) The wire sizes marked with *1 in the above table are selected at the maximum current of the unit according to the European Standard, EN60335-1.
- (4) When transmitting cable length is more than 15 meters, a larger wire size should be selected.
- (5) Install main switch and ELB for each system separately. Select the high response type ELB that is acted within 0.1 second. Recommended capacity to see outdoor machine switch capacity.
- (6) In the case that power cables are connected in series, add each unit maximum current and select wires below.

11. WIRING DIAGRAM

Selection According to EN60335-1

Current i(A)	Wire Size(mm ²)
$i \leq 6$	0.75
$6 < i \leq 10$	1
$10 < i \leq 16$	1.5
$16 < i \leq 25$	2.5
$25 < i \leq 32$	4
$32 < i \leq 40$	6
$40 < i \leq 63$	10
$63 < i$	*

* in the case that current exceeds 63A, do not connect cables in series.

12. FIELD SETTING

12. Field setting

12.1 Indoor unit air flow DIP switch

Change the air flow dip switch to ON to limit the air flow direction.

Step:

- (1) Remove the front grille.
- (2) Switch the dipswitch on right side of the panel to ON.

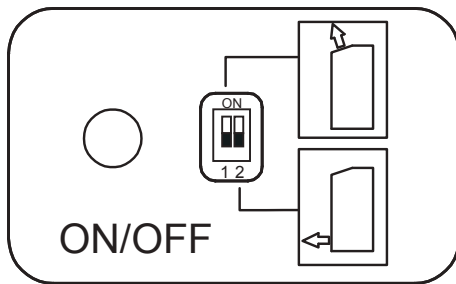

Switch setting	Air flow	
	Cooling	Heating
 ON 1 2		
 ON 1 2		
 ON 1 2		
 ON 1 2		

12. FIELD SETTING

12.2 Outdoor unit DIP switch

Dip Switch Setting of Outdoor Unit

Turn off all power sources before setting. Without turning off, the switches settings are not refreshed and might be invalid. Mark of "■" indicates the position of dip switches.

SW2	Refrigerant Piping Length Setting			
Setting is required				
Actual Piping Length L(m)				
$L < 15$		$15 \leq L \leq \text{Max.Length allowed}$		
Setting before Shipment	ON <input type="checkbox"/> OFF <input checked="" type="checkbox"/>	<input type="checkbox"/> <input type="checkbox"/> <input type="checkbox"/> <input type="checkbox"/> 1 2 3 4	ON <input checked="" type="checkbox"/> OFF <input type="checkbox"/>	<input type="checkbox"/> <input type="checkbox"/> <input type="checkbox"/> <input type="checkbox"/> 1 2 3 4

After set refrigerant piping length dip switch, cooling/heating performance could be improved.

12. FIELD SETTING

12.3 ESP setting (Duct type only)

The static pressure can be freely adjusted by using specific wire remote controller.

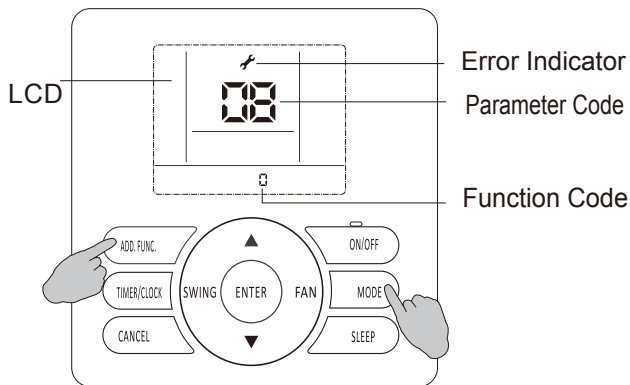

YXE-C01U(E)/YXE-C02U(E)

Model (Capacity Btu/h)	The range of static pressure	Function code set
9K/12K/18K	0-50Pa	0-50, more than 50 is 50 Pa, [default: 0 (0Pa)]
24K	0-40Pa	0-40, more than 40 is 40 Pa, [default: 0 (0Pa)]
30K/36K	0-120Pa	1-120, more than 120 is 120 Pa, [default: 0 (47Pa)]
42K/48K/60K	0-120Pa	1-120, more than 120 is 120 Pa, [default: 0 (60Pa)]

Static pressure setting:

- 1 Hold down both "MODE" button and "ADD.FUNC." button for 3 seconds, symbol ⚡ and parameter code blinking at the same time.
- 2 Press "▲/▼" button to adjust parameter number until display "17", and press "ENTER" button to entering system parameter adaption state, symbol ⚡ stop blinking.
- 3 Select desired parameter code 10 by pressing "▲/▼" button, and press "ENTER" button to confirm.
- 4 Select desired function code to rewrite the parameter values by pressing "▲/▼" button, and press "ENTER" button to confirm.
- 5 Press "ON/OFF" button or "CANCEL" button to quit.

12. FIELD SETTING

12.4 Indoor unit parameter revision

1) Connect wire remote controller with indoor unit

Step 1: Removing the upper cover of the wired controller

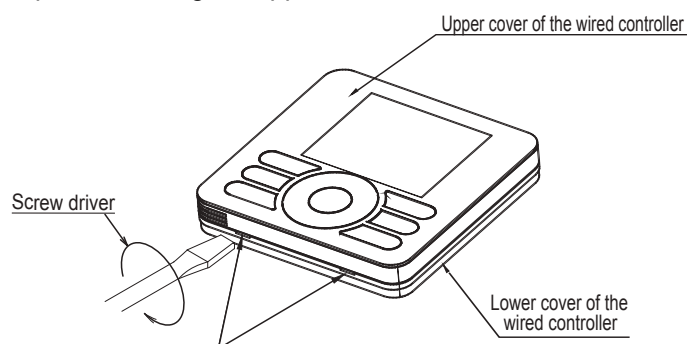

Insert a normal screw driver into the position, and gently rotate it. In this way, the upper cover can be easily removed.

Note:

Control board of the remote controller is placed on upper cover. Please protect it from being scratched during removal and installation!

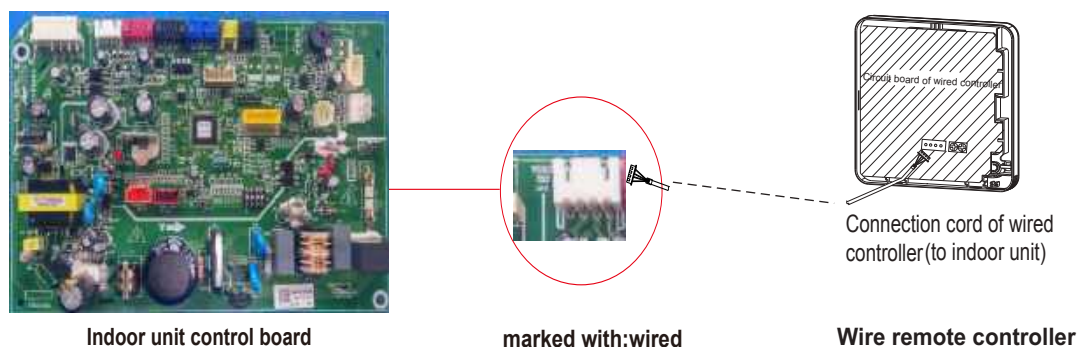

Step 2: Connecting wired controller with indoor unit

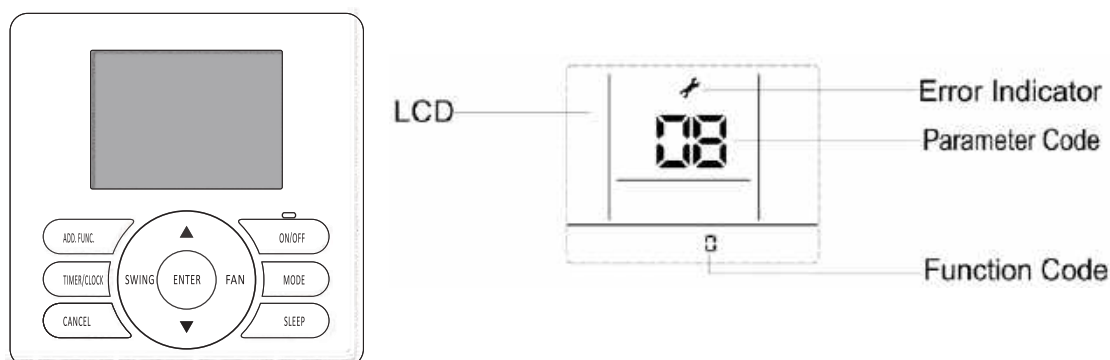

2. Changing system parameter



OPERATION:

- ① Hold down both "MODE" button and "ADD.FUNC." button for 3 seconds, symbol  and parameter number blinking at the same time.
- ② Press "▲" "▼" button to adjust parameter number until display "17".
And press "ENTER" button to entering system parameter adaption state, symbol  stop blinking, parameter number blink.
- ③ Select desired parameter code by pressing "▲"/ "▼" button following the table below, and press "ENTER" button to confirm.
- ④ Select desired function code by pressing "▲"/ "▼" button, and press "ENTER" button to confirm.

12. FIELD SETTING

PARAMETER CODE	PARAMETER DESCRIPTION	PARAMETER VALUE&REPRESENTATION		NOTE
		DATA TYPE	REPRESENTATION (FUNCTION CODE)	
1	Self Recovery of Power Break	Integer	0: Cancel Self Recovery of Power Break function; 1: Self Recovery of Power Break; others: invalid	
2	Temperature Type	Integer	0: Centigrade Temperature; 1: Fahrenheit Temperature; others: invalid	
3	Temperature Display Type	Integer	0: Default display set temperature; 1: Default display room temperature; others: invalid	
4	Ratio of ambient temperature sensed by indoor temperature sensor(cooling mode)	Integer	0~10valid, more than 10 default is10 0: 0%; 1: 10%; ...; 10: 100%	0-entirely use temperature sensed by wired remote controller; 10-entirely use temperature sensed by indoor unit
5	Filter Clean Indication	Integer	0: Cancel Filter Clean prompt function; 1: Set Filter Clean prompt function; others: invalid	
6	Filter Clean Time Set	Integer	0~32, more than 32 default is 32*1000h	
7	Installation Height Compensation	Integer	0~10m, more than 10m default is 10. =0,1,2 :no fan speed compensation; =3: increase fan speed; =4~10: increase more fan speed.	
8	Cooling Temperature Compensation (indoor unit temperature sensor)	Integer	0 : 0°C ; 1 : -0.5°C ; 2 : -1°C ; 3 : -1.5°C ; 4 : -2°C ; 5 : -2.5°C ; 6 : -3°C ; 7 : -3.5°C ; 8 : -4°C ; 9 : -4.5°C ; 10 : -5°C. (the wired controller displays integer with the symbol)	
9	Heating Temperature Compensation (indoor unit temperature sensor)	Integer	0 : 0°C ; 1 : -0.5°C ; 2 : -1°C ; 3 : -1.5°C ; 4 : -2°C ; 5 : -2.5°C ; 6 : -3°C ; 7 : -3.5°C ; 8 : -4°C ; 9 : -4.5°C ; 10 : -5°C.(the wired controller displays integer with the symbol)	
10	Static Pressure Set	Integer	1~240, function code=static pressure more than the limit static pressure default the limit static pressure. Default is 0(default static pressure, related to models)	Duct type (DC motor)
12	Ratio of temperature sensed by indoor temperature sensor (Heating mode)	Integer	0~10valid, more than 10 default is10 0: 0%; 1: 10%; ...; 10: 100%	0-entirely use temperature sensed by wired remote controller; 10-entirely use temperature sensed by indoor unit
13	Temperature Adjustment-Cooling	Character	-10~10°C (Single Character with symbol)	Temperature displayed on wired controller
14	Temperature Adjustment-Heating	Character	-10~10°C (Single Character with symbol)	Temperature displayed on wired controller
25	Access control, fire protection, ON/OFF function set	Integer	=0, Access control, fire protection functions are all invalid; =1, Access control function is valid; =2, fire protection function is valid; =3, Access control, fire protection are all valid; =4, ON/OFF function are all valid.	

12. FIELD SETTING

Query by digital tube switch

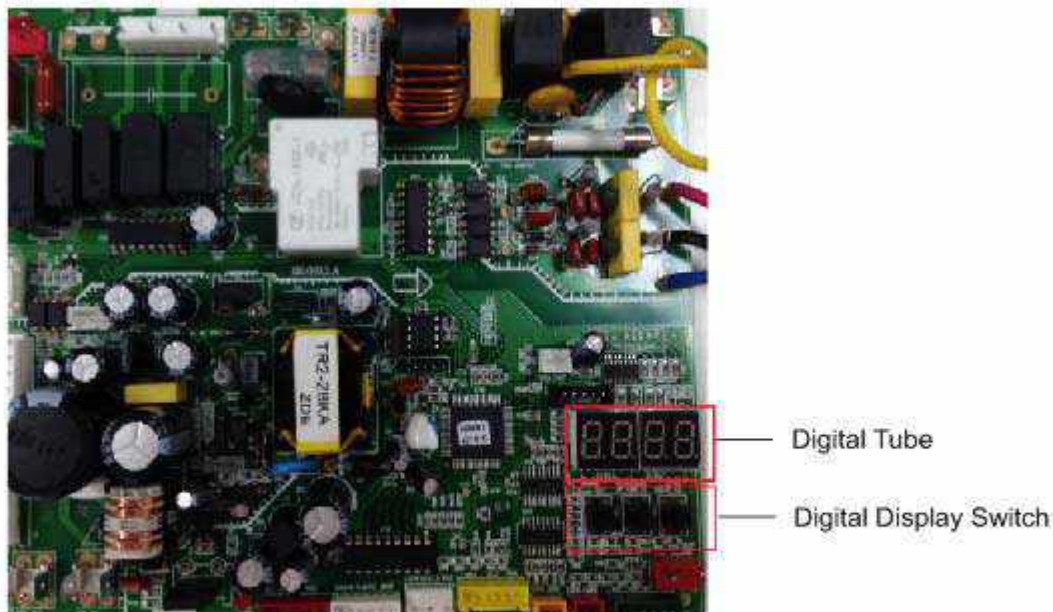

DC-Inverter outdoor control board

Digital Display Switch Introduction

It can be used to check outdoor running parameters.

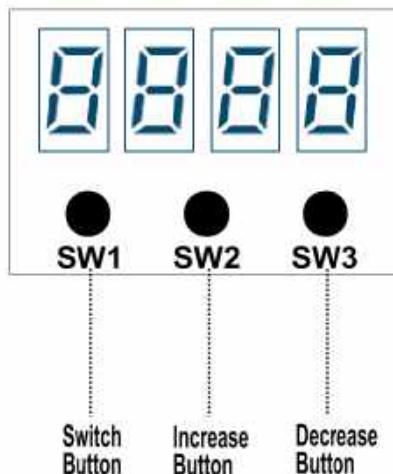

There are 3 buttons on the digital display board :

- 1) SWITCH button : Indoor parameters and outdoor parameters can be selected in turn by pressing it.
"P."-outdoor unit parameter , "H."-indoor unit parameter ;
- 2) INCREASE button : Each time it is pressed, the number rises by 1,hold down it, the number will be rapidly increase;
- 3) DECREASE button : Each time it is pressed, the number lowers by 1,hold down it, the number will rapidly decreased.
- 4) The parameters will be displayed after 3s when the checking numbers are selected.

12. FIELD SETTING

Parameters can be checked as following table below.

Parameter code	Descriptions
0	Protect Code or Fault code
P.1	Target Frequency
P.2	Driving Frequency
P.4	Outdoor EEV Opening
P.5	Outdoor EEV Target Opening
P.6	Upper DC Motor Revolving Speed
P.8	AC Input Voltage
P.9	Current
P.10	Modular Temperature
P.11	Capacity Needed
P.12	Modular Fault
P.20	Outdoor Ambient Temperature
P.21	Outdoor Coil Temperature
P.22	Outdoor Defrost Temperature
P.23	Suction Temperature
P.24	Discharge Temperature
H.1	Indoor Unit Fault
H.2	Indoor Ambient Temperature
H.3	Indoor Coil Temperature
H.4	Indoor Setting Temperature

12. FIELD SETTING

12.6 Instructions for the function setting of access control, fire protection, ON/OFF

12.6.1 Factory setting

ON/OFF function is disabled as factory default while both the access control and fire protection functions are enabled.

To use or cancel the access control / fire protection / (ON/OFF) function, use the wired controller to modify the parameters of indoor unit.

Note:

Please refer to "Indoor unit parameter revise" section in TC Manual for how to use the wired controller to modify the parameters of indoor unit.

12.6.2 Function introduction

(1) Access control:

Control mode to control the machine startup & shutdown based on the ON and OFF state of the access control port.

(2) Fire protection:

Control mode to control the machine startup & shutdown based on the ON and OFF state of the fire protection port.

(3) ON/OFF:

Special control mode to achieve the control of indoor unit startup & shutdown based on the input state of the fire protection port of the indoor unit (no other way can control startup & shutdown) and output the fault status of indoor unit through OUTPUT port.

12.6.3 Function setting

(1) Hardware connection

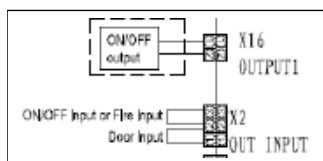

Figure 1 electrical wiring diagram



Figure 2 short wiring



Figure 3 main control board

3 pins of the OUT INPUT X2 socket shown in the electrical wiring diagram of Figure 1 will be in short circuited state by default factory setting (an external short circuit plug shown in Figure 2, and the OUT INPUT X2 socket of main control board as shown in Figure 3).

(Note: the socket number in circuit is subject to the actual serial number of PCB.)

12. FIELD SETTING

- 1) When using the door lock function, the red wire should be cut and connected to the door lock control switch attached to it (supplied by user), and the connecting wire should be 22AWG or above. In normal conditions, the unit operates normally once the switch is closed and shuts down once the switch is off.
- 2) When using the fire protection function, the white wire should be cut and connected to the fire protection lock control switch attached to it (supplied by user), and the connecting wire should be 22AWG or above. In normal conditions, the unit operates normally once the switch is closed and shuts down once the switch is off.
- 3) When using the ON/OFF function, the white wire should be cut and connected to the door lock control switch attached to it (supplied by user), and the connecting wire should be 22AWG or above. In normal conditions, the unit operates normally once the switch is closed and shuts down once the switch is off.

(2) Timing sequence description:

4) Access control

- 1) Control of entrance card disconnection: the air conditioner will shut down if the access control signal is disconnected for 30 seconds. In this state, the indoor unit cannot start. If the user performs start operation, the wired controller will not respond and displays power-off status.
 - 2) Control of entrance card connection: after the closed circuit of entrance card interface, power-on restrictions are released, the wired controller maintains power-off and the startup & shutdown control is enabled.
- Fire protection
 - 1) Access to fire protection: the air conditioner will shut down and stop blowing air after the access control signal is disconnected for 3 seconds. In this state, the indoor unit cannot be started. If the user performs start operation, the wired controller shall not respond and displays power-off status.
 - 2) Cancellation of fire protection: after the short circuit of fire protection signal, release power-on restrictions, the wired controller maintains power-off status and the startup & shutdown control is enabled.
 - ON/OFF
 - 1) In the situation where ON/OFF function is enabled, the port is closed and in short circuit, the indoor unit starts; the indoor unit shuts down once the port is disconnected;
 - 2) Other operation information (such as mode, air speed, air door, and so on.) except for startup & shutdown can be set through the wired controller, remote-controller and WIFI module, priority is given to the latest command received.
 - 3) In the mode of ON/OFF function, wired controller, remote-controller, WIFI module and access control cannot control the unit startup & shutdown, neither the operation mode, timer or sleeping mode.
 - 4) There will be 12V signal output when machine fault occurs.

(3) Relative priorities of instructions

ON/OFF has the highest priority. The access control function shall be disabled when ON/OFF is enabled. Access control and fire prevention functions shall not affect each other.

NOTE:

Figures in the manual are only simple representation of the control board, it's may not comply with the appearance that you purchased.

13. PIPING WORK AND REFRIGERANT CHARGE

13. Piping work and refrigerant charge

13.1 MAX. length allowed

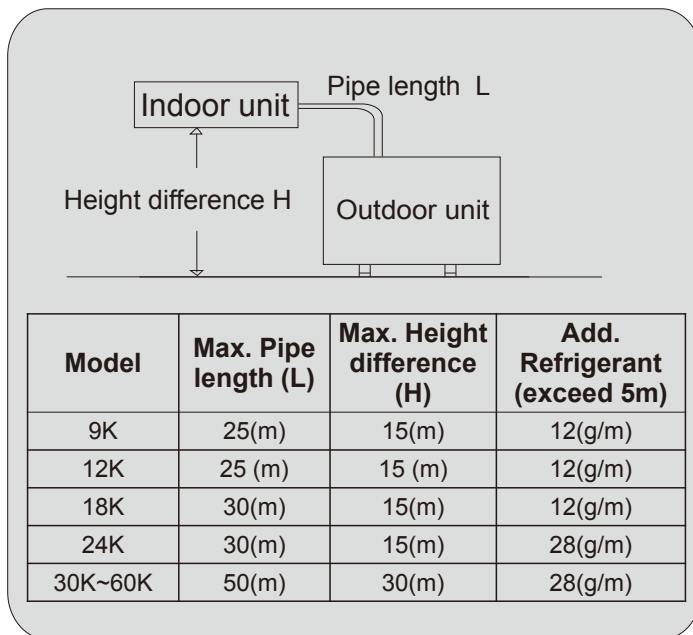

Refrigerant Additional Charge

The unit has been filled with refrigerant, but if exceeds 5m, additional refrigerant (R32) change is required. For 9K~18K: Additional refrigerant charge $= (L-5) \times 12g/m$

For 24K~60K: Additional refrigerant charge $= (L-5) \times 28g/m$

13.2 Oil trap

When the indoor unit is lower than outdoor unit and height is larger than 5m, install an oil trap every 5m (height difference) on suction piping.

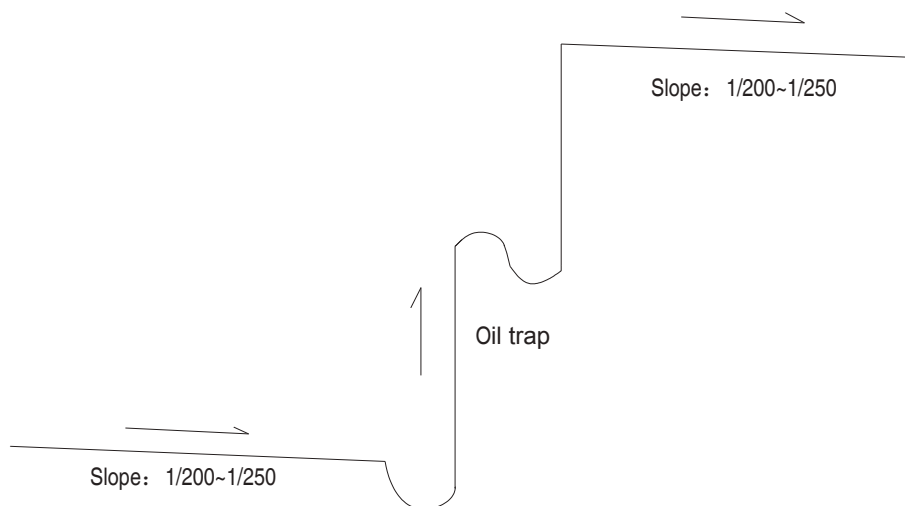

NOTE:

1. To avoid storing too much oil in the oil trap, the oil trap should be as short as possible.
2. The horizontal piping should be slope down along the refrigerant flow direction, to bring the oil back to compressor, the slope is about 1/200 to 1/250.
3. To ensure better performance of cooling/heating, the refrigerant piping should be short and straight as much as possible.

13. PIPING WORK AND REFRIGERANT CHARGE

13.3 Air tight test

Do use nitrogen when performing air-tight test.

Connect the gauge manifold using charging hoses with a nitrogen cylinder to the check joints of the liquid line and the gas line stop valves. Perform the air-tight test. Don't open the gas line stop valves. Apply nitrogen gas pressure of 4.3MPa. Check for any gas leakage at the flare nut connections, or brazed parts by gas leak detector or foaming agent. Gas pressure does not decrease is OK. After the air tight test, release nitrogen gas.

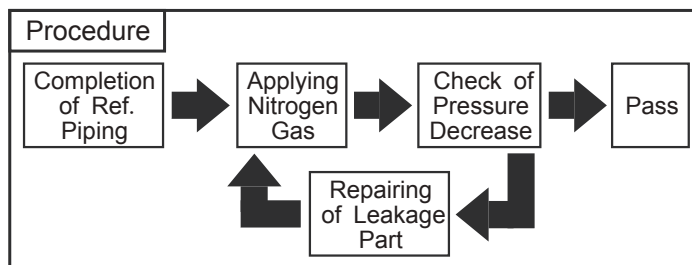

Air tight procedure

13. PIPING WORK AND REFRIGERANT CHARGE

13.4 Additional refrigerant charge

Although refrigerant has been charged into this unit, additional refrigerant charge is required according to piping length.

- The additional refrigerant precharge quantity should be determined and charged into the system according to the following procedure.
- Record the additional refrigerant quantity in order to facilitate maintenance and servicing activities.

Refrigerant charge before shipment (W0 (kg))

W0 is the outdoor unit refrigerant charge before shipment;

Xg is additional refrigerant outdoor unit needed to charge according to piping length during installation.

Model	Refrigerant precharged before shipment(W0(g))	Total refrigerant pipe length	
		0m~5m	Long than 5m
9K	750	0g	$Xg = 12g / m \times (\text{Total pipe length}(m) - 5)$
12K	850	0g	$Xg = 12g / m \times (\text{Total pipe length}(m) - 5)$
24K	1400	0g	$Xg = 28g / m \times (\text{Total pipe length}(m) - 5)$
30K	1450	0g	$Xg = 28g / m \times (\text{Total pipe length}(m) - 5)$
36K	2000	0g	$Xg = 28g / m \times (\text{Total pipe length}(m) - 5)$
42K	2500	0g	$Xg = 28g / m \times (\text{Total pipe length}(m) - 5)$
48K	3000	0g	$Xg = 28g / m \times (\text{Total pipe length}(m) - 5)$
60K	3950	0g	$Xg = 28g / m \times (\text{Total pipe length}(m) - 5)$

14. INSTALLATION TOOLS AND INSTALLATION FLOW CHART

14.1 Necessary tools and instrument list for installation

No.	Tool	No.	Tool	No.	Tool	No.	Tool
1	Handsaw	6	Copper Pipe Bender	11	Spanner	16	Leveler
2	Phillips Screwdriver	7	Manual Water Pump	12	Charging Cylinder	17	Clamper for Solderless Terminals
3	Vacuum Pump	8	Pipe Cutter	13	Gauge Manifold	18	Hoist (for Indoor Unit)
4	Refrigerant Gas Hose	9	Brazing Kit	14	Cutter for Wires	19	Ammeter
5	Megohmmeter	10	Hexagon Wrench	15	Gas Leak Detector	20	Voltage Meter

Use tools and measuring instruments only for the new refrigerant which is directly touch to refrigerant.

◇: Interchangeability is available with R410A

●: Only for Refrigerant R32

×: Prohibited

◆: Only for Refrigerant R22

Measuring Instrument and Tool for R410A	R32	R22	Reason of Non-Interchangeability and Attention (*: Strictly Required)	Use	
Refrigerant Pipe	Pipe Cutter	◇	◇	-	Cutting Pipe
	Chamfering Reamer	◇	◇	-	Removing Burrs
	Flaring Tool	◇	◇	* The flaring tools for R32 are applicable to R22/R410A. * If using flaring tube, make dimension of tube larger for R410A. * In case of material 1/2H, flaring is not available.	Flaring for Tubes
	Pipe Bender	◇	◇	* In case of material 1/2H, bending is not available. Use elbow for bend and braze.	Bending
	Expanding Tool	◇	◇	* In case of material 1/2H, expanding of tube is not available. Use socket for connecting tube.	Expanding Tubes
	Torque Wrench	◇	××	* For $\phi 1/2$, $\phi 5/8$, spanner size is up 2mm.	Connection of Flare Nut
		◇	◇	* For $\phi 1/4$, $\phi 3/8$, $\phi 3/4$, spanner size is the same.	
	Brazing Tool	◇	◇	* Perform correct brazing work.	Brazing for Tubes
Nitrogen Gas	◇	◇	* Strict Control against Contamin (Blow nitrogen during brazing.)	Prevention from Oxidation during Brazing	
Lubrication Oil (for Flare Surface)	●	◆	* Use a synthetic oil which is equivalent to the oil used in the refrigeration cycle. * Synthetic oil absorbs moisture quickly.	Applying Oil to the Flared Surface	
Vacuum Drying & Refrigerant Charge	Refrigerant Cylinder	×	×	* Check refrigerant cylinder color. * Liquid refrigerant charging is required regarding zeotropic refrigerant. * Use the weight scale.	Refrigerant Charging
	Vacuum Pump	◇	◇	* The current ones are applicable. However, it is required to mount a vacuum pump adapter which can prevent from reverse flow when a vacuum pump stops, resulting in no reverse oil flow.	Vacuum Pumping
	Adapter for Vacuum Pump	◇	◆	-	Vacuum Pumping, Vacuum Holding, Refrigerant Charging and Check of Pressures
	Manifold Valve	◇	◆	* No interchangeability is available due to higher pressures when compared with R22. * Do not use current ones to the different refrigerant. If used, mineral oil will flow into the cycle and cause sludges, resulting in clogging or compressor failure.	
	Charging Hose	◇	×	* Connection diameter is different; R32/R410A: UNF1/2, R22: UNF7/16.	
	Weight Scale	◇	◇	-	Measuring Instrument for Refrigerant Charging
	Refrigerant Gas Leakage Detector	×	×	* The current gas leakage detector (R22) is not applicable due to different detecting method.	Gas Leakage Check

14. INSTALLATION TOOLS AND INSTALLATION FLOW CHART

14.2 Installation flow chart

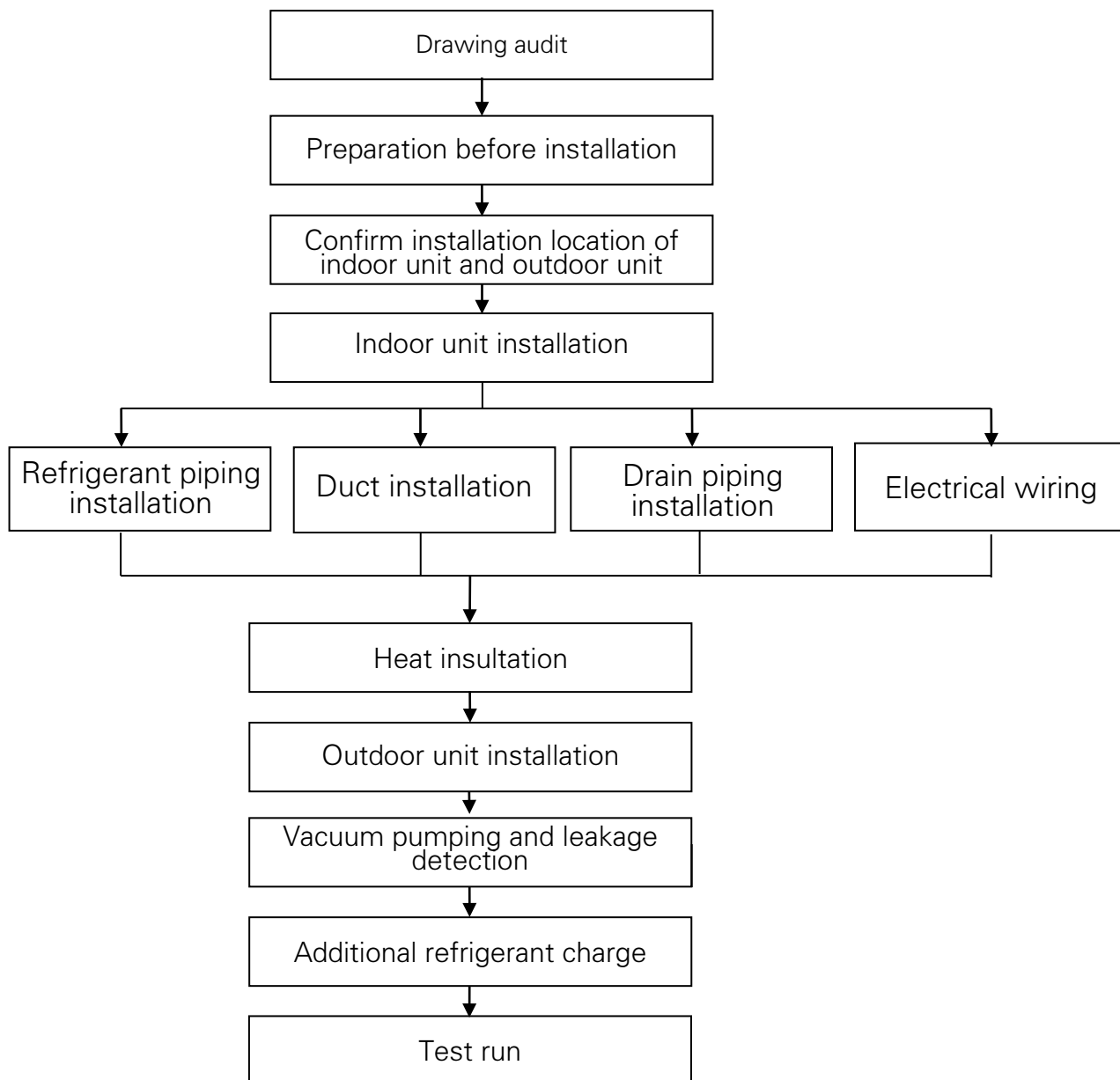

Note: this flow is only for reference; detailed see installation manual section.

15. CONTROL MODE

15. Control mode

15.1 Indoor unit mode control

1. Main general technical parameters

- (1) Remote receiver distance: 8 m.
- (2) Remote receiver angle: Less than 80 degrees.
- (3) Temperature control accuracy: $\pm 1^{\circ}\text{C}$.
- (4) Time error: Less than 1%.

2. Functions of the control function

2.1 Emergency switch

Press the emergency button can realize the starting or closing Machine, starting up according to the automatic mode of operation.

Press this button to turn ON the unit, the machine will run in auto mode, and press it again to turn off.

When the machine is OFF, press and hold the emergency switch for 5 seconds, with 3 beeps, the indoor unit would turn to emergency running. In such situation, machine would be forced to turn to cooling operation with high speed, the flaps sweeping and the machine's operation is irrelevant with room temperatures.

If a remote signal has been received during the emergency run, the machine will operate upon the command of such a remote signal.

2.2 Operator-machine communication

Air conditioning and remote controller is provided with a temperature sensor. The remote controller on the temperature sensor detects the default settings of room temperature at room temperature. If the indoor control unit has not received remote control signal for a long time, it will automatically switch to the air conditioner body temperature sensor.

2.3 Timer function

(1) Timer on

When set to start in a time by the remote controller, the air conditioner starts in the timer on condition. When the set time is up, the air conditioner will turn on and operates in the preset conditions after receiving a signal from the remote controller. If the air conditioner has not received a signal from the remote controller when the set time is up, it will automatically start and operate in the preset conditions.

(2) Timer off

When set to stop in a set time by the remote controller, the air conditioner will start in the timer off condition. When the set time is up, the air conditioner will turn off after receiving a signal from the remote controller. If the air conditioner has not received a signal from the remote controller when the set time is up, it will turn off automatically.

(3) Neither the turning on nor turning off operation will cancel the timer function.

15. CONTROL MODE

2.4 Sleep

- (1) In the heating, cooling or dehumidifying mode, press the "Sleep" button on the remote controller to start or cancel the sleep function in turn, and at the same time the sleep icon on the display screen will be on or off accordingly.
- (2) In the heating mode, the set temperature will decrease automatically after the sleep function is started.
- (3) In the cooling mode, the set temperature will rise automatically after the sleep function is started.
- (4) By default, the setting is to cancel the sleep function. Turning off the unit will also cancel the sleep function.

2.5 Highly efficient run function (only for some remote controller)

In Cooling, Dehumidification, Fan mode, press the "HIGH POWER " to enter the refrigeration mode, set the temperature automatically adjust to lowest temp; the Fan speed is powerful speed; frequency of high frequency operation.

In heating mode, press the "HIGH POWER" to enter the refrigeration mode, set the temperature automatically adjust to highest temp.; the Fan speed is powerful speed; frequency is high frequency operation.

Mute function (only for some remote controller)

In the indoor unit operation mode, you may turn on or turn off mute function with mute key. The air conditioner will run with mute fan speed in mute mode.

2.6 Prevent cooling wind mode

In the heating-run, to prevent the indoor fan from blowing cold air, the indoor fan will stop or run slowly until the coil is warm.

2.7 Blow waste heating and waste cooling function

The heating mode, remote shutdown, such as indoor heat exchanger temperature is higher, the wind blowing out opportunities continue to run the waste heat.

Cool and dehumidification mode, after the compressor stops, indoor unit will continue to set the speed of operation for a period of time.

2.8 Dehumidifying method:

If remote control setting is in dehumidifying mode, indoor unit is forced to run at low speed (high power key or a strong bond also maintains a low wind speed), and the outdoor unit runs according to the refrigeration mode operation.

2.9 Auto re-start from of Power Break

When the power supply is recovered after a break, all presets are still effective and the air-conditioner can run according to the previous setting.

How to set/cancel:

It can be set /cancel with wired remote controller.

For details, see internal control parameter adjustment.

15. CONTROL MODE

2.10 Fault code

The fault code can be shown by digital tube on the indoor panel.

2.11 Filter clean

FC will light up when air filter is clogged with dust.

How to set/cancel: It can be set /cancel with wired remote controller.

For details, see internal control parameter adjustment.

15. CONTROL MODE

15.2 Outdoor unit mode

control Control function

1. Cooling Anti-Freeze Protection

The indoor coil sensor functions as real time temperature detector of evaporator. It prevents the indoor unit evaporator temperature becoming too low. If the indoor coil temperature is too low, the compressor will protect.

2. Overload Protection

To prevent system overload caused by excessive pressure, the machine will implement real-time detection when outdoor coil temperature too high during cooling mode or indoor coil temperature too high during heating mode.

3. Exhaust temperature protection

To prevent deterioration due to high exhaust temperature of compressor, the machine will realize the real-time detection of the exhaust gas temperature. If the temperature is too high compressor provides automatic protection.

4. Oil-return Control

When the compressor runs at low frequencies for a long time, control system will start the oil-return mechanism. The oil in the system returns to the compressor.

5. Operation Mode

Air conditioning mode is the operation mode set by users through remote controller, four modes are available: cooling, heating, dehumidification, and fan mode.

6. Four-way Valve Control

Four-way valve of the outdoor unit shuts down when cooling and defrosting but starts when heating. During the heating process, the four-way valve stops working for a period of time after compressor disconnects.

7. Start-up Protection

To prevent compressor from restarting frequently when the system pressure has not been completely balanced, it cannot be restarted within 3 minutes.

8. Pressure Protection

When the pressure increases to a preset value, the pressure switch will automatically protect. Compressor will stop and report the fault code protection.

16. SENSOR PARAMETER

16. Sensor parameter

1. THE PARAMETER OF OUTDOOR COMPRESSOR DISCHARGE TEMPERATURE

SENSOR:

($R_0=187.25K\pm 6.3\%$; $R_{100}=3.77K\pm 2.5K$; $B0/100=3979K\pm 1\%$)

T [°C]	Rmin [KΩ]	Rnom [KΩ]	Rmax [KΩ]	DR(MIN)%	DR(MAX)%
-30	908.2603	985.5274	1065.1210	-7.84	7.47
-29	855.3955	927.6043	1001.9150	-7.78	7.42
-28	805.9244	873.4324	924.8368	-7.73	5.56
-27	759.6097	822.7471	887.5944	-7.67	7.31
-26	716.2320	775.3041	835.9165	-7.62	7.25
-25	675.5881	730.8775	787.5529	-7.56	7.20
-24	637.4902	689.2583	742.2720	-7.51	7.14
-23	601.7645	650.2533	699.8601	-7.46	7.09
-22	568.2499	613.6835	660.1191	-7.40	7.03
-21	536.7970	579.3832	622.8658	-7.35	6.98
-20	507.2676	547.1989	587.9307	-7.30	6.93
-19	497.5332	516.9882	555.1565	-3.76	6.88
-18	453.4748	488.6192	524.3977	-7.19	6.82
-17	428.9819	461.9693	495.5191	-7.14	6.77
-16	405.9517	436.9251	486.3954	-7.09	10.17
-15	384.2888	413.3808	442.9105	-7.04	6.67
-14	363.9047	391.2386	418.9563	-6.99	6.62
-13	344.7169	370.4072	396.4325	-6.94	6.56
-12	326.6497	350.8019	375.2461	-6.88	6.51
-11	309.6286	332.3441	355.3104	-6.83	6.46
-10	293.5903	314.9620	336.5448	-6.79	6.41
-9	278.4719	298.5822	318.3744	-6.74	6.22
-8	264.2156	283.1464	302.2294	-6.69	6.31
-7	250.7678	268.5936	286.5448	-6.64	6.26
-6	238.0783	254.8686	271.7603	-6.59	6.22
-5	226.1003	241.9200	257.8193	-6.54	6.17
-4	214.7903	229.6997	244.6593	-6.49	6.11
-3	204.1073	218.1630	232.2612	-6.44	6.07
-2	194.0135	207.2681	220.5495	-6.39	6.02
-1	184.4732	196.9759	209.4913	-6.35	5.97
0	175.4533	187.2500	199.0468	-6.30	5.93
1	166.8952	178.0255	189.1529	-6.25	5.88
2	158.8023	169.3067	179.8058	-6.20	5.84
3	151.1467	161.0633	170.9724	-6.16	5.80
4	143.9026	153.2667	162.6216	-6.11	5.75
5	137.0455	145.8905	154.7246	-6.06	5.71
6	130.5528	138.9097	147.2544	-6.02	5.67
7	124.4033	132.3011	140.1856	-5.97	5.62
8	118.5769	126.0429	133.4946	-5.92	5.58
9	113.0550	120.1146	127.1591	-5.88	5.54
10	107.8202	114.4973	121.1586	-5.83	5.50
11	102.8560	109.1728	115.4734	-5.79	5.46
12	98.1470	104.1246	110.0855	-5.74	5.41
13	93.6787	99.3367	104.9778	-5.70	5.37
14	89.4378	94.7946	100.1342	-5.65	5.33
15	85.4114	90.4842	95.5398	-5.61	5.29
16	81.5875	86.3926	91.1805	-5.56	5.25
17	77.9551	82.5076	87.0430	-5.52	5.21
18	74.5034	78.8177	83.1150	-5.47	5.17

16. SENSOR PARAMETER

T [°C]	Rmin [KΩ]	Rnom [KΩ]	Rmax [KΩ]	DR(MIN)%	DR(MAX)%
19	71.2227	75.3122	79.3848	-5.43	5.13
20	68.1036	71.9808	75.8414	-5.39	5.09
21	65.1373	68.8141	72.4746	-5.34	5.05
22	62.3155	65.8032	69.2746	-5.30	5.01
23	59.6306	62.9395	66.2324	-5.26	4.97
24	57.0752	60.2152	63.3395	-5.21	4.93
25	54.6424	57.6227	60.5877	-5.17	4.89
26	52.3258	55.1551	57.9695	-5.13	4.85
27	50.1192	52.8058	55.4778	-5.09	4.82
28	48.0168	50.5684	53.1058	-5.05	4.78
29	46.0133	48.4371	50.8472	-5.00	4.74
30	44.1034	46.4046	48.6960	-4.96	4.71
31	42.2825	44.4711	46.6466	-4.92	4.66
32	40.5458	42.6261	44.6937	-4.88	4.63
33	38.8891	40.8668	42.8323	-4.84	4.59
34	37.3084	39.1890	41.0576	-4.80	4.55
35	35.7998	37.5883	39.3653	-4.76	4.51
36	34.3596	36.0609	37.7511	-4.72	4.48
37	32.9844	34.6030	36.2109	-4.68	4.44
38	31.6710	33.2113	34.7412	-4.64	4.40
39	30.4164	31.8823	33.3383	-4.60	4.37
40	29.2176	30.6130	31.9988	-4.56	4.33
41	28.0718	29.4004	30.7197	-4.52	4.29
42	26.9765	28.2417	29.4979	-4.48	4.26
43	25.9293	27.1342	28.3306	-4.44	4.22
44	24.9277	26.0755	27.2150	-4.40	4.19
45	23.9697	25.0632	26.1488	-4.36	4.15
46	23.0530	24.0950	25.1293	-4.32	4.12
47	22.1757	23.1688	24.1545	-4.29	4.08
48	21.3360	22.2826	23.2221	-4.25	4.05
49	20.5321	21.4345	22.3301	-4.21	4.01
50	19.7623	20.6226	21.4766	-4.17	3.98
51	19.0261	19.8468	20.6612	-4.14	3.94
52	18.3211	19.1040	19.8808	-4.10	3.91
53	17.6458	18.3926	19.1338	-4.06	3.87
54	16.9986	17.7113	18.4185	-4.02	3.84
55	16.3784	17.0537	17.7335	-3.96	3.83
56	15.7839	16.4332	17.0774	-3.95	3.77
57	15.2139	15.8338	16.4488	-3.92	3.74
58	14.6673	15.2592	15.8464	-3.88	3.71
59	14.1430	14.7083	15.2690	-3.84	3.67
60	13.6400	14.1799	14.7154	-3.81	3.64
61	13.1573	13.6730	14.1846	-3.77	3.61
62	12.6941	13.1868	13.6756	-3.74	3.57
63	12.2494	12.7202	13.1872	-3.70	3.54
64	11.8224	12.2723	12.7186	-3.67	3.51
65	11.4124	11.8424	12.2690	-3.63	3.48
66	11.0185	11.4295	11.8373	-3.60	3.45
67	10.6401	11.0331	11.4230	-3.56	3.41
68	10.2765	10.6522	11.0251	-3.53	3.38
69	9.9271	10.2863	10.6429	-3.49	3.35
70	9.5912	9.9348	10.2756	-3.46	3.32
71	9.2682	9.5968	9.9231	-3.42	3.29
72	8.9576	9.2720	9.5841	-3.39	3.26
73	8.6589	8.9597	9.2583	-3.36	3.23
74	8.3716	8.6594	8.9451	-3.32	3.19

16. SENSOR PARAMETER

T [°C]	Rmin [KΩ]	Rnom [KΩ]	Rmax [KΩ]	DR(MIN)%	DR(MAX)%
75	8.0951	8.3705	8.6440	-3.29	3.16
76	7.8290	8.0926	8.3544	-3.26	3.13
77	7.5730	7.8252	8.0758	-3.22	3.10
78	7.3264	7.5679	7.8078	-3.19	3.07
79	7.0891	7.3202	7.5499	-3.16	3.04
80	6.8605	7.0818	7.3018	-3.12	3.01
81	6.6403	6.8522	7.0629	-3.09	2.98
82	6.4282	6.6311	6.8329	-3.06	2.95
83	6.2239	6.4182	6.6115	-3.03	2.92
84	6.0269	6.2131	6.3982	-3.00	2.89
85	5.8371	6.0154	6.1928	-2.96	2.86
86	5.6542	5.8249	5.9949	-2.93	2.84
87	5.4777	5.6413	5.8042	-2.90	2.81
88	5.3076	5.4644	5.6205	-2.87	2.78
89	5.1435	5.2937	5.4433	-2.84	2.75
90	4.9853	5.1292	5.2726	-2.81	2.72
91	4.8326	4.9705	5.1079	-2.77	2.69
92	4.6852	4.8174	4.9492	-2.74	2.66
93	4.5430	4.6697	4.7960	-2.71	2.63
94	4.4058	4.5272	4.6483	-2.68	2.61
95	4.2733	4.3896	4.5058	-2.65	2.58
96	4.1453	4.2568	4.3683	-2.62	2.55
97	4.0218	4.1287	4.2355	-2.59	2.52
98	3.9024	4.0049	4.1074	-2.56	2.50
99	3.7872	3.8854	3.9837	-2.53	2.47
100	3.6758	3.7700	3.8643	-2.50	2.44
101	3.5661	3.6585	3.7512	-2.53	2.47
102	3.4601	3.5509	3.6419	-2.56	2.50
103	3.3577	3.4468	3.5362	-2.59	2.53
104	3.2588	3.3463	3.4341	-2.61	2.56
105	3.1632	3.2491	3.3353	-2.64	2.58
106	3.0708	3.1551	3.2398	-2.67	2.61
107	2.9816	3.0643	3.1475	-2.70	2.64
108	2.8953	2.9765	3.0582	-2.73	2.67
109	2.8118	2.8915	2.9717	-2.76	2.70
110	2.7311	2.8093	2.8881	-2.78	2.73
111	2.6531	2.7299	2.8072	-2.81	2.75
112	2.5776	2.6530	2.7289	-2.84	2.78
113	2.5046	2.5785	2.6531	-2.87	2.81
114	2.4340	2.5065	2.5798	-2.89	2.84
115	2.3656	2.4368	2.5087	-2.92	2.87
116	2.2995	2.3693	2.4400	-2.95	2.90
117	2.2354	2.3040	2.3733	-2.98	2.92
118	2.1734	2.2407	2.3088	-3.00	2.95
119	2.1134	2.1795	2.2463	-3.03	2.97
120	2.0553	2.1201	2.1858	-3.06	3.01
121	1.9991	2.0626	2.1271	-3.08	3.03
122	1.9446	2.0070	2.0702	-3.11	3.05
123	1.8918	1.9530	2.0151	-3.13	3.08
124	1.8406	1.9007	1.9617	-3.16	3.11
125	1.7911	1.8500	1.9099	-3.18	3.14
126	1.7430	1.8009	1.8597	-3.22	3.16
127	1.6965	1.7533	1.8110	-3.24	3.19
128	1.6514	1.7071	1.7638	-3.26	3.21
129	1.6076	1.6623	1.7180	-3.29	3.24
130	1.5652	1.6189	1.6736	-3.32	3.27

16. SENSOR PARAMETER

2. THE PARAMETER OF THE OTHER SENSOR IN INDOOR AND OUTDOOR UNIT:

($R_0=15K\pm 2\%$; $B0/100=3450K\pm 2\%$)

T [°C]	Rmin [KΩ]	Rnom [KΩ]	Rmax [KΩ]	DR(MIN)%	DR(MAX)%
-30	60.78	64.77	68.99	-6.16	6.12
-29	57.75	61.36	65.16	-5.88	5.83
-28	54.89	58.15	61.58	-5.61	5.57
-27	52.19	55.14	58.23	-5.35	5.31
-26	49.63	52.30	55.08	-5.11	5.05
-25	47.21	49.62	52.13	-4.86	4.81
-24	44.92	47.10	49.37	-4.63	4.60
-23	42.76	44.73	46.78	-4.40	4.38
-22	40.71	42.49	44.34	-4.19	4.17
-21	38.77	40.38	42.05	-3.99	3.97
-20	36.93	38.39	39.90	-3.80	3.78
-19	35.18	36.51	37.87	-3.64	3.59
-18	33.53	34.74	35.97	-3.48	3.42
-17	31.96	33.06	34.17	-3.33	3.25
-16	30.48	31.47	32.49	-3.15	3.14
-15	29.07	29.97	30.89	-3.00	2.98
-14	27.73	28.56	29.39	-2.91	2.82
-13	26.46	27.22	27.98	-2.79	2.72
-12	25.26	25.95	26.64	-2.66	2.59
-11	24.11	24.75	25.38	-2.59	2.48
-10	23.03	23.61	24.19	-2.46	2.40
-9	21.99	22.53	23.06	-2.40	2.30
-8	21.01	21.51	22.00	-2.32	2.23
-7	20.08	20.54	20.99	-2.24	2.14
-6	19.19	19.62	20.04	-2.19	2.10
-5	18.35	18.74	19.14	-2.08	2.09
-4	17.55	17.92	18.29	-2.06	2.02
-3	16.78	17.13	17.48	-2.04	2.00
-2	16.06	16.38	16.71	-1.95	1.97
-1	15.36	15.67	15.98	-1.98	1.94
0	14.70	15.00	15.29	-2.00	1.90
1	14.08	14.36	14.64	-1.95	1.91
2	13.48	13.75	14.02	-1.96	1.93
3	12.91	13.17	13.43	-1.97	1.94
4	12.36	12.62	12.87	-2.06	1.94
5	11.85	12.09	12.34	-1.99	2.03
6	11.35	11.59	11.83	-2.07	2.03
7	10.88	11.11	11.35	-2.07	2.11
8	10.43	10.66	10.89	-2.16	2.11
9	9.999	10.230	10.450	-2.26	2.11
10	9.590	9.816	10.040	-2.30	2.23
11	9.199	9.422	9.647	-2.37	2.33
12	8.826	9.047	9.269	-2.44	2.40
13	8.470	8.689	8.910	-2.52	2.48
14	8.129	8.347	8.567	-2.61	2.57
15	7.804	8.021	8.240	-2.71	2.66
16	7.493	7.709	7.928	-2.80	2.76
17	7.196	7.412	7.630	-2.91	2.86
18	6.912	7.127	7.346	-3.02	2.98
19	6.640	6.855	7.074	-3.14	3.10
20	6.381	6.595	6.815	-3.24	3.23
21	6.132	6.347	6.567	-3.39	3.35
22	5.894	6.109	6.330	-3.52	3.49

16. SENSOR PARAMETER

T [°C]	Rmin [KΩ]	Rnom [KΩ]	Rmax [KΩ]	DR(MIN)%	DR(MAX)%
23	5.667	5.882	6.103	-3.66	3.62
24	5.449	5.664	5.886	-3.80	3.77
25	5.240	5.456	5.678	-3.96	3.91
26	5.048	5.260	5.478	-4.03	3.98
27	4.864	5.072	5.286	-4.10	4.05
28	4.687	4.891	5.101	-4.17	4.12
29	4.517	4.717	4.924	-4.24	4.20
30	4.355	4.550	4.753	-4.29	4.27
31	4.198	4.390	4.589	-4.37	4.34
32	4.048	4.236	4.431	-4.44	4.40
33	3.904	4.089	4.280	-4.52	4.46
34	3.766	3.946	4.134	-4.56	4.55
35	3.663	3.810	3.994	-3.86	4.61
36	3.506	3.679	3.859	-4.70	4.66
37	3.383	3.552	3.729	-4.76	4.75
38	3.265	3.431	3.604	-4.84	4.80
39	3.152	3.314	3.484	-4.89	4.88
40	3.043	3.202	3.368	-4.97	4.93
41	2.938	3.094	3.257	-5.04	5.00
42	2.838	2.990	3.149	-5.08	5.05
43	2.741	2.890	3.046	-5.16	5.12
44	2.648	2.793	2.946	-5.19	5.19
45	2.558	2.701	2.850	-5.29	5.23
46	2.472	2.611	2.758	-5.32	5.33
47	2.389	2.525	2.669	-5.39	5.40
48	2.309	2.443	2.583	-5.49	5.42
49	2.232	2.363	2.500	-5.54	5.48
50	2.158	2.286	2.421	-5.60	5.58
51	2.087	2.212	2.344	-5.65	5.63
52	2.018	2.140	2.269	-5.70	5.69
53	1.952	2.072	2.198	-5.79	5.73
54	1.888	2.005	2.129	-5.84	5.82
55	1.827	1.941	2.062	-5.87	5.87
56	1.767	1.880	1.998	-6.01	5.91
57	1.710	1.820	1.936	-6.04	5.99
58	1.655	1.763	1.876	-6.13	6.02
59	1.602	1.707	1.818	-6.15	6.11
60	1.551	1.654	1.762	-6.23	6.13
61	1.502	1.602	1.709	-6.24	6.26
62	1.452	1.553	1.657	-6.50	6.28
63	1.409	1.505	1.606	-6.38	6.29
64	1.364	1.458	1.558	-6.45	6.42
65	1.322	1.413	1.511	-6.44	6.49
66	1.280	1.370	1.466	-6.57	6.55
67	1.241	1.328	1.422	-6.55	6.61
68	1.202	1.288	1.379	-6.68	6.60
69	1.165	1.249	1.339	-6.73	6.72
70	1.129	1.211	1.299	-6.77	6.77
71	1.095	1.175	1.261	-6.81	6.82
72	1.061	1.140	1.224	-6.93	6.86
73	1.029	1.106	1.188	-6.96	6.90
74	0.9977	1.073	1.153	-7.02	6.94
75	0.9676	1.041	1.120	-7.05	7.05
76	0.9385	1.011	1.088	-7.17	7.08
77	0.9104	0.9810	1.056	-7.20	7.10
78	0.8833	0.9523	1.026	-7.25	7.18

16. SENSOR PARAMETER

T [°C]	Rmin [KΩ]	Rnom [KΩ]	Rmax [KΩ]	DR(MIN)%	DR(MAX)%
79	0.8570	0.9246	0.9971	-7.31	7.27
80	0.8316	0.8977	0.9687	-7.36	7.33
81	0.8071	0.8717	0.9412	-7.41	7.38
82	0.7834	0.8466	0.9146	-7.47	7.43
83	0.7604	0.8223	0.8888	-7.53	7.48
84	0.7382	0.7987	0.8639	-7.57	7.55
85	0.7167	0.7759	0.8397	-7.63	7.60
86	0.6958	0.7537	0.8161	-7.68	7.65
87	0.6755	0.7322	0.7933	-7.74	7.70
88	0.6560	0.7114	0.7712	-7.79	7.75
89	0.6371	0.6913	0.7498	-7.84	7.80
90	0.6188	0.6718	0.7291	-7.89	7.86
91	0.6011	0.6530	0.7051	-7.95	7.39
92	0.5840	0.6348	0.6897	-8.00	7.96
93	0.5674	0.6171	0.6709	-8.05	8.02
94	0.5514	0.6000	0.6527	-8.10	8.07
95	0.5359	0.5835	0.6350	-8.16	8.11
96	0.5209	0.5675	0.6179	-8.21	8.16
97	0.5064	0.5519	0.6014	-8.24	8.23
98	0.4923	0.5369	0.5853	-8.31	8.27
99	0.4787	0.5224	0.5698	-8.37	8.32
100	0.4655	0.5083	0.5547	-8.42	8.36
101	0.4528	0.4946	0.5401	-8.45	8.42
102	0.4404	0.4814	0.5259	-8.52	8.46
103	0.4284	0.4685	0.5121	-8.56	8.51
104	0.4168	0.4561	0.4988	-8.62	8.56
105	0.4056	0.4440	0.4859	-8.65	8.62
106	0.3947	0.4323	0.4733	-8.70	8.66
107	0.3841	0.4210	0.4611	-8.76	8.70
108	0.3739	0.4100	0.4493	-8.80	8.75
109	0.3640	0.3993	0.4379	-8.84	8.81
110	0.3544	0.3890	0.4267	-8.89	8.84
111	0.3450	0.3789	0.4159	-8.95	8.90
112	0.3360	0.3692	0.4055	-8.99	8.95
113	0.3272	0.3597	0.3953	-9.04	9.01
114	0.3187	0.3505	0.3854	-9.07	9.06
115	0.3104	0.3416	0.3758	-9.13	9.10
116	0.3024	0.3330	0.3665	-9.19	9.14
117	0.2947	0.3246	0.3574	-9.21	9.18
118	0.2871	0.3164	0.3468	-9.26	8.77
119	0.2798	0.3085	0.3401	-9.30	9.29
120	0.2727	0.3008	0.33	-9.34	9.34

17. TROUBLESHOOTING

17. Troubleshooting

17.1 Trouble guide

Troubleshooting for Normal Malfunction

Trouble shooting	Possible Reason of Abnormality	How to Deal With
Air conditioner can not start up	<ol style="list-style-type: none"> 1. Power supply failure; 2. Trip of breaker or blow of fuse; 3. Power voltage is too low; 4. Setting of remote controller wrong; 5. Remote controller is short of power. 	<ol style="list-style-type: none"> 1. Check power supply circuit; 2. Measure insulation resistance to ground to see if there is any leakage; 3. Check if there is a defective contact or leak current in the power supply circuit; 4. Check and set remote controller again; 5. Change batteries.
The compressor starts or stops frequently	The air inlet and outlet has been blocked.	Remove block obstacles.
Poor cooling/heating	<ol style="list-style-type: none"> 1. The outdoor heat exchanger is dirty, such as condenser; 2. There are heating devices indoors; 3. The air tightness is not enough. People come in and out too frequently. 4. Block of outdoor heat exchanger; 5. Improper set of temperature. 	<ol style="list-style-type: none"> 1. Clean the heat exchanger of the outdoor unit, such as condenser ; 2. Remove heating devices; 3. Keep certain air tightness indoors; 4. Remove block obstacles; 5. Check and try to set temperature again.
Sound from deforming parts	During system starting or stopping, a sound might be heard. However, this is due to thermal deformation of plastic parts.	It is not abnormal, and the sound will disappear soon.
Water leakage	<ol style="list-style-type: none"> 1. Drainage pipe blocked or broken; 2. Wrap of refrigerant pipe joint is not close enough. 	<ol style="list-style-type: none"> 1. Change drainage pipe. 2. Re-wrap and make it tight.

17. TROUBLESHOOTING

When the air conditioner failure occurs, the fault code will displays on control board, wire remote controller or display panel.

How to check fault codes

Indoor Unit

(1) Fault codes indicated by wire remote controller (see figure below)

MOEDL:YXC-A01U(E)

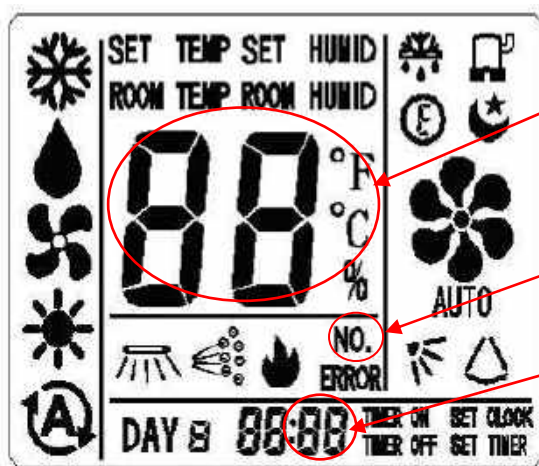

When display "FE", shows that the wire controller can't receive the signals of indoor unit control board, please check communication wires.

When failure occurs, this lamp light ON.

This number shows FAULT CODE.

MODEL:YXC-C01U/YXE-C01U/YXC-D01U/YXE-D01U(E)

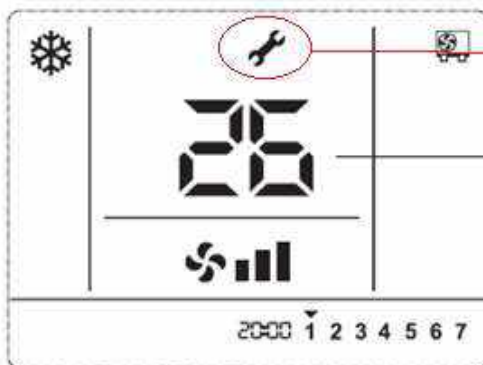

Indicate failure occur.

ERROR CODE

When the airconditioner is malfunction,  will display on the LCD, and error codes will appear and blink.

FIG.2 FAULT CODE DISPLAY ON WIRE REMOT CONTROLLER

(2) Error codes indicated on display panel.(see figure below)

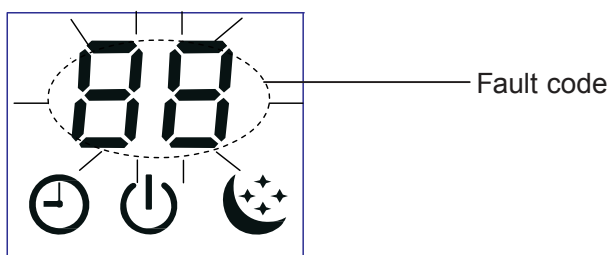

17. TROUBLESHOOTING

(3) Fault codes indicated by LED lamps on display panel

Lamp RUN(LED2 ,red) and Lamp DEFROST (LED5 ,green) flashing, Lamp RUN display fault code ten digit number, lamp DEFROST display fault code single digit number (as shown fig. below).

For example, fault code 36: led RUN& defrost flash 3 times at the same time, and led DEFROST continue flash 3 times,reports No. 36 fault.

Display panel

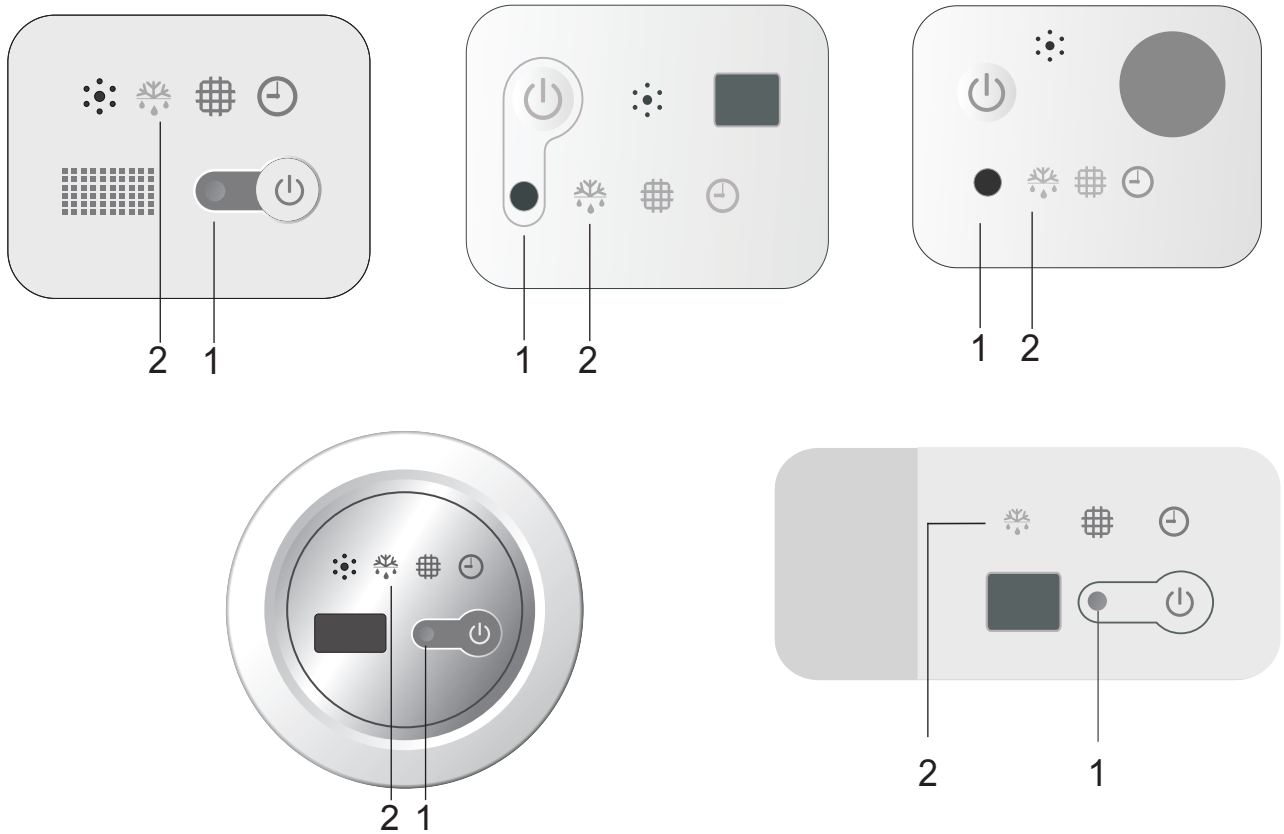

- 1 Run indicator (Red)
Indicates the fault code ten digital number.
- 2 Defrost indicator (Green)
Indicates the fault code single digit number.

LED FLASH CONTROL: flash 300ms(T1), off 300ms(T2), after 2000ms(T3)fault code repeat displays. (as shown below)

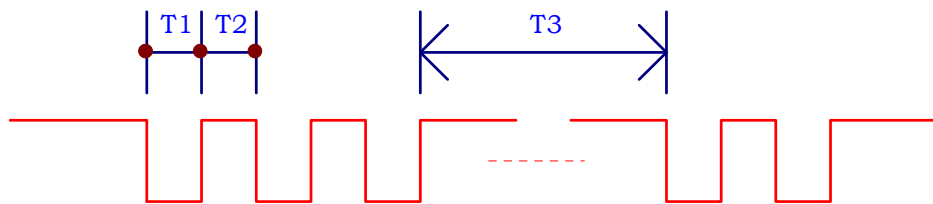

FIG.2 LED flash control

17. TROUBLESHOOTING

Outdoor Unit

9K~30K

DC-Inverter unitary (Main control board upside-down)

Fault code displays by LED lamps on outdoor main control board.

There are 3 LED lamps on control board, LED1, LED2 and LED3.

LED1 indicate fault code ten digit number, LED2 indicate fault code single digit number and LED3 indicate outdoor drive control fault .

When LED3 is off, LED1 and LED 2 indicate main control failure code.

When LED3 is on, LED1 and LED 2 indicate drive control failure code.

When LED3 is flickering and LED1, LED 2 are all off, indicate compressor is preheating .

Failures display with 5s interval. It means LED will off 5s to report next failure code .

System protect codes display method is the same with main control failure code .

LED lamps will off when there is no failure, protect or preheating.

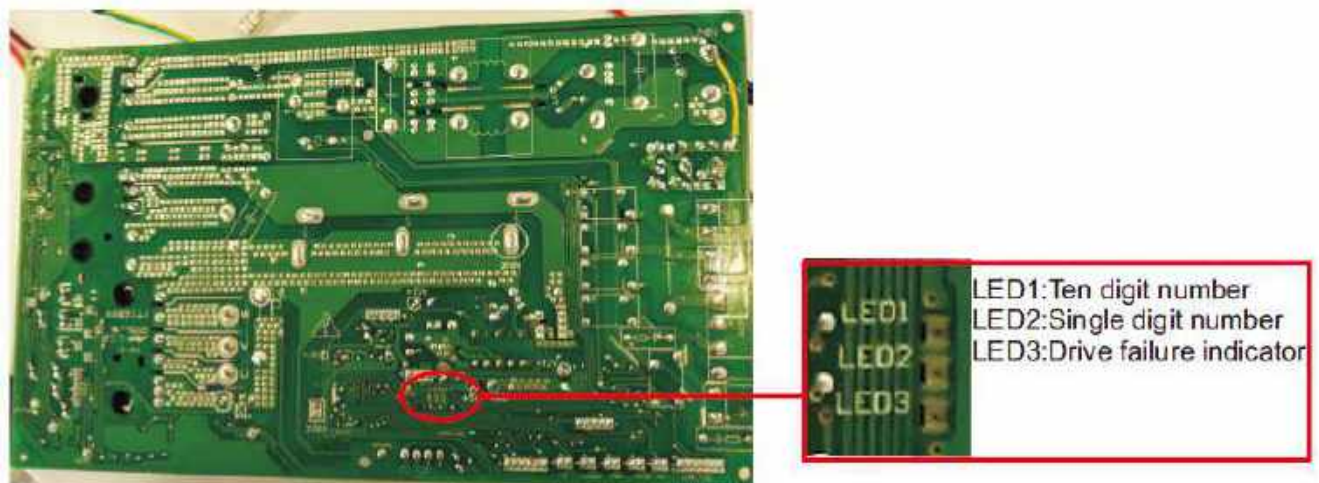

17. TROUBLESHOOTING

For example, outdoor main control fault 32:

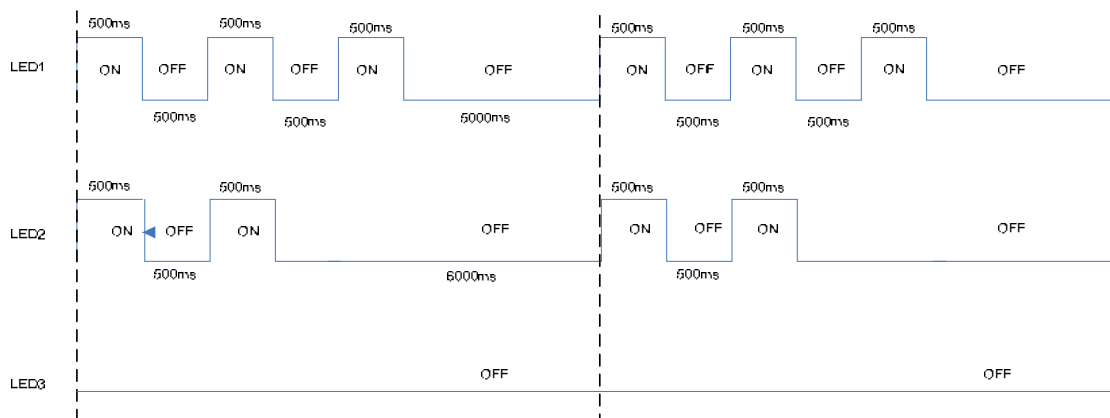

For example, outdoor drive fault 32:

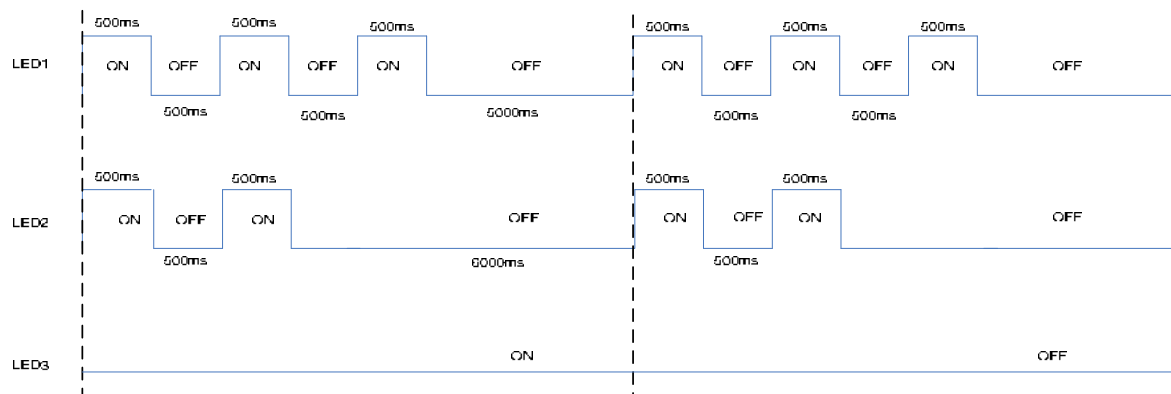

17. TROUBLESHOOTING

36K~60K

Main control fault display

Fault code will display on digital tube board.

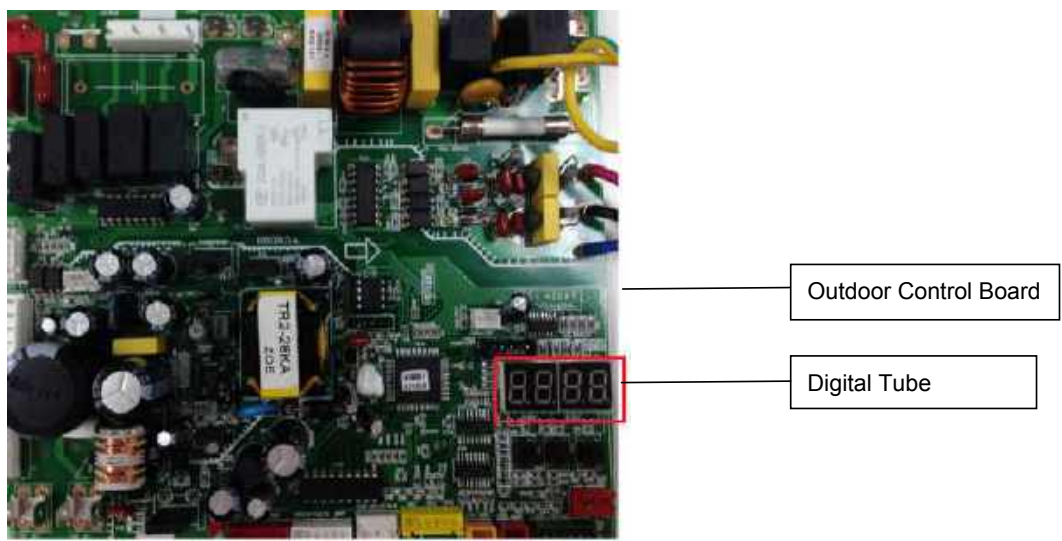

E shows failure occur

Display ERROR Code

Drive fault code display

The lamp of drive board flash shows failure occur.

17. TROUBLESHOOTING

Drive fault code display

The lamp of drive board flash shows failure occur.
The drive failure lamp flicking times shows the failure code.

Single phase models:

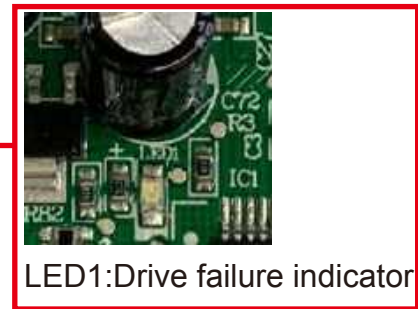

LED1: Drive failure indicator

3-phase models:



LED1, LED3:
Power lamp

LED2: Drive failure indicator

The drive failure lamp flicking times shows the failure code.

17. TROUBLESHOOTING

17.2 Fault codes

The following is the fault code table of outdoor.

Sheet 1 Outdoor Fault Code

Fault code	Fault Description	Possible Reason of Abnormality	How to Deal With	REMARKS
1	Outdoor ambient temperature sensor fault	<ol style="list-style-type: none"> 1.The outdoor ambient temperature sensor connect loose; 2.The outdoor ambient temperature sensor is failure; 3.The sampling circuit is failure 	<ol style="list-style-type: none"> 1.Reconnect the outdoor ambient temperature sensor; 2.Replace the outdoor ambient temperature sensor components; 3.Replace the outdoor control board components. 	
2	Outdoor coil temperature sensor fault	<ol style="list-style-type: none"> 1.The outdoor coil temperature sensor connect loose; 2.The outdoor coil temperature sensor is failure; 3.The sampling circuit is failure 	<ol style="list-style-type: none"> 1.Reconnect the outdoor coil temperature sensor; 2.Replace the outdoor coil temperature sensor components; 3.Replace the outdoor control board components. 	
3	The unit over-current turn off fault	<ol style="list-style-type: none"> 1. Control board current sampling circuit is failure; 2. The current is over high because of the supply voltage is too low 3. The compressor is blocked 4. Overload in cooling mode 5. Overload in heating mode 	<ol style="list-style-type: none"> 1. Replace the electrical control board components; 2. Normally protection 3. Replace the compressor 4. Please see the Note 3 5. Please see the Note 4 	
4	EEprom Data error	<ol style="list-style-type: none"> 1.EE components is failure; 2.EE components control circuit failure; 3.EE components insert incorrect 	<ol style="list-style-type: none"> 1.Replace the EE components; 2.Replace the outdoor control board components; 3.Reassembly the EE components. 	
5	Cooling freezing protection (the indoor coil temperature is too low) or heating overload (indoor coil temperature is too high)	<ol style="list-style-type: none"> 1.The indoor unit can not blow air normally; 2.The room temperature is too low in cooling mode or the room temperature is too high in heating; 3.The filter is dirty; 4.The duct resistance is too high to result in low air flow; 5.The setting fan speed is too low; 6. The indoor unit is not standard installed, air inlet is too near with air outlet . 	<ol style="list-style-type: none"> 1.Check the indoor fan, indoor fan motor and evaporator whether normally; 2. Normally protection; 3.Clean the filter; 4.Check the volume control valve, duct length etc.; 5.Set the speed with high speed; 6.Reinstall the indoor unit refer to the user manual to change the distance between the indoor unit and the wall or ceiling. 	
7	The communication fault between the indoor unit and outdoor unit	<ol style="list-style-type: none"> 1.The connection cable connect wrong between the indoor unit and outdoor unit; 2.The communication cable connect loose; 3.The communication cable is fault; 4.The indoor control board is fault; 5.The outdoor control board is fault; 6.Communication circuit fuse open; 7.The specification of communication cable is incorrect. 	<ol style="list-style-type: none"> 1.Reconnect the connection cable refer to the wiring diagram; 2.Reconnect the communication cable; 3.Replace the communication cable; 4.Replace the indoor control board; 5.Replace the outdoor control board; 6.Check the communication circuit, adjust the DIP switch and the short-circuit fuse. 7.Choose suitable communication cable refer to the user manual 	

17. TROUBLESHOOTING

Fault code	Fault Description	Possible Reason of Abnormality	How to Deal With	REMARKS
12	voltage absent phase	Three-phase power is abnormal; The outdoor wiring connect wrong; The outdoor control board is failure.	1. Normally protection 2. Check the wiring connection refer to the wiring diagram; 3. Replace the outdoor control board	Application of three-phase power supply models
13	Compressor overheat protector device	1. The wiring of the overload protector connect loose. 2. The overload protector is failure . 3. The refrigerant is not enough; 4. The installation pipe is too long than normal, but not add the enough refrigerant; 5. The expansion valve is failure; 6. The outdoor control board is failure	1. Reconnect the wiring of the overload protector; 2. Replace the overload protector; 3. Check the welding point of the unit to confirm whether it is leakage, and then recharge the refrigerant; 4. Add the refrigerant; 5. Replace expansion valve; 6. Replace the outdoor control board.	
14	the high pressure switch operate or the unit turn off for high pressure protection	1.The wiring of the high pressure protector connect loose; 2.The high pressure protector is failure; 3.The outdoor control board is abnormal; 4. Overload in cooling; 5. Overload in heating.	1.Reconnect the wiring the high pressure protector; 2. Replace the high pressure protector; 3. Replace the outdoor control board; 4. Please refer to the Note 3; 5. Please refer to the Note 4.	Applied to models with high pressure switch or pressure sensor
15	the low pressure switch protection or the unit turn off for low pressure protection	1. The wiring of the low pressure switch connect loose; 2. The low pressure switch is failure; 3.The refrigerant is not enough; 4.The expansion valve failure in heating mode; 5.The outdoor control board is abnormal.	1. Reconnect the wiring of the low pressure switch; 2. Replace the low pressure switch; 3.Check the welding point to confirm whether the unit is leakage, and then add some refrigerant; 4. Replace the expansion valve; 5. Replace the outdoor control board.	Applied to models with low pressure switch or pressure sensor
16	overload protection in cooling mode	System overload	Please refer to the Note 3.	
17	Discharge temperature sensor fault	1.The wiring of the discharge temperature sensor connect loose; 2.The discharge temperature sensor is failure; 3.The sampling circuit is abnormal.	1.Reconnect the wiring of the discharge temperature sensor; 2.Replace the discharge temperature sensor; 3.Replace the outdoor control board.	
18	AC voltage is abnormal	1.The AC voltage>275V or <160V. 2.The AC voltage of sampling circuit on the driver board is abnormally	1. Normally protection, please check the supply power; 2. Replace the driver board.	
19	Suction temperature sensor fault	1.The wiring of the suction temperature sensor connect loose; 2. The suction temperature sensor is failure; 3. The sampling circuit is abnormally	1.Reconnect the wiring of the suction temperature sensor; 2.Replace the suction temperature sensor; 3.Replace the outdoor control board.	
22	The defrosting sensor fault	1.The wiring of the defrosting sensor connect loose; 2.The defrosting sensor is failure; 3.The sampling circuit is abnormally	1. Reconnect the wiring of the defrosting sensor; 2. Replace the defrosting sensor; 3. Replace the outdoor control board.	
45	IPM fault	There are many reasons for this failure, If you need further analysis, fault code of the driver board is needed by watching the driver board fault led. Analysis can be further to know why and how to operate. Specific see table 5, table 6.	See attached "analysis of the driving board fault".	

17. TROUBLESHOOTING

Fault code	Fault Description	Possible Reason of Abnormality	How to Deal With	REMARKS
46	IPM and control board communication fault	<ol style="list-style-type: none"> 1.The cable between the control board and the driver board connect loose; 2.The cable between the control board and the driver board is failure; 3.The driver board is failure ; 4.The control board is failure. 	<ol style="list-style-type: none"> 1.Reconnect the cable between the control board and the driver board; 2.Replace the communication cable between the control board and the driver board; 3.Replace the driver board; 4.Replace the control board. 	
47	Discharge temperature too high fault	<ol style="list-style-type: none"> 1. The refrigerant of the unit is not enough; 2.The refrigerant of the unit is not enough due to add the length of the installation pipe 3.Throttling service is failure; 4.The outdoor ambient temperature is too high 	<ol style="list-style-type: none"> 1.Check the welding point to confirm whether the unit has exist leakage point, and then add some refrigerant. 2.Add some refrigerant refer to the installation user manual; 3.Replace the throttling service (such as capillary, expansion valve) 4. Normally protection. 	
48	the outdoor DC fan motor fault (upper fan motor)	<ol style="list-style-type: none"> 1.The wiring of the up DC fan motor connect loose; 2. The cord of the up DC fan motor is failure; 3.The up DC fan motor is failure; 4. The drive circuit of the up DC fan motor is failure; 5. The outdoor fan has been blocked. 	<ol style="list-style-type: none"> 1.Reconnect the wiring of the up DC fan motor; 2.Replace the up DC fan motor; 3. Replace the up DC fan motor; 4.Replace the driver board of the fan motor; 5. Check the outdoor fan and ensure the outdoor fan can run normally. 	
49	the outdoor DC fan motor fault (down fan motor)	<ol style="list-style-type: none"> 1.The wiring of the down DC fan motor connect loose; 2.The cord of the down DC fan motor is failure; 3. The down DC fan motor is failure; 4. The drive circuit of the down DC fan motor is failure; 5. The outdoor fan has been blocked. 	<ol style="list-style-type: none"> 1. Reconnect the wiring of the down DC fan motor; 2. Replace the down DC fan motor; 3. Replace the down DC fan motor; 4. Replace the driver board of the fan motor; 5. Check the outdoor fan and ensure the outdoor fan can run normally. 	
91	The unit turn off due to the IPM board over heating fault	<ol style="list-style-type: none"> 1.The outdoor ambient is too high; 2.The speed of the out fan motor is too low if the fan motor is AC fan motor; 3.The outdoor unit has been installed without standard; 4.The supply power is too low. 	<ol style="list-style-type: none"> 1. Normally protection; 2. Check the fan capacitor, and replace the fan capacitor if it is failure; 3. Reinstalled the outdoor unit refer to the installation user manual; 4.Normally protection. 	
96	the refrigerant of the unit is not enough fault	The refrigerant of the unit is not enough	Discharge the refrigerant and charge the refrigerant refer to the rating label	
97	4-way valve commutation failure fault	<ol style="list-style-type: none"> 1.The wiring of the 4-way valve coil connect loose; 2.The 4-way valve coil is failure; 3.The 4-way valve is failure; 4.The driver board of the 4-way valve is failure 	<ol style="list-style-type: none"> 1. Reconnect the wiring of the 4-way valve; 2. Replace the 4-way valve coil; 3. Replace the 4-way valve; 4.Replace the driver board of the 4-way valve. 	

17. TROUBLESHOOTING

The following is the fault code table of indoor.

Sheet 2 Indoor Fault code

Fault code	Fault Description	Possible Reason of Abnormality	How to Deal With	Remarks
51	Drainage protection	<ol style="list-style-type: none"> 1. The water level of the drain pan exceed safe level; 2. The cable of the water level switch connect loose; 3. The water level switch is failure; 4. The control board is failure. 	<ol style="list-style-type: none"> 1.1 Check whether there are something to block the drain hose or the height of the drain hose is too high; 1.2 Check the water pump and replace the water pump if the water pump is failure; 2. Reconnect the cable of the water level switch refer to the wiring diagram; 3. Replace the water level switch; 4. Replace the control board. 	
55	Mode Conflict Fault	The user set the conflicting mode for more than two indoor units	Reset the operate mode for the indoor unit, for the one outdoor unit, the user should avoid to set the conflicting operate mode with the indoor units.	
64	Communication between Indoor & Outdoor unit Fault	<ol style="list-style-type: none"> 1. The connection cable between the indoor unit and the outdoor unit connect wrong; 2. The communication cable connect loose; 3. The communication cable between the indoor unit and the outdoor unit is failure or the cable between the indoor control board to terminal is failure or the cable between the outdoor control board to the terminal is failure; 4. The indoor control board is failure; 5. The outdoor control board is failure. 	<ol style="list-style-type: none"> 1. Reconnect the connection cable refer to the indoor and outdoor wiring diagram; 2. Reconnect the communication cable refer to the indoor and outdoor wiring diagram; 3. Replace the communication cable refer to the indoor and outdoor wiring diagram; 4. Replace the indoor control board; 5. Replace the outdoor control board. 	
71	Indoor unit zero check fault	<ol style="list-style-type: none"> 1. The motor wire is loosen; 2. The motor connect is open; 3. The motor is failure; 4. Control board is failure. 5. Indoor fan is baffled. 	<ol style="list-style-type: none"> 1. Replace the motor wire and make sure the wire connect is well; 2. Replace the motor wire; 3. Change the motor; 4. Change the indoor control board; 5. Check and elimination of fan motor rotation. 	
72	Indoor fan motor fault	<ol style="list-style-type: none"> 1. The cable of the indoor fan motor connect loose; 2. The cable of the indoor fan motor is failure; 3. The indoor fan motor is failure; 4. The indoor control board is failure. 	<ol style="list-style-type: none"> 1. Reconnect the cable of the fan motor; 2. Replace the cable of the fan motor; 3. Replace the fan motor; 4. Replace the indoor control board; 5. Check the indoor fan and ensure the indoor fan can run normally. 	
73	Indoor EEPROM Data 1 fault	<ol style="list-style-type: none"> 1. Indoor EE components is failure; 2. The control circuit of the EE components is failure; 3. The EE components has been inserted with opposite direction. 	<ol style="list-style-type: none"> 1. Replace the EE components; 2. Replace the indoor control board; 3. Reassembly the EE components of the indoor control board. 	

17. TROUBLESHOOTING

Fault code	Fault Description	Possible Reason of Abnormality	How to Deal With	Remarks
74	Indoor EEPROM Data 2 error	EE in MCU is failure, the unit can run, but the function user has set is ineffective.	Replace EE data in MCU.	
81	Indoor ambient Temperature Sensor Fault	<ol style="list-style-type: none"> 1. The cable of the room temperature sensor connect loose; 2. The room temperature sensor is failure; 3. The sampling circuit is abnormally 	<ol style="list-style-type: none"> 1. Reconnect the cable of the room temperature sensor; 2. Replace the room temperature sensor; 3. Replace the indoor control board. 	
83	Evaporator Middle Temperature Sensor Fault	<ol style="list-style-type: none"> 1. The cable of the coil temperature sensor of the evaporator is failure; 2. The coil temperature sensor of the evaporator is failure; 3. The sampling circuit is abnormally 	<ol style="list-style-type: none"> 1. Reconnect the cable of the coil temperature sensor of the evaporator; 2. Replace the coil temperature sensor of the evaporator; 3. Replace the indoor control board. 	
FE (254)	Communication between main control board & Wiring remote controller Fault (display on wiring remote controller)	<ol style="list-style-type: none"> 1. The wiring between the wiring controller to the indoor control board connect loose; 2. The sequence of the wiring between the wiring controller to the indoor control board is wrong; 3. The wiring between the wiring controller to the indoor control board is failure; 4. The wiring controller is failure; 5. The indoor control board is abnormally. 	<ol style="list-style-type: none"> 1. Reconnect the wiring between the wiring controller to the indoor control board; 2. Replace the wiring between the wiring controller to the indoor control board; 3. Replace the wiring between the wiring controller to the indoor control board; 4. Replace the wiring controller; 5. Replace the indoor control Board. 	
ER	Communication between main control board & display board Fault (displays on display board)	<ol style="list-style-type: none"> 1. The wiring between the display board to the indoor control board connect loose; 2. The sequence of the wiring between the display board to the indoor control board is wrong; 3. The wiring between the display board to the indoor control board is failure; 4. The display board is failure; 5. The indoor control board is failure. 	<ol style="list-style-type: none"> 1. Reconnect the between the display board to the indoor control board; 2. Replace the wiring between the display board to the indoor control board; 3. Replace the wiring between the display board to the indoor control board; 4. Replace the display board; 5. Replace the indoor control board. 	

17. TROUBLESHOOTING

NOTE 1:

If the indoor unit can not turn on or the indoor unit turn off itself after 30s, at the same time the unit do not display the fault code, please check the fire and the socket of the control board.

Note 2:

If the indoor unit display the 75,76,77,78 fault code after you turn on the unit, please check the TEST seat of the indoor control board or the TEST detection circuit whether exists short circuit.

Note 3:Overload in cooling mode

overload in cooling mode		
sr.	The root cause	Corrective measure
1	The refrigerant is excessive	Discharge the refrigerant, and recharge the refrigerant refer to the rating label
2	The outdoor ambient temperature is too high	Please use within allowable temperature range
3	The air outlet and air inlet of the outdoor unit is short-circuit	Adjust the installation of the outdoor unit refer to the user manual
4	The outdoor heat exchanger is dirty, such as condenser	Clean the heat exchanger of the outdoor unit, such as condenser
5	The speed of the outdoor fan motor is too low	Check the outdoor fan motor and fan capacitor
6	The outdoor fan is broken or the outdoor fan is blocked	Check the outdoor fan
7	The air inlet and outlet has been blocked	Remove the blocked thing
8	The expansion valve or the capillary is failure	Replace the expansion valve or the capillary

Note 4:Over load in heating mode

Overload in heating mode		
sr.	The root cause	Corrective measure
1	The refrigerant is excessive	Discharge the refrigerant, and recharge the refrigerant refer to the rating label
2	The indoor ambient temperature is too high	Please use within allowable temperature range
3	The air outlet and air inlet of the indoor unit is short-circuit	Adjust the installation of the indoor unit refer to the user manual
4	The indoor filter is dirty	Clean the indoor filter
5	The speed of the indoor fan motor is too low	Check the indoor fan motor and fan capacitor
6	The indoor fan is broken or the outdoor fan is blocked	Check the indoor fan
7	The air inlet and outlet has been blocked	Remove the blocked thing
8	The expansion valve or the capillary is failure	Replace the expansion valve or the capillary

17. TROUBLESHOOTING

Sheet 5 Drive Fault code (9K~30K)

Fault code	Fault Description	Possible Reason of Abnormality	How to Deal With
1	Inverter DC voltage overload fault	1. Power supply input too high or too low; 2. Driver board fault.	1. Check power supply 2. Change driver board.
2	Inverter DC low voltage fault		
3	Inverter AC current overload fault		
4	Out-of-step detection	1. Compressor phase lost ; 2. Bad driver board components ; 3. The compressor insulation fault	1. Check compressor wire connect ; 2. Change driver board ; 3. Change compressor.
5	Loss phase detection fault (speed pulsation)		
6	Loss phase detection fault (current imbalance)		
7	Inverter IPM fault (edge)	1. System overload or current overload; 2. Driver board fault. 3. Compressor oil shortage, serious wear of crankshaft ; 4. The compressor insulation fault.	1. Check the system . 2. Change driver board; 3. Change the compressor; 4. Change the compressor.
8	Inverter IPM fault (level)		
9	PFC_IPM IPM fault (edge)		
10	PFC_IPM IPM fault (level)		
11	PFC power detection of failure	1. The power supply is not stable; 2. The instantaneous power failure; 3. Driver board failure.	1. Check the power supply. 2. Not abnormal. 3. Change the driver board.
12	PFC overload current detection of failure.	1. System overload, current too high; 2. Driver board failure; 3. PFC failure.	1. Check the system; 2. Change the driver board; 3. Change the PFC.
13	DC voltage detected abnormal .	1. Input voltage is too high or too low; 2. Driver board failure ;	1. Check the power supply. 2. Change the driver board.
14	PFC LOW voltage detected failure.		
15	AD offset abnormal detected failure.	Driver board failure.	Change the driver board.
16	Inverter PWM logic set fault.		
17	Inverter PWM initialization failure		
18	PFC_PWM logic set fault.		
19	PFC_PWM initialization fault.		
20	Temperature abnormal.		
21	Shunt resistance unbalance adjustment fault		
22	Communication failure.	1. Communication wire connect not well. 2. Driver board failure. 3. Control board failure.	1. Check the wiring. 2. Change the driver board. 3. Change the control board.
23	Motor parameters setting of failure	Initialization abnormal.	Reset the power supply.
25	EE data abnormal	Driver board EEPROM abnormal	1. Change EEPROM ; 2. Change driver board.
26	DC voltage mutation error	1. Power input changes suddenly 2. Driver board failure	1. Check power supply, to provide stable power supply; 2. Change driver board.
27	D axis current control error	1. System overload, phase current is too high; 2. Driver board failure	1. Check system if normally. 2. Check stop valve if is open; 3. Change driver board.
28	q axis current control error	1. System overload, phase current is too high ; 2. Driver board failure	1. Check system if normally. 2. Check stop valve if is open; 3. Change driver board.
29	Saturation error of d axis current control integral	1. System overload suddenly; 2. Compressor parameter not suitable; 3. Driver board failure	1. Check system if normally. 2. Check stop valve if is open; 3. Change driver board.
30	Saturation error of q axis current control integral	1. System overload suddenly; 2. Compressor parameter not suitable; 3. Driver board failure.	1. Check system if normally. 2. Check stop valve if is open; 3. Change driver board.

17. TROUBLESHOOTING

Sheet6 DriveFault Code (36K~60K)

Fault code	Fault Description	Possible Reason of Abnormality	How to Deal With
1	Q axis current detection, step out of failure	1. compressor wire connect not well; 2. Bad driver board components; 3. Compressor start load is too large; 4. Compressor demagnetization; 5. Compress or oil shortage serious wear of crankshaft.; 6. The compressor insulation fault	1. Check compressor wire; 2. Change driver board ; 3. Turn on the machine after pressure balance again; 4. Change Compressor; 5. Change the Compressor; 6. Change the Compressor.
2	Phase current detection, out of step	1.Compressor voltage default phase; 2.Bad driver board components; 3.The compressor insulation fault	1.Check compressor wire connection; 2.Change the driver board; 3. Change the Compressor.
3	Initialization, phase current imbalance	Bad driver board components.	Change driver board .
4	Speed estimation, step out of failure	1.Bad driver board components; 2.Compressor shaft clamping; 3.The compressor insulation fault.	1.Change driver board ; 2.Change the Compressor ; 3.Change the Compressor .
5	IPM FO output fault	1. System overload or current overload. 2. Driver board fault; 3.Compressor oil shortage,serious wear of crankshaft; 4.The compressor insulation fault.	1.Check the air-conditioner system; 2.Change the driver board; 3.Change the Compressor; 4. Change the Compressor.
6	Communication between driver board and control board fault	1.Communication wire connect not well; 2. Driver board fault; 3. Control board fault;	1. Check compressor wire connect. 2. Change the driver board; 3. Change the control board ;
7	AC voltage,overload voltage	1. Supply voltage input too high or too low; 2. Driver board fault;	1.Check power supply; 2.Change the driver board;
8	DC voltage,overload voltage	1. Supply voltage input too high ; 2. Driver board fault;	1. Check power supply; 2. Change the driver board;
9	AC voltage imbalance	Driver board fault;	Change the driver board;
10	The PFC current detection circuit fault before compressor is ON	Bad driver board components;	Change the driver board
11	AC voltage supply in outrange	1.Power supply abnormal, power frequency out of range; 2.Driver board fault;	1. Check the system; 2. Change the driver board;
12	Products of single-phase PFC over-current, FO output low level	1. System overload, current too large; 2. Driver board fault; 3. PFC fault.	1. Check the system; 2. Change the driver board; 3. Change PFC.
	Inverter over current (3-phase power supply air conditioners)	1. System overload, current too large; 2. Driver board fault; 3. Compressor oil shortage, serious wear of crankshaft; 4. The compressor insulation fault.	1. Check the system; 2. Change the driver board; 3. Change the Compressor; 4. Change the Compressor.
13	Inverter over current	1. System overload, current too large; 2. Driver board fault; 3. Compressor oil shortage,serious wear of crankshaft; 4.The compressor insulation fault.	1. Check the system; 2. Change the driver board; 3. Change the Compressor; 4. Change the Compressor.
14	PFC over current(single-phase air-conditioner)	1. System overload, current too large; 2. Driver board fault; 3. PFC fault.	1. Check the system; 2. Change the driver board; 3. Change PFC.
	Phase imbalance or phase lacks or the instantaneous power failure (only for 3-phase power supply air conditioners)	1.3-Phase voltage imbalance; 2.The 3-phase power supply phase lost; 3. Power supply wiring wrong; 4. Driver board fault.	1, Check the power supply; 2. Check the power supply; 3. Check the power supply wiring connect; 4.Change the driver board.
15	The instantaneous power failure detection	1.The power supply is not stable ; 2.The instantaneous power failure ; 3.Driver board fault;	1. Check the power supply; 2. Not fault; 3. Change the driver board.

17. TROUBLESHOOTING

Fault code	Fault Description	Possible Reason of Abnormality	How to Deal With
16	Low DC voltage 200V	1. Voltage input too low; 2. Drive board fault.	1. Check the power supply. 2. Change the driver board.
18	Driver board read EE data error	1. EEPROM has no data or data error; 2. EEPROM circuit fault.	1. Change EEPROM component; 2. Change the driver board.
19	PFC chip receive data fault	Abnormal communication loop	Change the drive board.
20	PFC soft start abnormal	Abnormal PFC drive loop	Change the drive board.
21	The compressor drive chip could not receive data from PFC chip.	Communication loop fault.	Change the drive board.

18. CHECKING COMPONENTS

18. Checking components

18.1 Check refrigerant

system TEST SYSTEM FLOW

Conditions: ① Compressor is running.

② The air condition should be installed in good ventilation.

Tool: Pressure Gauge

Technique: ① see ② feel ③ test

SEE ---- Tube defrost.

FEEL ---- The difference between tube's temperature.

TEST ---- Test pressure.

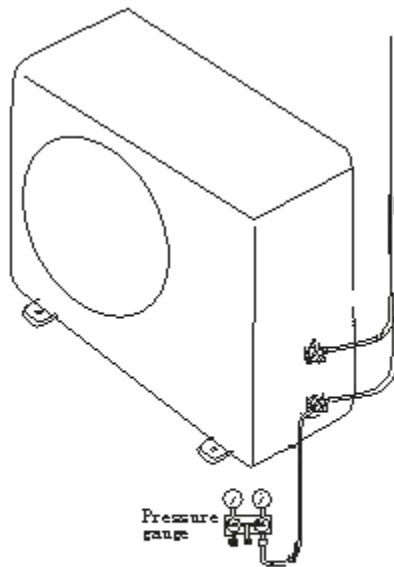

18. CHECKING COMPONENTS

Test system flow

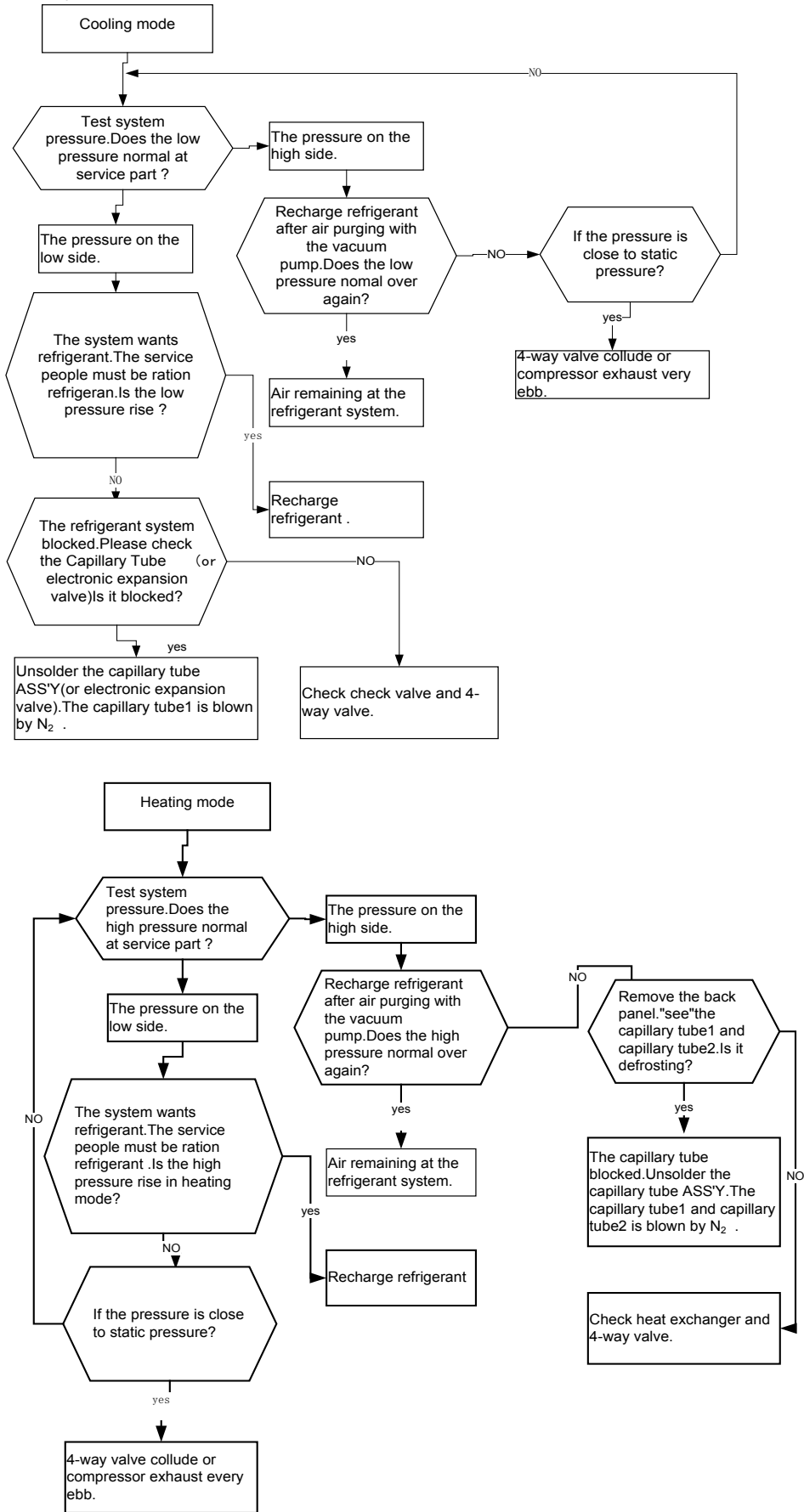

18. CHECKING COMPONENTS

18.2 Check parts unit

1. Indoor unit fan motor

Duct motor model (DC motor)

9K/12K: SIC-68CVL-F140-1

18K/24K: SIC-68CVL-F160-2

30K/36K: SIC-101CW-F1210-1

48K/60K: SIC-101CW-F1250-4

Cassette motor model(DC motor)

9K/12K: SIC-62FW-D857-15

18K: SIC-62FV-F130-3

24K/30K/36K: EHDS50AQH

42K/48K/60K:SIC-72FW-D8124-2B

Ceiling & Floor (DC motor)

18K/24K: SIC-70CW-F1100-6

30K/36K: SIC-70CW-F1140-3

42K/48K/60K: SIC-101CW-F1181-2

Console

Motor model : SIC-39CE-F130-1

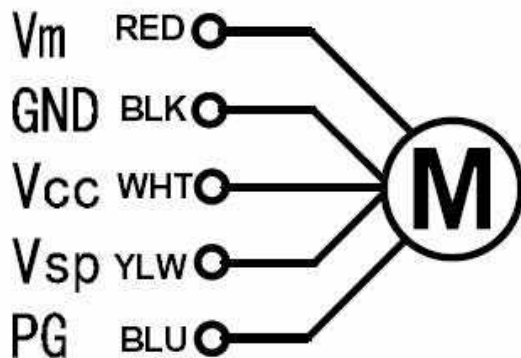

Test in resistance.

TOOL: Multimeter.

Test the resistance of the main winding. The indoor fan motor is fault if the resistance of main winding 0(short circuit)or ∞ (open circuit) .

Test in voltage

TOOL: Multimeter.

Insert screwdriver into to rotate indoor fan motor slowly for 1 revolution or over, and measure voltage "YELLOW" and "GND" on motor. The voltage repeat 0V DC and 5V DC.

Notes:

Please don't hold motor by lead wires.

Please don't plug IN/OUT the motor connector while power ON.

Please don't drop hurl or dump motor against hard material. Malfunction may not be observed at early stage after such shock. But it may be found later, this type of mishandling void our warranty.

18. CHECKING COMPONENTS

2. Outdoor unit fan motor

DC motor

9K/12K/18K: SIC-52FV-F130-3

24K: SIC-61FW-F161-1

30K: SIC-81FW-F1138-1

36K: SIC-71FW-D8121-1

48K/60K: SIC-71FW-D8121-1+ SIC-71FW-D8121-2

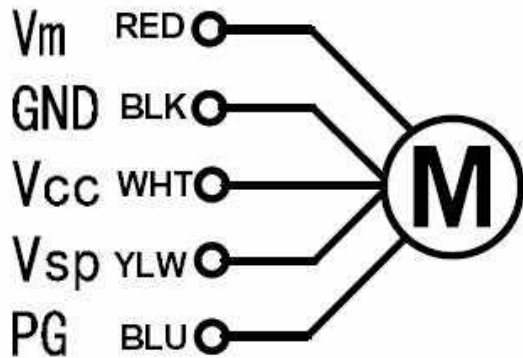

3. Compressor

COMPRESSOR EXAMINE AND REPAIR

9K: KSK103D59UFZ

18K: KTN150D42UFZ

24K/30K: KTM240D57UMT

48K: KTF400D64UMT

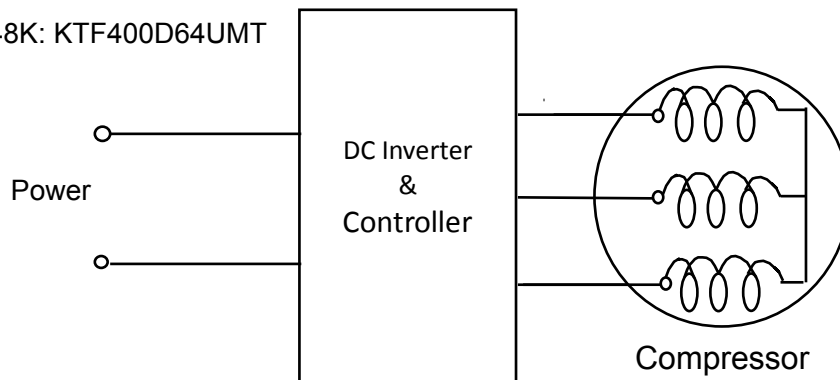

12K: KSN108D43UFZA

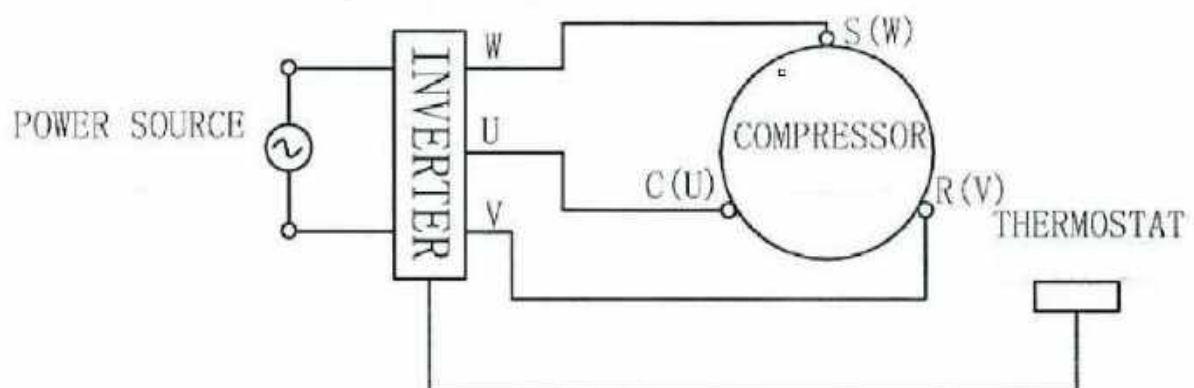

18. CHECKING COMPONENTS

36K: KTF310D43UMT

60K: KTQ420D1UMU

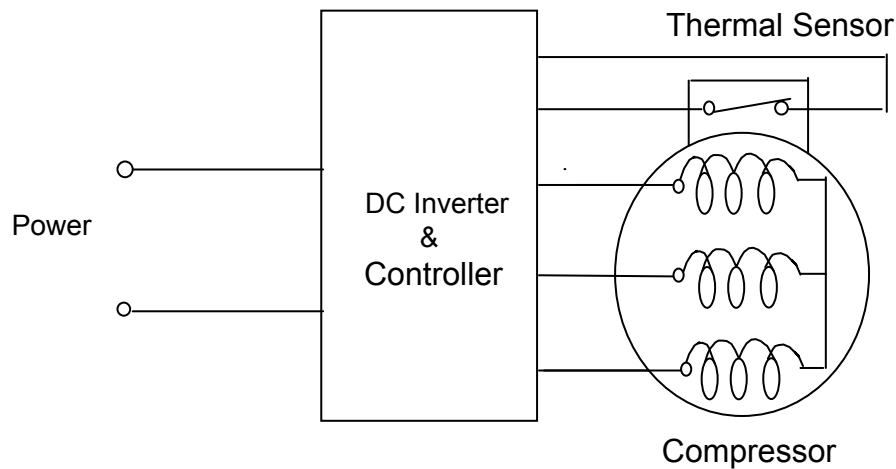

Test in resistance.

TOOL: Multi-meter.

Test the resistance of the winding. The compressor is fault if the resistance of winding 0(short circuit)or ∞ (open circuit).

Familiar error:

- 1) Compressor motor lock.
- 2) Discharge pressure value approaches static pressure value.
- 3) Compressor motor winding abnormality.

Notes:

- 1) Don't put a compressor on its side or turn over.
- 2) Please assembly the compressor in your air conditioner rapidly after removing the plugs.
Don't place the comp. In air for a long time.
- 3) Avoiding compressor running in reverse caused by connecting electrical wire incorrectly.
- 4) Warning! In case AC voltage is impressed to compressor, the compressor performance will below because of its rotor magnetic force decreasing.

Test in resistance.

TOOL: Multimeter.

Test the resistance of the winding. The compressor is fault if the resistance of winding 0 (short circuit)or ∞ (open circuit)

Familiar error:

- 1) Compressor motor lock.

18. CHECKING COMPONENTS

- 2) Discharge pressure value approaches static pressure value .
- 3) Compressor motor winding abnormality.

Notes:

- 1) Don't put a compressor on its side or turn over.
- 2) Please assembly the compressor in your air conditioner rapidly after removing the plugs. Don't place the comp. In air for a long time.
- 3) Avoiding compressor running in reverse caused by connecting electrical wire incorrectly.
- 4) Warning! In case AC voltage is impressed to compressor, the compressor performance will below because of its rotor magnetic force decreasing.

4. INDUCTANCE

Familiar error:

- 1) Sound abnormality
- 2) Insulation resistance disqualification.

5. STEP MOTOR

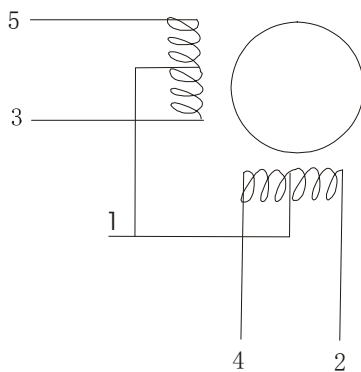

Test in resistance.

TOOL: Multimeter.

Test the resistance of winding. The stepper motor is fault if the resistance of winding 0(short circuit)or ∞ (open circuit) .

6. FUSE

Checking continuity of fuse on PCB ASS'Y.

Remove the PCB ASS'Y from the electrical component box. Then pull out the fuse from the PCB ASS'Y (Fig.1)

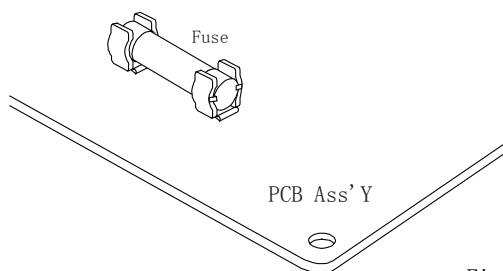

Fig. 1

Check for continuity by a multimeter as shown in Fig.2.

18. CHECKING COMPONENTS

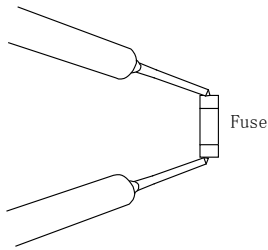

Fig. 2

7. CAPACITOR

Remove the lead wires from the capacitor terminals, and then place a probe on the capacitor terminals as shown in Fig.3.

Observe the deflection of the pointer, setting the resistance measuring range of the multimeter to the maximum value.

* The capacitor is "good" if the pointer bounces to a great extent and then gradually returns to its original position.

* The range of deflection and deflection time differ according to the capacity of the capacitor.

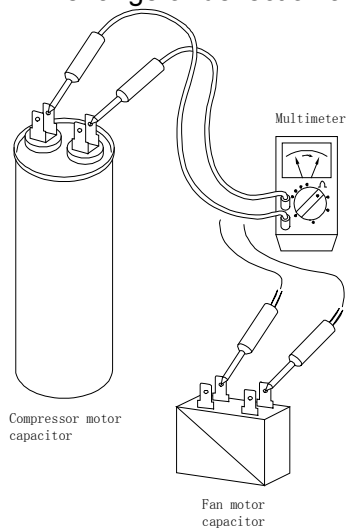
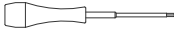
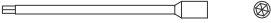

Fig. 3

19. DISASSEMBLY AND ASSEMBLY FOR COMPRESSOR AND MOTOR

19. Disassembly and assembly for compressor and motor

The special tools for compressor & motor disassembly and assembly:

Tool	
1	Hexagon Screwdriver 
2	Hexagon Socket 

Outdoor unit 9K/12K/18K/24K

Important: Before disassembly and assembly, make sure that the power to the system has been disconnected and verified as voltage free.

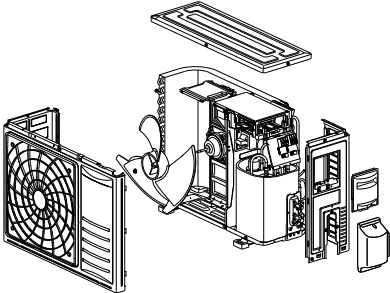
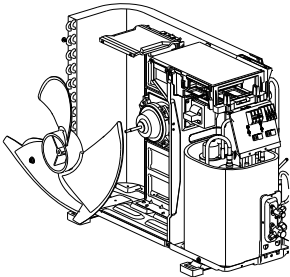
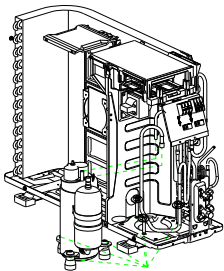
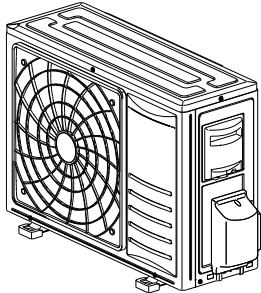
Step	Illustration	Handling Instruction
1. Remove external casing		<ol style="list-style-type: none"> 1. Remove the top cover, handle and valve cover; 2. Remove the outer case and right side plate.
2. Remove motor		<ol style="list-style-type: none"> 1. Remove the blade nut and then remove the blade; 2. Remove the motor from motor supporter
3. Remove compressor		<ol style="list-style-type: none"> 1. Reclaim the refrigerant from the entire system. 2. Unsolder the 4-way valve piping assy from compressor; 3. Remove the compressor mounting bolts; 4. Carefully remove the compressor from chassis.
4. Assemble unit		Assemble the unit in the reverse order of disassembly.

19. DISASSEMBLY AND ASSEMBLY FOR COMPRESSOR AND MOTOR

30K/36K/42K

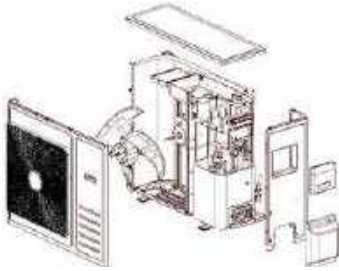
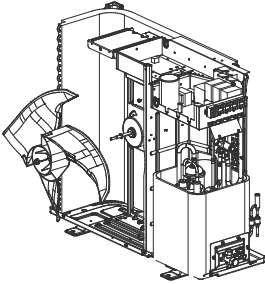
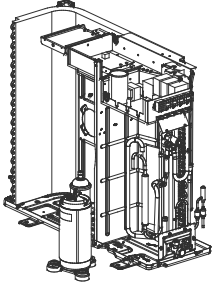
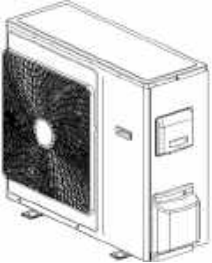

Important: Before disassembly and assembly, make sure that the power to the system has been disconnected and verified as voltage free.

Step	Illustration	Handling Instruction
1.Remove external casing		<ol style="list-style-type: none"> 1. Remove the top cover, handle and valve cover; 2. Remove the outer case and right side plate.
2.Remove motor		<ol style="list-style-type: none"> 1. Remove the blade nut and then remove the blade; 2. Remove the motor from motor supporter
3.Remove compressor		<ol style="list-style-type: none"> 1. Reclaim the refrigerant from the entire system. 2. Unsolder the 4-way valve piping assy from compressor; 3. Remove the compressor mounting bolts; <p>Carefully remove the compressor from chassis.</p>
4.Assemble unit		<p>Assemble the unit in the reverse order of disassembly.</p>

19. DISASSEMBLY AND ASSEMBLY FOR COMPRESSOR AND MOTOR

48K/60K

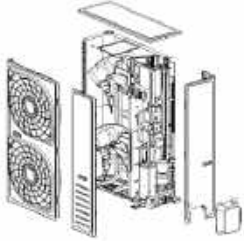
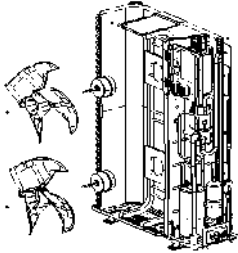
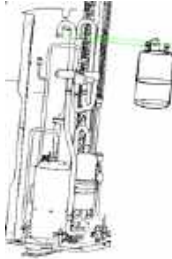
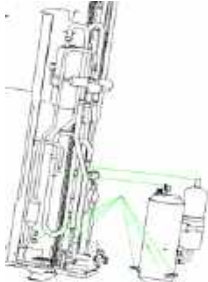
Important: Before disassembly and assembly, make sure that the power to the system has been disconnected and verified as voltage free.

Step	Illustration	Handling Instruction
1. Remove external casing		<ol style="list-style-type: none"> 1. Remove the top cover, handle and valve cover; 2. Remove the outer case and right side plate.
2. Remove motor		<ol style="list-style-type: none"> 1. Remove the blade nut and then remove the blade; 2. Remove the motor from motor supporter.
3. Remove gas liquid separator		<ol style="list-style-type: none"> 1. Reclaim the refrigerant from the entire system. 2. Unsolder the 4-way valve piping assy from gas liquid separator; 3. Remove the gas liquid separator.
4. Remove compressor		<ol style="list-style-type: none"> 1. Reclaim the refrigerant from the entire system. 2. Unsolder the 4-way valve piping assy from compressor; 3. Remove the compressor mounting bolts by using hexagon socket; 4. Carefully remove the compressor from chassis.
5. Assemble unit		<p>Assemble the unit in the reverse order of disassembly.</p>

19. DISASSEMBLY AND ASSEMBLY FOR COMPRESSOR AND MOTOR

Duct type

9K/12K/18K/24K

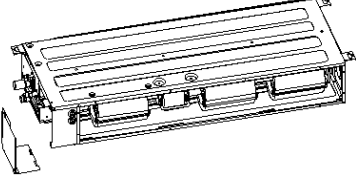
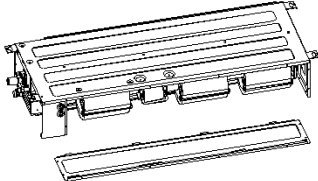
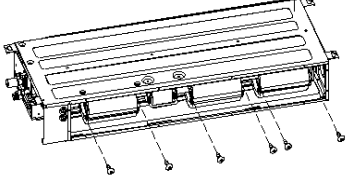
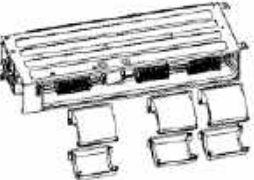
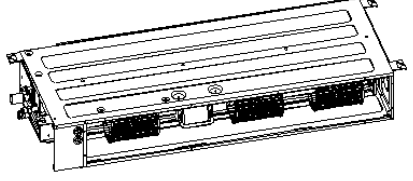
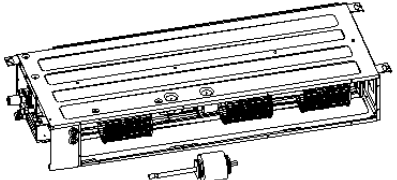
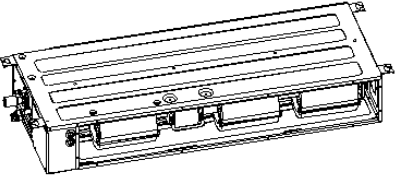
Removal and Assembly of Fan Motor		
Important: Before removing the fan, make sure power to the system is disconnected.		
Step	Illustration	Handling Instruction
1. Unplug the motor cables		Use screwdriver to remove the electric box cover and unplug the motor cables in electric box.
2. Remove the base board		Loose and take out the screws fixing the base board, then remove the base board.
3. Remove the screws on fan sub-assembly.		Remove the screws on fan sub-assembly.
4. Removing the fan cage enclosure		Rotate the fan cage housing toward supply opening and remove.
5. Loosen the fan, crosshead and motor.		Use a hex wrench to loosen the screws holding the fan cage to the motor shaft, and the screws holding the crosshead to the motor shaft. Remove outer housing holding motor in place.
6. Replace the motor		Remove the motor from the support bracket. Then remove the fan cages from the motor shafts. Remove the motor from the air inlet and replace with new motor. Be sure to tighten the cages onto the motor shafts.
7. Reassembly of the unit		Reassemble the unit in the reverse order of disassembly and test operation.

19. DISASSEMBLY AND ASSEMBLY FOR COMPRESSOR AND MOTOR

30K/36K

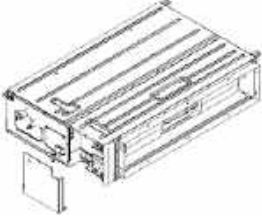
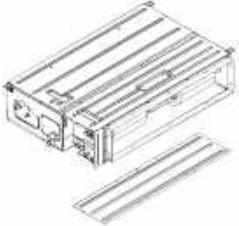
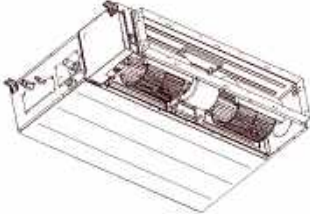
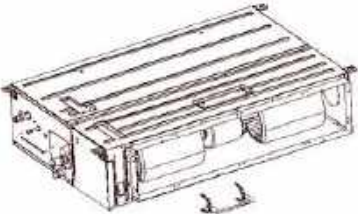
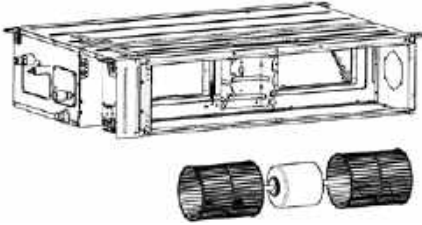
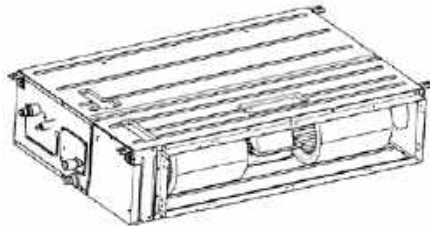
Removal and Assembly of Fan Motor		
Important: Before removing the fan, make sure power to the system is disconnected.		
Step	Illustration	Handling Instruction
1. Unplug the motor cables		Use screwdriver to remove the electric box cover and unplug the motor cables in electric box.
2. Remove the base board		Loose and take out the screws fixing the base board, then remove the base board.
3. Remove the screws on fan sub-assembly and fan cage enclosure.		Remove the screws on fan sub-assembly. Rotate the fan cage housing toward supply opening and remove it.
4. Loosen the hook parts and put the motor with fan sub-assembly on the ground.		Loosen the hook parts. Then put the motor with fan sub-assembly on the ground.
5. Loosen the fan and motor, then replace the motor.		Use a hex wrench to loosen the screws holding the fan cage to the motor shaft. Replace with new motor. Be sure to tighten the cages onto the motor shafts.
7. Reassembly of the unit		Reassemble the unit in the reverse order of disassembly and test operation.

19. DISASSEMBLY AND ASSEMBLY FOR COMPRESSOR AND MOTOR

42K/48K/60K

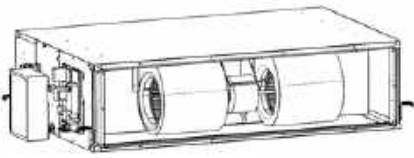
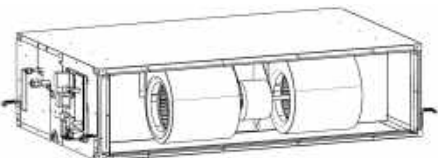
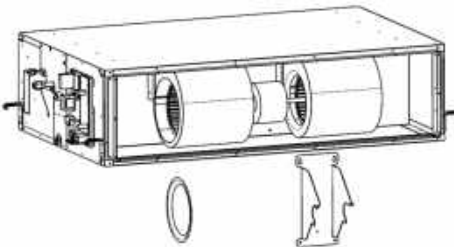
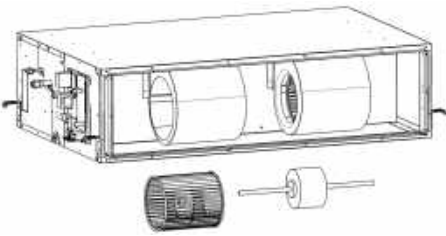
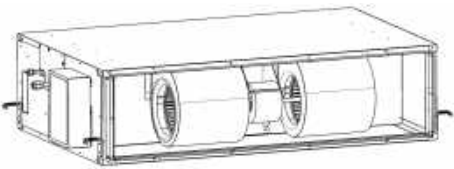
Removal and Assembly of Fan Motor		
Important: Before removing the fan, make sure power to the system is disconnected.		
Step	Illustration	Handling Instruction
1. Unplug the motor cables		Use screwdriver to remove the electric box cover and unplug the motor cables in electric box.
2. Loosen the fan and motor.		Use a offset spanner to loosen the screws holding the fan cage to the motor shaft. Remove outer housing holding motor in place.
3. Remove the diversion circle and support bracket.		Use screwdriver to remove the diversion circle and support bracket.
4. Replace the motor		Remove the fan cage from the motor shaft. Remove the motor from the air inlet and replace with new motor. Be sure to tighten the cages onto the motor shafts.
5. Reassembly of the unit		Reassemble the unit in the reverse order of disassembly and test operation.

19. DISASSEMBLY AND ASSEMBLY FOR COMPRESSOR AND MOTOR



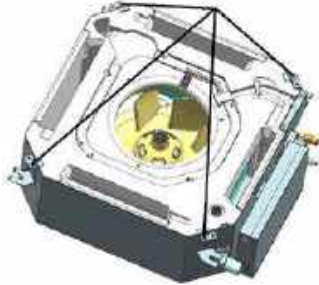
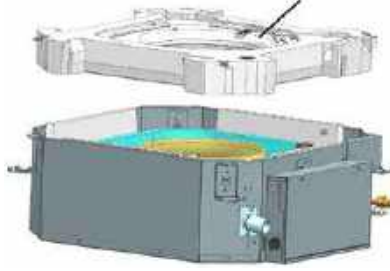
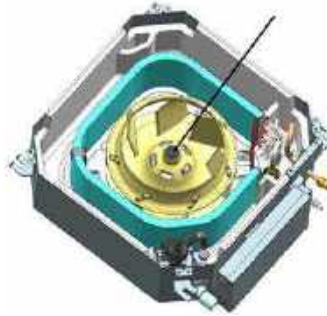
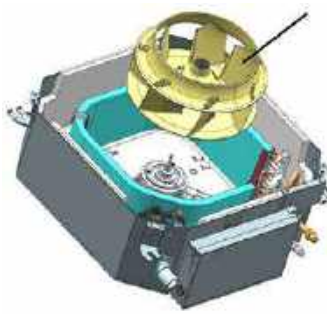
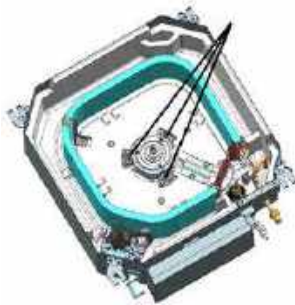

Cassette type
9K~18K

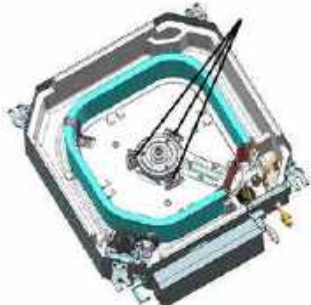
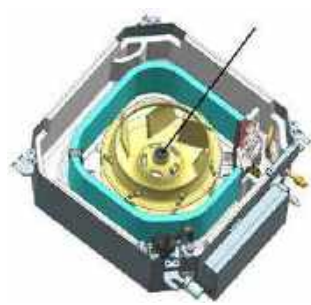
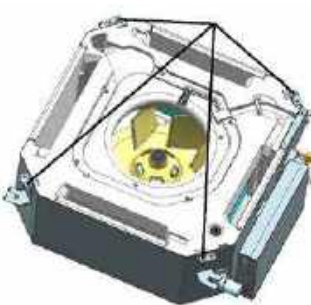
Replacement of Fan Motor		
Step	Illustration	Handling Instruction
1. Loosen the screws holding condensate pan.		Use screwdriver to loosen the screws holding the drain pan in place.
2. Remove the condensate pan		Carefully remove the condensate pan.
3. Loosen the bolt holding the fan blade in place		Use a wrench or socket to carefully remove the fan blade bolt.
4. Remove the fan blade		The fan blade can now be removed.
5. Loosen the bolts holding the motor in place		Use a wrench or socket to carefully remove the motor bolts.

19. DISASSEMBLY AND ASSEMBLY FOR COMPRESSOR AND MOTOR

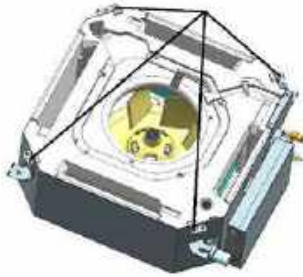
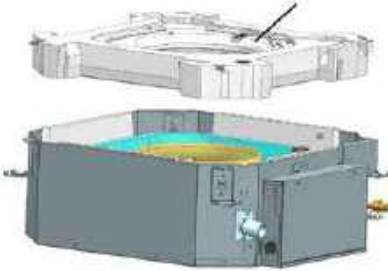
Replacement of Fan Motor		
Step	Illustration	Handling Instruction
6. Remove the motor and replace it		Remove the motor and replace it.
7. Tighten the bolts holding the motor		Use a wrench or socket to carefully tighten the motor bolts.
8. Mount the fan blade and tighten the bolt		Mount the fan blade and use a wrench or socket to carefully tighten the bolt holding the fan blade in place. Do not overtighten as damage may occur.
9. Reinstall the condensate pan and tighten the screws		Use a screwdriver to carefully tighten the screws holding the condensate pan in place. Take care to not overtighten as damage to pan will occur.

19. DISASSEMBLY AND ASSEMBLY FOR COMPRESSOR AND MOTOR

Removal and Installation of Condensate Pump		
Step	Illustration	Handling Instruction
1. Loosen the screws holding condensate pan		Use screwdriver to loosen the screws holding the drain pan in place.
2. Remove the condensate pan		Carefully remove the condensate pan.
3. Pull out the water outlet pipe		Pull out the water outlet Pipe.
4. Loosen the screws holding the condensate pump.		Loosen the screws holding the condensate pump.
5. Take out the pump and replace it		Take out the pump and replace it.

19. DISASSEMBLY AND ASSEMBLY FOR COMPRESSOR AND MOTOR

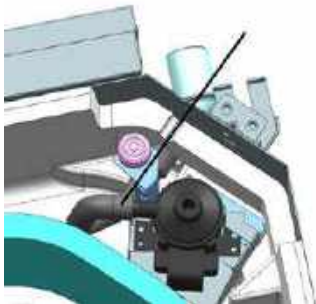
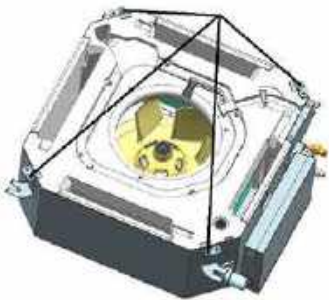
Removal and Installation of Condensate Pump		
Step	Illustration	Handling Instruction
6. Tighten the screws holding the condensate pump		Use a screwdriver to tighten the screws holding the condensate pump in place.
7. Connect the condensate pipe		Connect the condensate pipe
8. Mount the condensate pan and tighten the screws		Use a screwdriver to carefully tighten the screws holding the condensate pan in place. Damage may occur if over tightened.

19. DISASSEMBLY AND ASSEMBLY FOR COMPRESSOR AND MOTOR

Cassette type
24K~60K

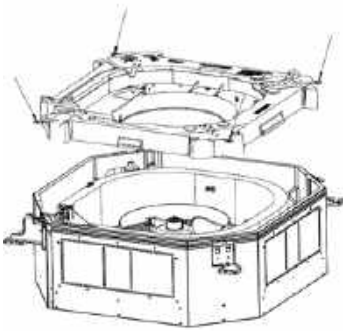
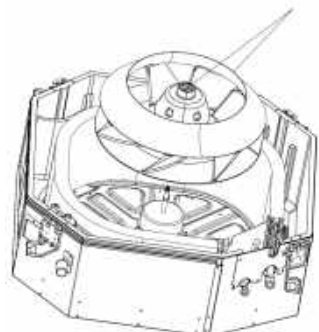
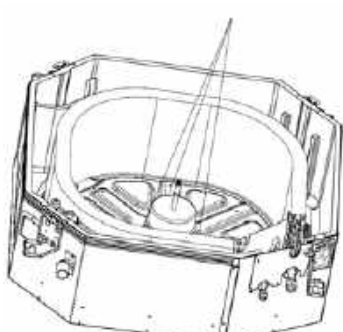
Step	Illustration	Handling Instruction
<p>1. Loosen the screws holding the electric box cover and electric box.</p>		<p>Use screwdriver to loosen the Electric box.</p>
<p>2. Loosen the screws holding condensate pan and Remove the condensate pan.</p>		<p>Use screwdriver to loosen the screws holding the drain pan in place.</p>
<p>3. Loosen the bolts holding the fan blades in place and Remove the fan blade.</p>		<p>Use a wrench or socket to carefully remove the fan blade bolts.</p>
<p>4. Loosen the screws holding the motor in place and Remove the motor and replace it.</p>		<p>Use screwdriver to loosen the screws holding the motor.</p>

19. DISASSEMBLY AND ASSEMBLY FOR COMPRESSOR AND MOTOR

Ceiling & Floor type

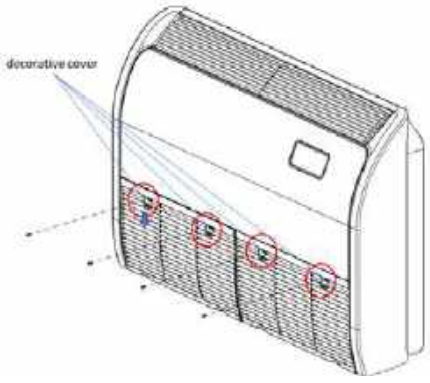
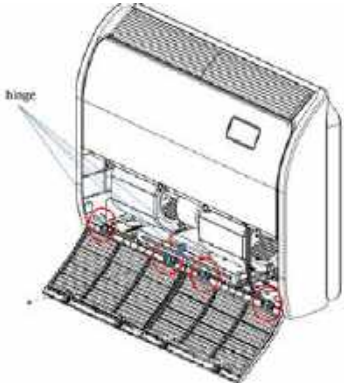
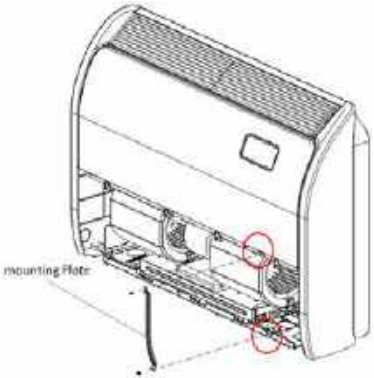
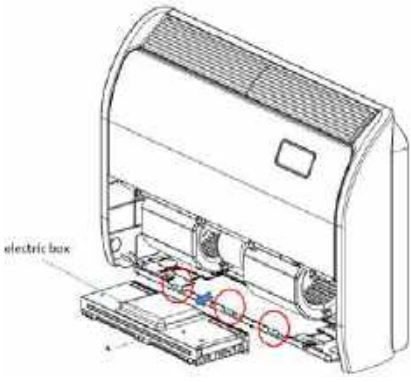
Removal of the motor		
Step	Illustration	Handling Instruction
1. Disassembly of the down front panel assembly		Slide open the 4 decorative covers, loose and take out the 4 screws, then open the down front panel assembly.
		Loose and take out the 4 screws fixing the hinge, then remove the down front panel assembly.
2. Disassembly of the mounting Plate		Loose and take out the 2 screws fixing the mounting Plate, then remove it.
3. Disassembly of the electric box		Loose and take out the 3 screws fixing the electric box, then take it.

19. DISASSEMBLY AND ASSEMBLY FOR COMPRESSOR AND MOTOR

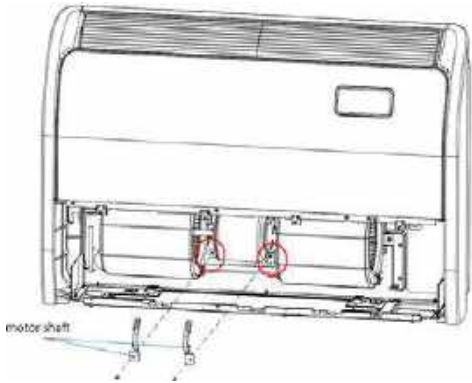
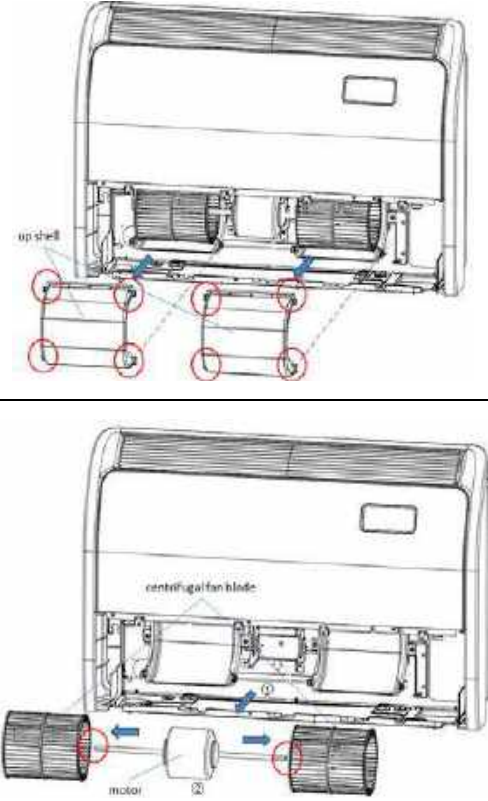
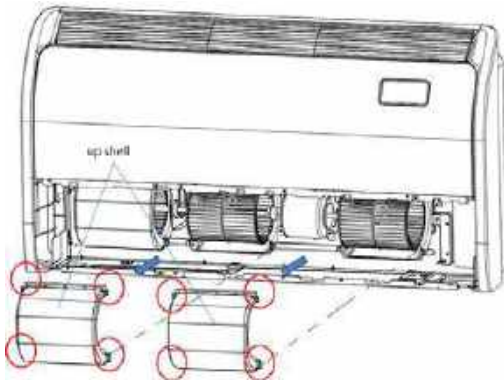
Removal of the motor		
Step	Illustration	Handling Instruction
4. Disassembly of the motor shaft		Remove the 2 screws fixing the motor shaft and fan blade by allen screwdriver.
5. Disassembly of the motor (18K/24K)		Remove the fasteners between the up shell and the below shell; Take out of the motor and centrifugal fan blade; Remove the 2 screws fixing the centrifugal fan blade and get the motor.
5. Disassembly of the motor (30K/36K)		Remove the fasteners between the up shell and the below shell on both sides of the motor; Remove the 2 screws fixing the Crosshead and take it away from the motor; Take out of the motor and centrifugal fan blade; Remove the 2 screws fixing the centrifugal fan blade and get the motor.

19. DISASSEMBLY AND ASSEMBLY FOR COMPRESSOR AND MOTOR

Removal of the motor		
Step	Illustration	Handling Instruction
5. Disassembly of the motor (42K~60K)		<p>Remove the fasteners between the up shell and the below shell on both sides of the motor;</p> <p>Remove the 2 screws fixing the Crosshead and take it away from the motor;</p> <p>Take out of the motor.</p>

19. DISASSEMBLY AND ASSEMBLY FOR COMPRESSOR AND MOTOR

Console type

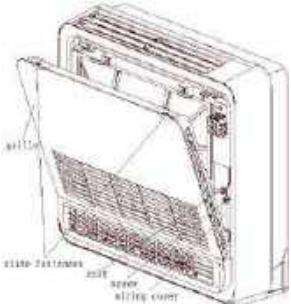
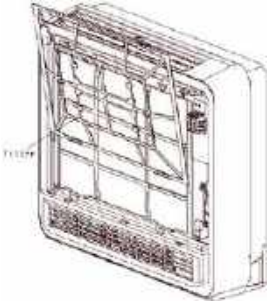
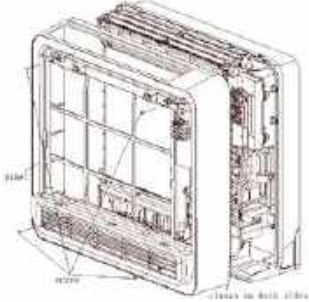
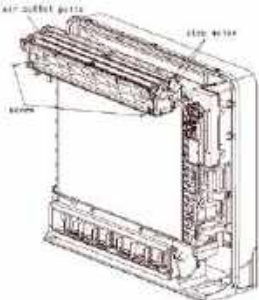
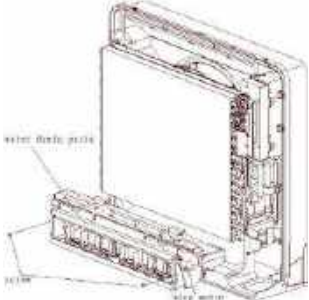
Removal of the motor		
Step	Illustration	Handling Instruction
1. Remove grille		<p>Push the slide fasteners on the upper side of grille to open side; Pull the grille outwards, take off the coil, and lift up the grille; Remove the screw fixing wiring cover, pull out the plug of display wire and then remove the grille.</p>
2. Remove filter		<p>Loosen the clasp on the upper side of filter, pull the filter upwards to remove it.</p>
3. Remove panel		<p>Remove the 4 screws fixing panel; Disengage the clasps on both sides (Follow the arrows); Pull the panel upwards, and then remove it.</p>
4. Remove air outlet parts		<p>Remove the 2 screws fixing air outlet parts, pull out the connection wires between step motor and electric box, and then pull the air outlet parts outwards to remove it.</p>
5. Remove water drain parts		<p>Remove the 2 screws fixing water drain parts, pull out the connection wires between step motor and electric box, and then pull the water drain parts outwards to remove it.</p>

19. DISASSEMBLY AND ASSEMBLY FOR COMPRESSOR AND MOTOR

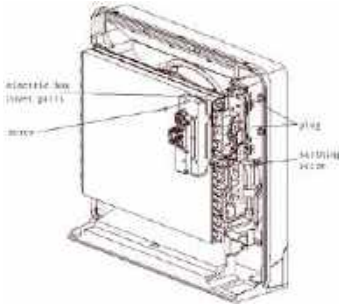
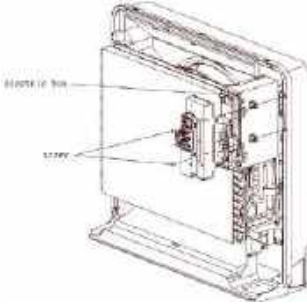
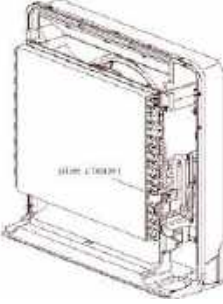
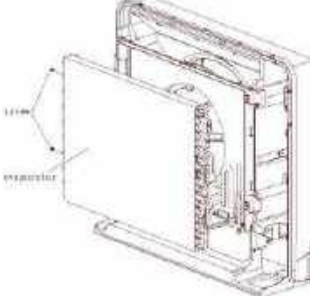
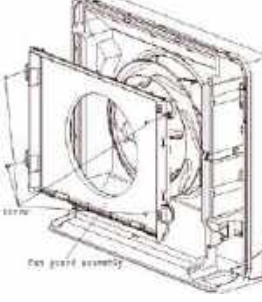
Removal of the motor		
Step	Illustration	Handling Instruction
6. Remove electric box cover parts		Remove the screw fixing electric box cover parts, remove the earth screw on the evaporator, pull out plugs of temperature sensor and DC motor wire, and then pull the electric box cover parts outwards to remove it.
7. Remove electric box		Remove the 2 screws fixing electric box, pull out all connection wires, and then pull the electric box outwards to remove it.
8. Remove pipe clamber		Loosen the clasp between pipe clamber and base, and then pull the pipe clamber outwards to remove it.
9. Remove evaporator		Remove the 2 screws fixing evaporator, loosen the clasps between the evaporator and base, and then pull the evaporator outwards to remove it.
10. Remove fan guard assembly		Remove the 4 screws fixing fan guard assembly, and then remove it.

19. DISASSEMBLY AND ASSEMBLY FOR COMPRESSOR AND MOTOR

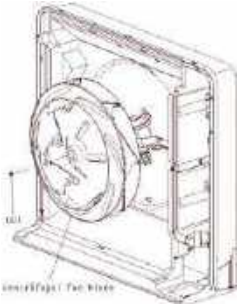
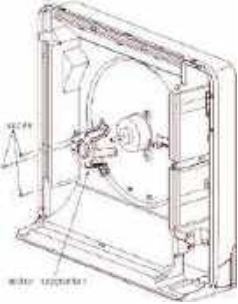
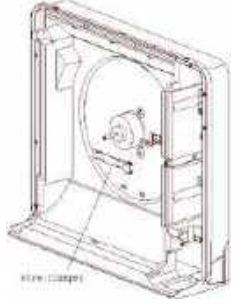
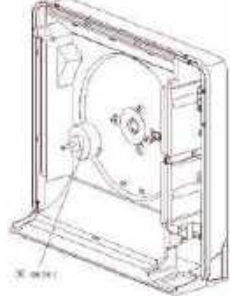
Removal of the motor		
Step	Illustration	Handling Instruction
11. Remove centrifugal fan blade		Remove nut on centrifugal fan blade, and then pull the centrifugal fan blade outwards to remove it.
12. Remove motor supporter		Remove the 3 screws fixing motor supporter, and then remove it.
13. Remove wire clasper		Loosen clasps between wire clasper and base, and then remove it.
14. Remove DC motor		Remove DC motor.

20. CONTORL LOGIC DESCRIPTION

20. Control logic description

20.1 Fan Only Mode

- (1) Outdoor fan and compressor stop.
- (2) Temperature setting function is disabled, and no setting temperature is displayed.
- (3) Indoor fan can be set to high/medium/low, but can not be set to auto.

20.2 Cooling Mode

Indoor fan running rules:

In cooling mode, indoor fan runs all the time and the speed can be selected as high,(medium), low and auto.

The auto fan:

T1 is indoor room temperature. Ts is setting temperature.

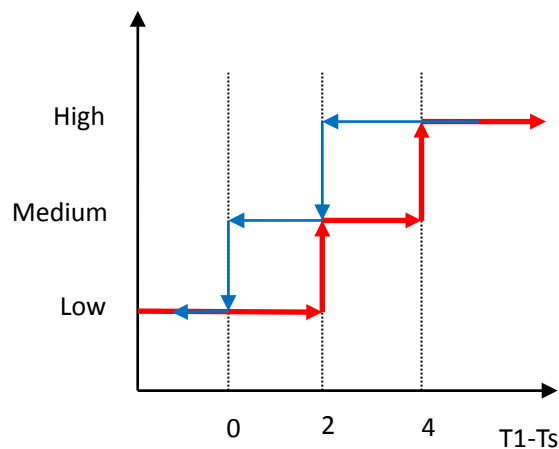

Inverter outdoor unit:

Compressor and outdoor fan running rules:

Once the compressor starts up, it will follow the below rules:

When indoor room temp. T1 is lower than Ts, the compressor and outdoor fan will shut off. When T1 is higher than Ts+1, the compressor and outdoor fan will start up.

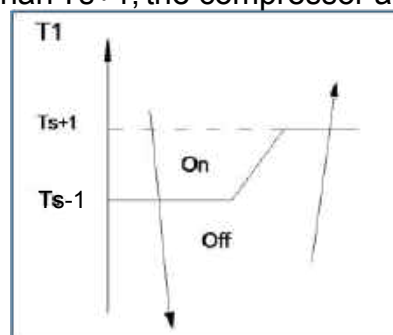

Outdoor fan running rules:

Once the outdoor fan start up, it will follow the below rules:

Single outdoor fan: First, it will run in an invariable speed for a short time; Then it will regulate the speed by the outdoor-coil temperature.

Double outdoor fan: If it has two outdoor fans, the upper fan regulates the speed by the rules, and the downer fan speed lower than the upper fan speed for 30rpm~60rpm.

20. CONTORL LOGIC DESCRIPTION

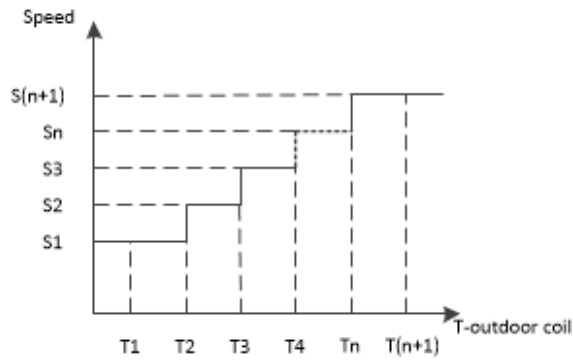

20.3 Heating Mode

Indoor fan running rules:

In several minutes after the heating mode is started, the fan of the indoor unit will not run until the heat exchanger of the indoor unit reaches a high enough temperature. That is because cold air prevention system is operating. After several minutes, the speed can be selected as high, (medium), low and auto.

The auto fan:

T_1 is indoor room temperature. T_s is setting temperature.

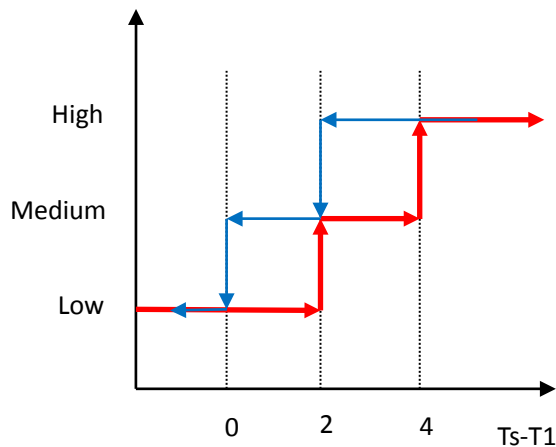

DC-Inverter outdoor unit:

Outdoor fan running rules:

Once the outdoor fan start up, it will follow the below rules:

Single outdoor fan: First, it will run in an invariable speed for a short time; Then it will regulate the speed by the indoor-coil temperature.

Double outdoor fan: If it has two outdoor fans, the upper fan regulates the speed by the rules, and the downer fan speed lower than the upper fan speed for 30rpm~60rpm.

20. CONTORL LOGIC DESCRIPTION

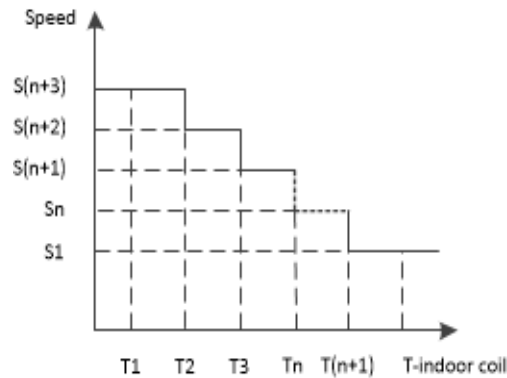

20.4 Auto Mode

This mode can be chosen with remote controller and the setting temperature can be changed between 16~30°C.

In auto mode, the machine will choose cooling, heating or fan-only mode according to ΔT ($\Delta T = T1 - Ts$).

$\Delta T = T1 - Ts$	Running mode
$\Delta T > 3^{\circ}\text{C}$	Cooling
$-3^{\circ}\text{C} \leq \Delta T \leq 3^{\circ}\text{C}$	Fan-only
$\Delta T < -3^{\circ}\text{C}$	Heating

Indoor fan will run at auto fan of the relevant mode. The louver operates same as in relevant mode. If the compressor keep stopping for 10 minutes or the setting temperature is modified, the machine will choose mode according to ΔT again.

20.5 Evaporator Low-temperature Protection

DC-Inverter

AC will enter T2 protection if any of the following condition is satisfied.

Condition:

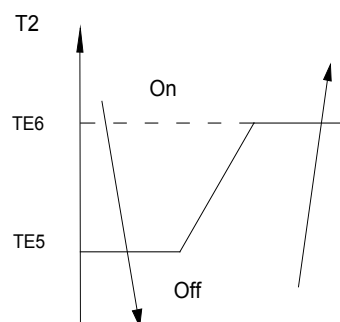

Cooling mode: When the indoor coil temp. T2 keeps lower than TE5 for 120 seconds, the compressor and outdoor fan will shut off. When T2 is higher than TE6, the compressor and outdoor fan will restart up.

20. CONTORL LOGIC DESCRIPTION

20.6 Condenser High-temperature Protection

DC-Inverter outdoor unit

AC will enter T3 protection if any of the following conditions is satisfied.

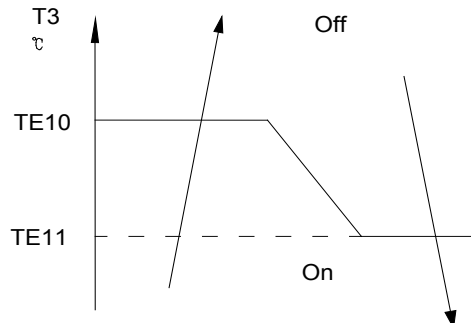

Condition1:

Cooling mode: When the outdoor coil temp. T3 keeps higher than T2 for 10 seconds, the compressor and outdoor fan will shut off. When T3 is lower than T1, the compressor and outdoor fan will restart up.

Condition2:

Heating mode: When the indoor coil temp. T3 keeps higher than T2 for 10 seconds, the compressor and outdoor fan will shut off. When T3 is lower than T1, the compressor and outdoor fan will restart up.

Hisense

Product improvement, specifications and appearance in this manual are subject to change without prior notice.