



CONTENTS

| | |
|---|----|
| PRECAUTION | 1 |
| PARTS AND FUNCTIONS | 3 |
| REMOTE CONTROLLER OPERATION | 4 |
| TROUBLES AND CAUSES | 10 |
| IMPORTANT SAFETY INFORMATION | 11 |
| INDOOR UNIT INSTALLATION | 12 |
| Figure of body size | 17 |
| OUTDOOR UNIT INSTALLATION | 18 |
| REFRIGERANT PIPE INSTALLATION | 20 |
| ELECTRIC WIRING | 22 |
| TRY TEST | 24 |
| TROUBLESHOOTING | 25 |
| TROUBLE DISPLAY OF INTDOOR/OUTDOOR | 26 |

PRECAUTION

- Read the following " PRECAUTIONS" carefully before installation.
- The caution items stated here must be followed because these important contents are related to safety. The meaning of each indication used is as below.
Incorrect installation due to ignoring of the instruction will cause harm or damage, and the seriousness is classified by the following indications.

| | |
|---|---|
|  WARNING | This indication shows the possibility of causing death or serious injury. |
|  CAUTION | This indication shows the possibility of causing injury or damage to properties only. |

NOTE :

1. Injury means causing harmed, burned, electrical shocked, but not serious for hospitalization.
 2. Damage of property means disrepair of property, material.
- Carry out test running to confirm that no abnormality occurs after the installation. Then, explain to user the operation, care and maintenance as stated in instructions. Please remind the customer to keep the operating instructions for future reference.

|  WARNING |
|--|
| ● Engage dealer or specialist for installation. If installation done by user is defective, it will cause water leakage, electrical shock or fire. |
| ● Install according to this installation instructions strictly. If installation is defective, it will cause water leakage, electrical shock or fire. |
| ● Use the attached accessories parts and specified parts for installation. Otherwise, it will cause the set to fall, water leakage, fire or electrical shock. |
| ● Install at a strong and firm location which is able to withstand the set's weight. If the strength is not enough or installation is not properly done, the set will drop and cause injury. |
| ● For electrical work, follow the local national wiring standard, regulation and this installation instructions. An independent circuit and single outlet must be used. If electrical circuit capacity is not enough or defect found in electrical work, it will cause electrical shock or fire. |
| ● When carrying out piping connection, take care not to let air or other substances other than the specified refrigerant go into refrigeration cycle. Otherwise, it will cause lower capacity, abnormal high pressure in the refrigeration cycle, explosion and injury. |
| ● Grounding is necessary. It may cause electrical shock if grounding is not perfect. |
| ● Do not install the unit at place where leakage of flammable gas may occur. In case gas leaks and accumulates at surrounding of the unit, it may cause fire. |

Operating condition

The protective device may trip and stop the unit within temp range listed below:

| | |
|----------------|---------------------------------------|
| HEATING | Outdoor air temperature is over 21°C |
| | Outdoor air temperature is below -7°C |
| | Room temperature is over 31°C |
| COOLING | Outdoor air temperature is over 43°C |
| | Room temperature is below 17°C |
| DRY | Room temperature is below 18°C |

If the air conditioner runs for a long time in "COOLING" or "DRY" mode at air relative humidity higher than 80% (doors or windows opened), dew may generate and drip near air outlet.

Noise pollution

- Install the air conditioner in a place that can bear its weight in order to operate more quietly.
- Install the outdoor unit in a place where the air discharged and the operation noise do not annoy your neighbors.
- Do not place any obstacles in front of the outlet of the outdoor unit for fear it affects operation and increases the noise level.

Features of Protector

- 1 The protective device will trip at following cases.
 - Stop the appliance and restart it at once or change other modes during operation, you have to wait 3 minutes before restarting.
 - After switching on the power circuit breaker and then turn on the air conditioner at once, you have to wait about 20 seconds.
- 2 In case all operations have stopped, you need
 - Press "ON/OFF" button again to restart it.
 - Set TIMER once again if it has been canceled.

Inspection

After a long time of operation, the air conditioner should be inspected for the following items.

- Abnormal heating of the power supply cord and plug or even a burnt smell.
- Abnormal operating noise or vibration.
- Water leakage from indoor unit.
- Metal cabinet electrified .
- ✎ Stop using the air conditioner if above problem happened.
It is advisable that the air conditioner should be given a detail check-up after using for five years even if none of the above happen.

Feature of HEATING mode

Preheat

2-5 minutes are necessary to preheat the indoor heat exchanger at the beginning of "HEATING" operation, lest cold air be discharged.

Defrost

In "HEATING" operation the appliance will defrost automatically. This procedure lasts 2~10 minutes, then returns to "HEATING" mode automatically. During defrosting, indoor fan stop running and return to heating mode operation automatically when defrosting has finished.

PARTS AND FUNCTIONS

Indoor Unit

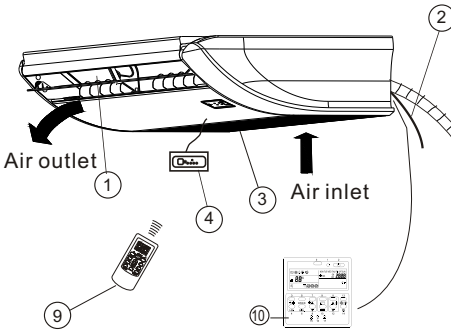

- ① Air Outlet
- ② Refrigerant Pipe Junction
- ③ Filter
- ④ Remote controller receiver
- ⑤ Refrigerant connection pipe
- ⑥ Connecting cord
- ⑦ Stop valve
- ⑧ Air Outlet grille
- ⑨ Remote controller
- ⑩ Classical wall controller

Outdoor Unit

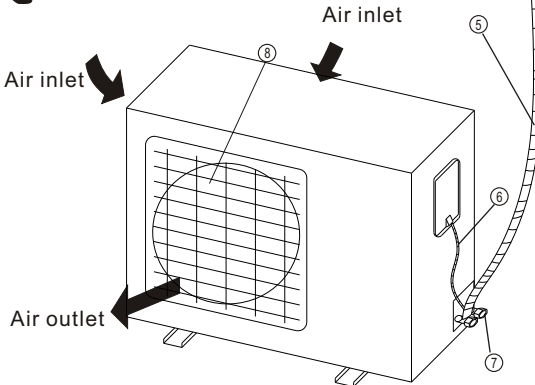

Requirements

- The air conditioner cannot be started up until it is powered on for 2 hours. Furthermore, in case of a shutdown lasting for about one diel only, please do not cut off the electricity supply. (it is necessary to heat the crankcase heater so as to avoid force start of compressor.)
- Notice that the air inlet/outlet must not be choked up. If chokeup takes place, the air conditioner behavior may be affected, or air conditioner cannot run because of actuation of protector.

REMOTE CONTROLLER

| No. | Button | Function |
|-----|-------------|--|
| 1 | ▲ (TEMP UP) | Increase the temperature or time by 1 unit |
| 2 | ▼ (TEMP DN) | Decrease the temperature or time by 1 unit |
| 3 | ON/OFF | To switch the conditioner on and off. |
| 4 | ECO | In cooling mode, press this button, the temperature will increase 2°C on the base of setting temperature In heating mode, press this button, the temperature will decrease 2°C on the base of setting temperature |
| 5 | MODE | To select the mode of operation |
| 6 | SLEEP | To activate the function "SLEEP" |
| 7 | FAN | To select the fan speed of auto/low/mid/high |
| 8 | SWING | To activate or deactivate of the movement of the "DEFLECTORS" |
| 9 | HEALTHY | To switch - on/off HEALTHY function. It is a button which controls the ionizer or plasma generator only for inverter type. |
| 10 | TURBO | In cooling mode, press this button, the unit will give the maximum cooling temperature with 16°C In heating mode, press this button, the unit will give the maximum heating temperature with 31°C |
| 11 | DISPLAY | To switch on/off the LED display (if present) |
| 12 | TIMER | To set automatic switching-on/off |

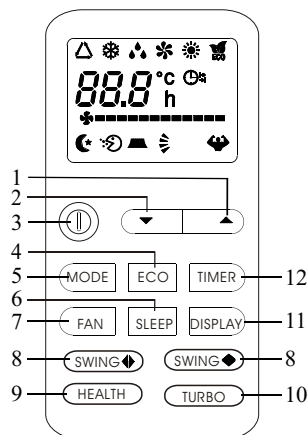

△ The outlook and some function of remote control may vary according to the model.

△ The shape and position of buttons and indicators may vary according to the model, but their function is the same.

The unit confirms the correct reception of each press button with a beep.

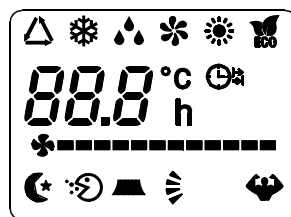

Remote control DISPLAY

Meaning of symbols on the liquid crystal display

| No. | Symbols | Meaning | No. | Symbols | Meaning |
|-----|---------|------------------------------|-----|---------|----------------------------|
| 1 | △ | FEEL mode indicator | 10 | ⋄----- | MIDDLE FAN SPEED indicator |
| 2 | ❄ | COOLING indicator | 11 | ⋄----- | HIGH FAN SPEED indicator |
| 3 | 💧 | DEHUMIDIFYING indicator | 12 | ☾ | SLEEP indicator |
| 4 | 🌀 | FAN ONLY OPERATION indicator | 13 | ⚡ | SUPER indicator |
| 5 | ☀ | HEATING indicator | 14 | 🕒 | HEALTHY indicator |
| 6 | 🕒 | TIMER OFF indicator | 15 | 🌿 | ECO indicator |
| 7 | 🕒 | TIMER ON indicator | 16 | 🔋 | BATTERY indicator |
| 8 | ⋄- | AUTO FAN indicator | 17 | 🔋 | BATTERY indicator |
| 9 | ⋄---- | LOW FAN SPEED indicator | 18 | 🕒 | CLOCK indicator |

COOLING MODE

The cooling function allows the air conditioner to cool the room and at the same time reduces the humidity in the air.

To activate the cooling function (COOL) , press the MODE button until the symbol ❄️ appears on the display.

The cooling cycle is activated by setting the keys ▲ or ▼ at a temperature lower than that of the room.

To optimize the functioning of the conditioner, adjust the temperature (1), the speed (2) and the direction of the air flow (3) by pressing the keys indicated

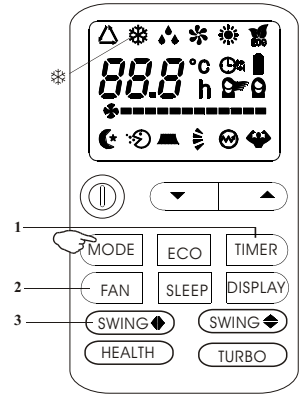

HEATING MODE

The heating function allows the air conditioner to produce hot air.

To activate the heating function (HEAT) , press the

MODE button until the symbol ☀️ appears on the display.

With the keys ▲ or ▼ set a temperature higher than that of the room..

To optimize the functioning of the conditioner adjust the temperature (1), the speed (2) and the direction of the air flow (3) by pressing the keys indicated

⚠️ The appliance is fitted with a Hot Start function, which delays appliance to startup in a few seconds to ensure an immediate output of hot air.

⚠️ In HEATING operation, the appliance can automatically activate a defrost cycle, which is essential to free the condenser from an excessive deposit of frost .This procedure usually lasts for 2-10 minutes during defrosting,fans stop operation. After defrosting ,it returns to HEATING mode automatically.

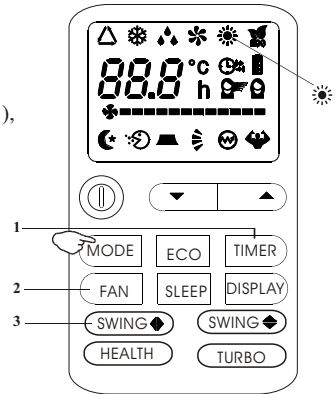

FAN MODE

The conditioner works in only ventilation.

To set the FAN mode , Press MODE until ❄️ appears in the display.

With pressing FAN button the speed changes in the following sequence: LOW/ MEDIUM/HIGH /AUTO in FAN mode.

The remote control also stores the speed that was set in the previous mode of operation.

In FEEL mode (automatic) the air conditioner automatically chooses the fan speed and the mode of operation (COOLING or HEATING).

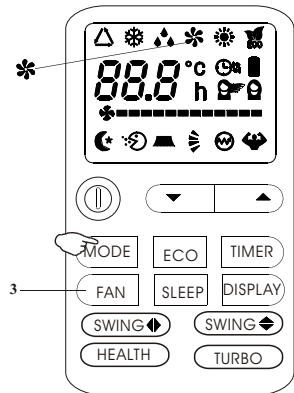

TIMER MODE---TIMER ON

To set the automatic switching on of the air conditioner.

To program the time start,the appliance should be off.

Press **TIMER** ,Set the temperature with pressing the key **▲** or **▼**.,Press **TIMER** Again , set the time with pressing the key **▲** or **▼** , Press the key more times till on the display you can read the time which passes between the programming and the timed start.

IMPORTANT!

Before proceeding with the timed start : program the working mode with the key **MODE**(2) and the fan speed with the key **FAN**(3) . Switch the conditioner off (with the key **ON/OFF**) .

Note:To cancel the setted function ,press the **TIMER** button again.

Note:In case of power off,it is necessary to set **TIMER ON** again.

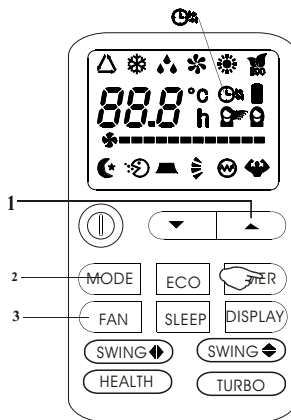

TIMER MODE---TIMER OFF

To set the automatic switching-off of the air conditioner.

The timed stop is programmed with the appliance on.

Press **TIMER** ,Set the time pressing the key **▲** or **▼** , Press the key more times till on the display you can read the time which passes between the programming and the timed stop.

Note:To cancel the setted function, press the **TIMER** button again.

Note:In case of power off,it is necessary to set **TIMER OFF** again.

Note: While the time was right settled, the **TIMER** function of this remote(clock function) can be set by half hours.

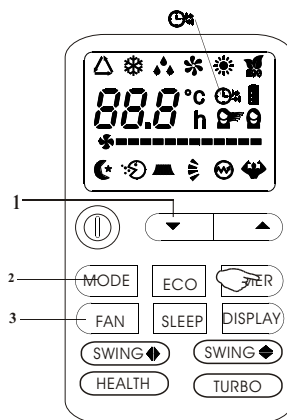

DRY MODE

This function reduces the humidity of the air to make the room more comfortable.

To set the **DRY** mode ,Press **MODE** until **☁** appears in the display . An automatic function of alternating cooling cycles and air fan is activated.

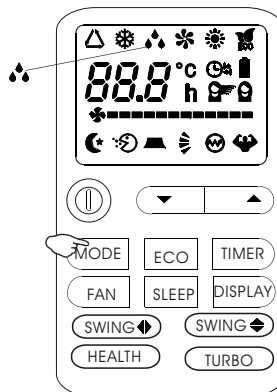

FEEL MODE

To activate the FEEL (automatic) mode of operation, press the MODE button on the remote control until the symbol Δ appears in the display. In the FEEL mode the fan speed and the temperature are set automatically according to the room temperature (tested by the probe which is incorporated in the indoor unit) to ensure user comfort.

| Ambient temp | Operation mode | Auto temp. |
|--------------|---|------------|
| < 20°C | HEATING (FOR HEAT PUMP TYPE) FAN (FOR COOL ONLY TYPE) | 23°C |
| 20°C~26°C | DRY | 18°C |
| > 26°C | COOL | 23°C |

To optimize the working of the conditioner, adjust the temperature (only $\pm 2^\circ\text{C}$) (1), the speed (2) and the direction of the air flow (3) by pressing the buttons indicated.

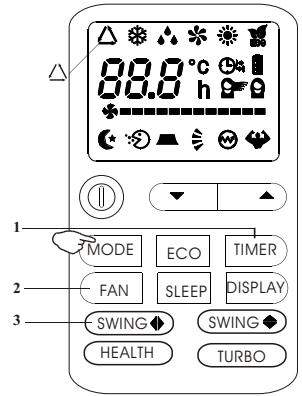

SLEEP MODE

To activate the SLEEP mode of operation, press the SLEEP button on the remote control until the symbol (AUTOQUIET) appears in the display. The function "SLEEP" automatically adjusts the temperature to make the room more comfortable during the night sleep. In cooling or dry mode, the set temperature will automatically raise by 1°C every 60 minutes, to achieve a total rise of 2°C during the first 2 hours of work. In heating mode the set temperature is gradually decreased by 2°C during the first 2 hours of work. After 10 hours running in sleep mode the air conditioner is switched off automatically.

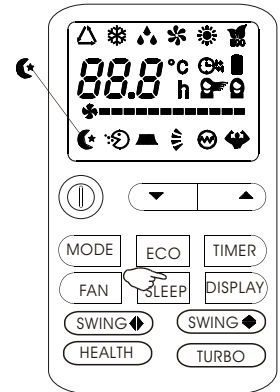

■ Remote controller handling procedure

Batteries replacing procedure

Following cases signify dead cells. Replace the dead batteries with new ones.

- Receiving sound is not emitted from the unit when signal is transmitted.
- Indicator becomes indistinct.

| | |
|----------|------------------------------------|
| 1 | Please slide and remove the cover. |
| | |
| 2 | Exchange the batteries. |
| | |
| 3 | Install the cover. |
| 4 | Set it to the present time. |

NOTE

- Do not use an old battery together with a new one.
- Remove cells when the remote controller is not used for a long period.
- The life of a cell made in conformity to JIS or IEC is 6 to 12 months in normal use. If it is used longer or an unspecified cell is used, a liquid leaks from the cell, causing the remote controller inoperative.

- Guideline of the life time is printed on the battery. The battery life may be shorter than that of the air conditioner depending on the date of manufacture.
- However, the battery may be alive even after the nominal life time expired.

Note of remote controller handling

| | | |
|---|--|--|
| <ul style="list-style-type: none"> • A place with high temperature such as near an electric carpet or a stove. | <ul style="list-style-type: none"> • A place unprotected from direct sunlight or strong lighting. | <ul style="list-style-type: none"> • It will be damaged if fallen. Be careful. |
| <ul style="list-style-type: none"> • Do not put obstacles between the remote controller and the unit. | <ul style="list-style-type: none"> • Protect the remote controller from being splashed with water, etc. | <ul style="list-style-type: none"> • Do not put weights on the remote controller. |

■ Air flow direction adjustment procedure

Adjusting air flow direction

- Up/down direction can be adjusted by using the AIRFLOW button on the remote controller. This button, each time pressed, changes the mode in the following sequence:

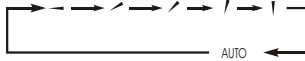

- push the LOUVER button, changes the mode to swing louver. Push the button, to stop swing.

NOTE

- When the room temperature controller (thermostat) trips in the heating mode or when the defrosting operation is conducted, the blow flap changes automatically to the horizontal position.
- When the heating operation has just started and the room temperature is still low, it may take a little time before the flap moves to the above sway operation angle.
- The flap may stop at the tilted down-blow position during the "Sway operation" in the heating mode.

■ About TIMER operation

About Amenity reservation

Amenity reservation function is provided to start the operation a little earlier so that the room temperature is near the optimum temperature at the timer ON time in case of starting the operation by TIMER ON/OFF.

- Mechanism
 - Checking of the room temperature starts 60 minutes ahead of the timer ON time. Depending on the temperature at that time, operation starts 5 to 60 minutes ahead of the timer ON time.
 - Amenity reservation is the function only for COOL and HEAT operation mode (including AUTO). It does not actuate in DRY mode.

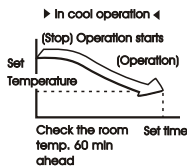

About SLEEP Operation

When the SLEEP operation is selected, the room temperature is automatically controlled with elapsed time so that the room isn't too cool during cooling or too warm during heating.

- During cooling and dry: Present temperature is raised 1°C in an hour (when the timer is set), and 2°C raise in two hours. Then the temperature doesn't change ever.
- During heating: Present temperature is lowered 1°C in an hour (when the timer is set), and 2°C lower in two hours. Then the temperature doesn't change ever.

■ About FAN SPEED

- Capacity of the air conditioner can be selected by your choice. During heating or cooling.

| Operation capacity by your choice | FAN SPEED |
|---------------------------------------|-----------|
| Set automatically by microcomputer | AUTO |
| Powerful operation with high capacity | HI |
| Standard operation | MED |
| Energy-saving operation | Lo |

■ About power-off memory function

- When the air conditioner disconnects the power suddenly and restarts it, the air conditioner operates at the mode it did before power suddenly failed.
- The wire control doesn't have this function.

These are not failures

Room air is smelly.

A bad odor comes from the air conditioner.

- Smells impregnated in the wall, carpet, furniture, clothing, or furs, are coming out. A white mist of chilled air or water is generated from the outdoor unit.

⚠ CAUTION

If any of the following conditions occur, stop the air conditioner immediately, set off the power switch, and contact the dealer.

- The indicator lamps flash rapidly (five times per second), you disconnect the unit with the power and then connect the unit with the power again after two or three minutes but the lamps still flash.
- Switch operations are erratic.
- The fuse is blown frequently or the circuit breaker is tripped frequently.
- Foreign matter or water has fallen inside the air conditioner.
- Any other unusual condition is observed.

TROUBLES AND CAUSES

(ABOUT REMOTE CONTROLLER)

Before you ask for service or repairs, check the following points.

| Setting change is impossible. | | |
|--|---|---|
| Symptoms | Causes | Reason and Disposal |
| The fan speed can not be changed. | ● Check whether the MODE indicated on the display is "AUTO." | When the automatic mode is selected, the air conditioner automatically selects the fan speed. |
| | ● Check whether the MODE indicated on the display is "DRY." | When dry operation is selected, the air conditioner automatically select the fan speed. The fan speed can be selected during "COOL" and "FAN ONLY", and "HEAT." |
| The Transmission Indicator ▲ never comes on | | |
| Symptoms | Causes | Reason and Disposal |
| The remote control signal is not transmitted even when the ON/FF button is pushed. | ● Check whether the batteries in the remote controller are exhausted. | The remote control signal is not transmitted, because the power supply is off. |
| The Display never comes On | | |
| Symptoms | Causes | Reason |
| The TEMP. indicator does not come on. | ● Check whether the MODE indicated on the display is "FAN ONLY." | The temperature cannot be set during fan only operation. |

HAND OVER TO CUSTOMERS

INSTALLATION MANUAL of indoor and outdoor unit must be handed over to the customers.

Please narrate the manual to the customers in details.

IMPORTANT SAFETY INFORMATION

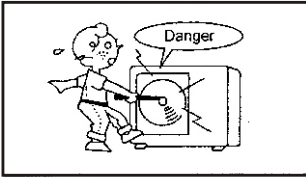

⚠CAUTION

Do not attempt to install this unit by yourself. This unit requires installation by qualified persons.

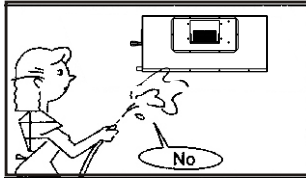

⚠DANGER

Do not attempt to service the unit yourself. This unit has no user serviceable components. Opening or removing the cover will expose you to dangerous voltage. Turning off the power supply will not prevent potential electric shock.

⚠DANGER

Never put hands or objects into the air outlet of indoor or outdoor units. These units are installed with a fan running at high speed. To touch the moving fan will cause serious injury.

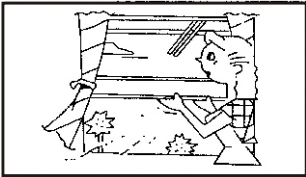

⚠DANGER

To avoid the risk of serious electrical shock. Never sprinkle or spill water or liquids on unit.

⚠WARNING

Ventilate the room regularly while the air conditioner is in use, especially if there is also a gas appliance in use in this room. Failure to follow these directions may result in a loss of oxygen in the room.

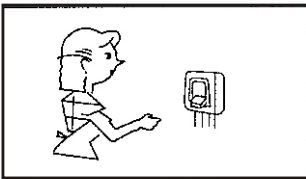

⚠WARNING

To prevent electric shock, turn off the power or disconnect the power supply plug before beginning any cleaning or other routine maintenance.

⚠WARNING

Do not use liquid cleaners or aerosol cleaners, use a soft and dry cloth for cleaning the unit. To avoid electric shock, never attempt to clean the units by sprinkling water.

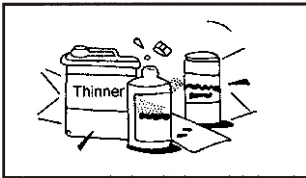

⚠CAUTION

Do not use caustic household drain cleaners in the unit. Drain cleaners can quickly destroy the unit components (drain pan and heat exchanger coil etc).

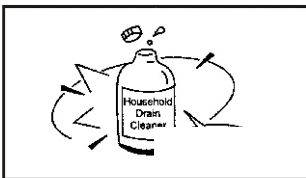

⚠NOTE

For proper performance, operate the unit in temperature and humidity ranges indicated in this owner's manual. If the unit is operated beyond these conditions, it may cause malfunctions of the unit or dew dripping from the unit.

INDOOR UNIT INSTALLATION

Choose installation location

- 1.A place where there are sufficient space for repair.
- 2.Hung ceiling that can bear the weight of the machine.
- 3.A place without air inlet and outlet is not hindered and without influence from outdoor air.
- 4.A place without heat source like smoke, fire or toxic pollution.
- 5.A place where air flow can be transmitted everywhere in the room.
- 6.A place convenient for installation.

Installation Space

Ensure sufficient space for installation and repair.

GENERAL: This INSTALLATION INSTRUCTION SHEET briefly outlines where and how to install the air conditioning system. Please read over the entire set of instructions for the indoor and outdoor units and make sure all accessory parts listed are with the system before beginning.

● Floor console

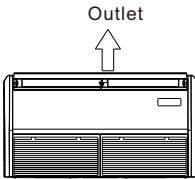

● Under ceiling

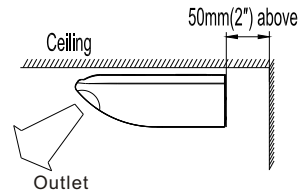
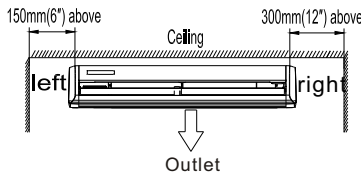

Installation procedure

Please remove the grille and the side board.

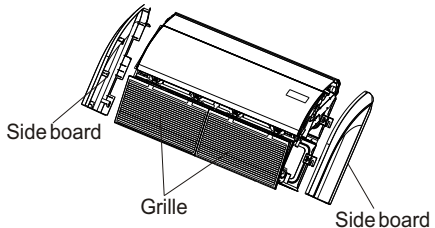

FLOOR CONSOLE TYPE

1. Select the piping and drainage directions.

The piping and drain can be made in two directions as shown below (fig.1).

When the direction is selected, please drill a 100mm (4") diameter hole on the wall, and the hole must be tilted downward towards the outdoor for smooth water flow. When the pipe is led out from the rear, make a hole in figure, at the position shown (fig.2).

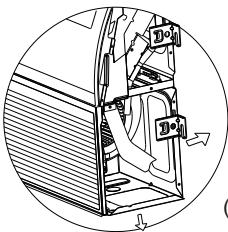

(Fig.1)

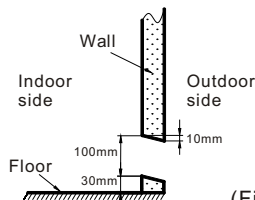

(Fig.2)

2. Drilling holes for anchor bolts and installing the anchor bolts (m10)

According to the position of the hole, install two expandable anchor bolts (A and B) at the position shown in the figure.

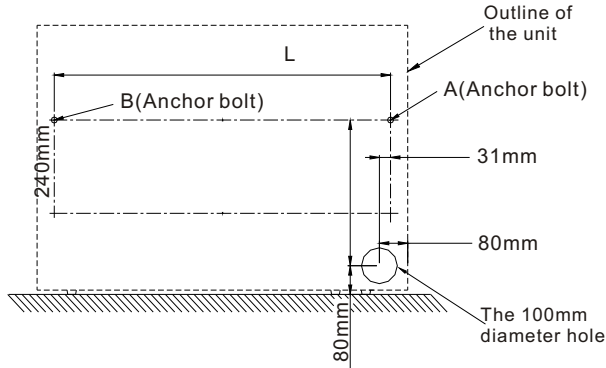

NOTE:

| Cooling Capacity | 18000 Btu/hr | 24000 Btu/hr | 36000 Btu/hr | 48000 Btu/hr |
|------------------|--------------|--------------|--------------|--------------|
| Dimension | | | | |
| L | 980mm | 980mm | 1200mm | 1560mm |

With a concrete drill, drill two 10mm diameter holes at the position (A and B) on the wall.

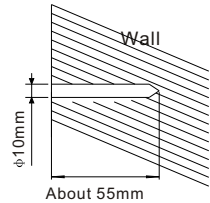

Insert the anchor bolts into the drilled holes, and drive the pins completely into the anchor bolts with a hammer.

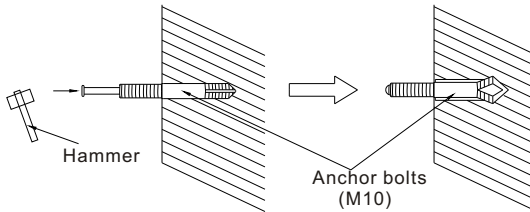

Install the unit to them with nuts, washers and spring washers
NOTE: The installation angle should not exceed 15 degrees.

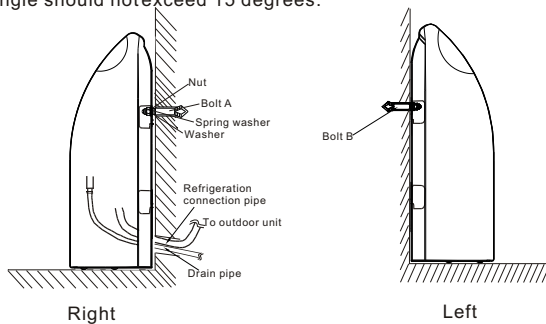

⚠ CAUTION

Be sure to arrange the drain hose so that it is leveled lower than the drain hose connecting port of the indoor unit.

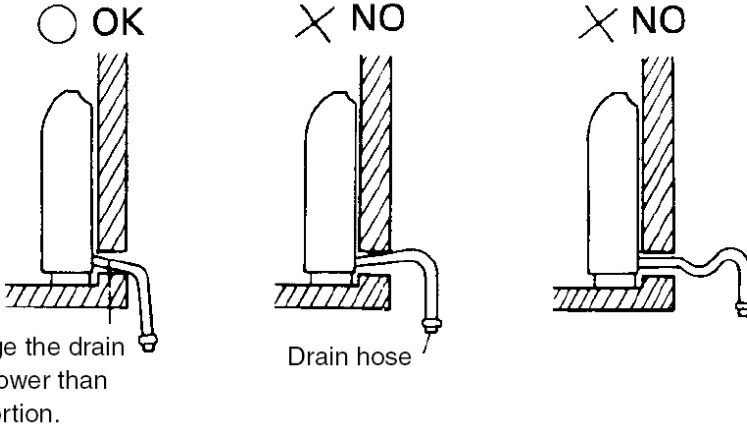

UNDER CEILING TYPE

1. Select piping and drain directions.

CAUTION: Install the drainage hose at the rear, it should not be installed on the top .

When the directions are selected, drill 80 mm (3-1/8") and 50 mm (2") or 150 mm (6") dia. hole on the wall so that the hole is tilted downward toward the outdoor for smooth water flow.

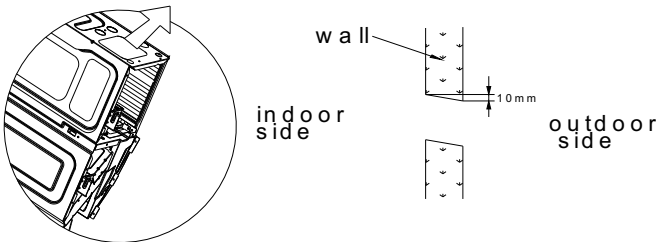

2. Drilling holes for anchor bolts and installing the anchor bolts(m10).

Please drill four holes for anchor bolts at the position A,B,C and D.

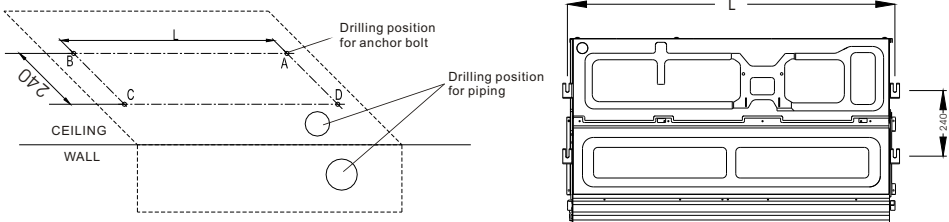

NOTE:

| Cooling Capacity Dimension | 18000 Btu/hr | 24000 Btu/hr | 36000 Btu/hr | 48000 Btu/hr |
|-------------------------------|-----------------|-----------------|-----------------|-----------------|
| L | 980mm | 980mm | 1200mm | 1560mm |

3. Installing indoor unit

Now, securely tighten nuts to each bolt with washers and spring washers.

NOTE: The installation angle should not exceed 10 degrees.

Mount the unit to the anchor bolts

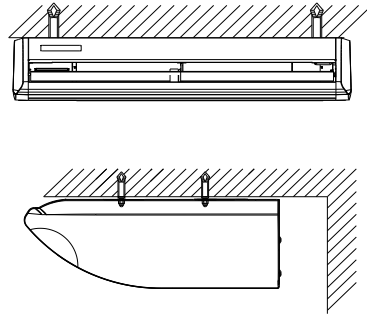
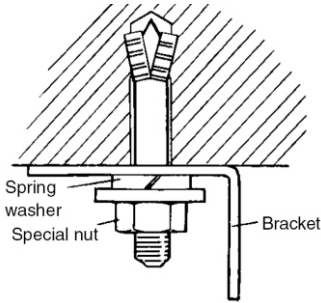

DRAINAGE PIPE CONNECTION

1. Installing the drain hose

Insert the drain hose into the drain pan, then secure the drain hose with a nylon fastener (we have connected the drain hose to the drain pan in the factory, you just need connect the drain pipe.).

Wrap the insulation (drain hose) around the drain hose connection.

Be sure to arrange the drain hose so that it is leveled lower than the drain hose connecting port of the indoor unit.

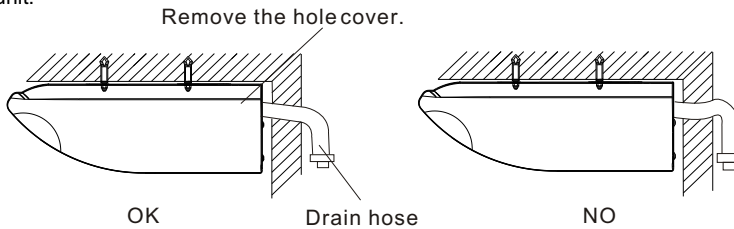

2. Drainage test

A. Check whether the drain pipe is unhindered and each joint is airtight.

B. Inject 2000ml water into the drain pan to test whether the water flows smoothly.

Choose installation location

🏠 INDOOR UNITS

1. A place where there are sufficient space for repair
2. Hung ceiling that can bear the weight of the machine.
3. A place without air inlet and outlet is not hindered and without influence from outdoor air
4. A place without heat source like smoke, fire or toxic pollution.
5. A place where air flow can be transmitted everywhere in the room.
6. A place convenient for installation.

🏠 OUTDOOR UNITS

1. A place where there is sufficient space for installation and repair.
2. A place where the air inlet and outlet are not hindered, without strong air flowing.
3. A dry and ventilated place.
4. A place where the overhanging is level and can bear the weight of the outdoor unit, without much noise.
5. A place where neighbours are not annoyed by noise and exhausted air.
6. A place without leakage of flammable gas.
7. A place convenient for installation.

Caution: (location in the following places may cause malfunction of the machine).

1. A place where there is flammable gas leakage.
2. there is salty air surrounding (near the coast)
3. there is caustic gas (the sulfide, for example) existing in the air.
4. a place where can not bear the weight of the machine
5. in kitchen where it is full of oil gas.
6. there is strong electromagnetic wave existing.
7. there is acid or alkaline liquid evaporating
8. a place where air circulation is not enough.
9. other special surroundings.

Figure of body size

Split type outdoorunit

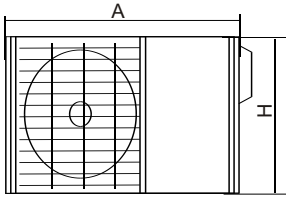

Fig.1

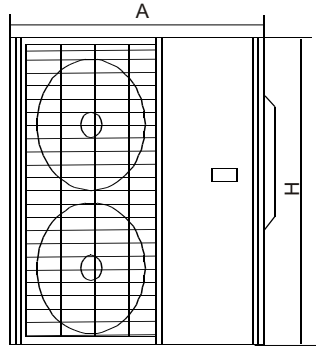
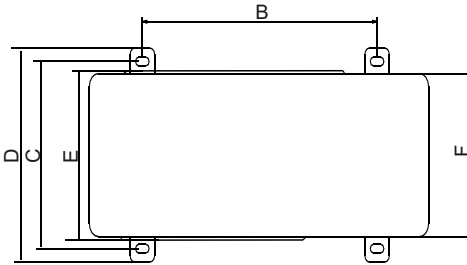

Fig.2



| MODE | A | B | C | D | E | F | H | REMARK |
|-------|-----|-----|-----|-----|-----|-----|------|--------|
| 18 | 780 | 521 | 290 | 328 | 290 | 288 | 605 | Fig.1 |
| 24 | 900 | 753 | 349 | 399 | 315 | 304 | 650 | Fig.1 |
| 36 | 940 | 600 | 375 | 400 | 340 | 338 | 885 | Fig.1 |
| 48/60 | 940 | 600 | 375 | 400 | 340 | 338 | 1250 | Fig.2 |

OUTDOOR UNIT INSTALLATION

Move outdoor unit in

1. Please use 4 pieces of 6mm steel wire hanging the outdoor unit up and move in.
2. To avoid the outdoor unit is out of shape, please add the baffles at the surface of outdoor unit where the steel wire rope may touch.
3. After moving, please remove the tray wood on the bottom.

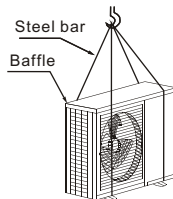

INSTALLATION SPACE

1. After leaving repair space as illustrated below, install the outdoor unit with power supply equipment installed at the side of the outdoor unit. Please refer to ELECTRIC SUPPLY INSTALLATION MANUAL for the installation method.
2. Please make sure necessary space for installation and repair.

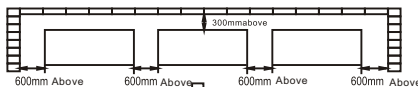
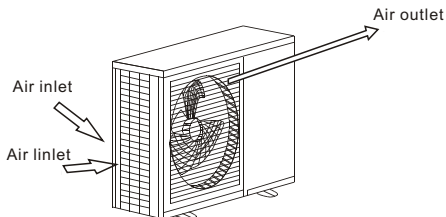

Air outlet of the outdoor unit
Overview of the outdoor unit

! No obstruction from the air outlet of outdoor unit

- At least 600mm space must be left between outdoor units as the sketch indicated.

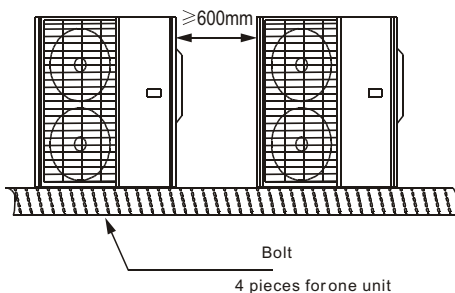
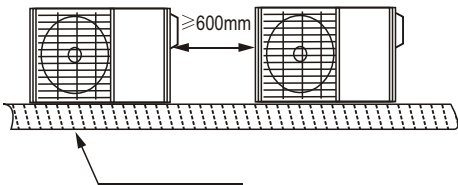

Refrigerant pipe

1. The junction is inside the cover of the right panel, please take off the cover first.
2. The pipe gets out of the side gap of the cover.
3. After connecting from the valve gap, reinstall it from left, right or backwards for installation.
4. The right picture is the sketch map of valve installation board of outdoor. Gas-side (low pressure) is the one upward, liquid side is the one downward.

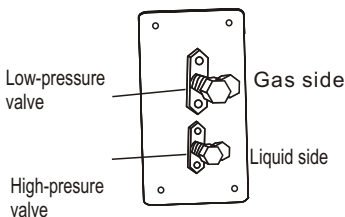

INSTALLATION

Pre-installation precautions

- Please confirm that the installation personnel are qualified in relevant installation service. If the air conditioner was installed by persons without special skills, normal operations would not be ensured, even the personal and estate safety would be affected.

User guideline

- The user's installation site should be provided with regular power supply in conformity with that indicated in nameplate of the air conditioner, and its voltage should be within a range 90 %~ 110 % of the rated voltage value.
- Power circuit should be equipped with protector, such as electricity leakage protector or air switch, which should possess a capacity greater than 1.5 times the maximum current value of the air conditioner.
- Never fail to adopt personal circuit and effectively-grounded socket compatible with the attached plug of the air conditioner. The attached plug is equipped with grounding pin, and it must not be modified as desired.
- Please adopt the fuse or circuit breaker prescribed in Installation Instructions.
- Only qualified electrician is allowed to carry out wiring tasks strictly according to electric safety requirements.
- Do ensure good earth of air conditioner, in other words, the main power switch of air conditioner must be connected to reliable ground wire.

Precautions

- The air conditioner should be installed securely; otherwise poor installation may lead to abnormal noises and vibration.
- Outdoor unit should be installed at a spot ensuring that its air outlet noises and hot exhaust will not violate your neighbors.

Unit body installation

Please confirm the indoor unit dimension according to the picture below
M10 whorl is to be installed.(4 sets)

- ◆ please refer to the following for the center distance between the bolts
- ◆ M 10 whorl is used
- ◆ please consult professional for your specific ceiling arrangement.

1. Dismantle scale of the ceiling.....please keep ceiling its level. Strengthen the beam to avoid vibration.
 2. Break the beam of the ceiling
 3. Strengthen the breaking point of the ceiling and reinforce the ceiling beam.
- ◆ After the main body hanging is finished, arrangement of pipe and line will be done in the ceiling. The direction of the pipe is determined after the installation location is chosen. If the ceiling has existed, please arrange the refrigerant pipe, drainage pipe, indoor and outdoor connecting line.
 - ◆ Installation of the hanging screw bolt

REFRIGERANT PIPE INSTALLATION

Pipe dimension and ways of installation

Outdoor pipe dimension and ways of install (in sequence of cooling capacity)

| Pipe Material | | Copper Pipe for Air Conditioner | | |
|---------------|-------------|---------------------------------|---------------|----------------|
| Model | | 14K-19K | 23K-28K | 30K-60K |
| Size(mm) | Liquid side | 6.35(1/4inch) | 9.52(3/8inch) | 9.52(3/8inch) |
| | Gas side | 12.7(1/2inch) | 15.8(5/8inch) | 19.05(3/4inch) |

| Conventional pipe, cooling capacity 14000~30000Btu/h | | Allowed value |
|--|---|---------------|
| Longest pipe(L) | | 35m |
| Maximum height drop | Height drop between indoor and outdoor unit | 20m |

| Conventional pipe, cooling capacity ≥ 30000Btu/h | | Allowed value |
|--|---|---------------|
| Longest pipe (L) | | 50m |
| Maximum height drop | Height drop between indoor and outdoor unit H | 25m |

Please refer to refrigerant pipe connection for detail.

Allowed length and height drop

Remove objects and water

- Use high-pressure nitrogen to clean the pipe instead of outdoor refrigerant.
- Before installing refrigerant pipe, please clean the pipe in case of foreign objects.

Additional refrigerant charge

The additional charge is base on the diameter and length of outlet/inlet liquid type . This AC has been charged with that for 5m pipe, those beyond 5 m should recharge as follows.

| Liquid pipe diameter | φ 1/4 " | φ 3/8 " | φ 1/2 " |
|--------------------------------------|---------|---------|---------|
| Additional charge for 1m pipe(R410A) | 0.022kg | 0.054kg | 0.110Kg |
| Additional charge for 1m pipe(R22) | 0.020kg | 0.050kg | 0.080Kg |

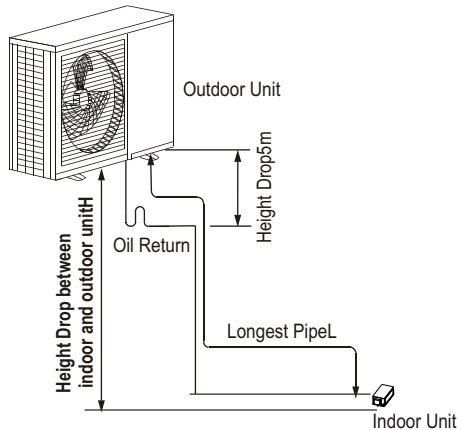

FLARING

- ① Cut the refrigerant pipe off with pipe cutter.

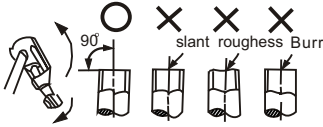

- ② Flaring after putting the pipe into connection nut.

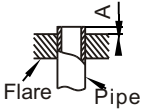

| Outside Diameter | A (mm) | |
|------------------|--------|------|
| | MAX | MIN |
| 1/4" | 8.7 | 8.3 |
| 3/8" | 12.4 | 12.0 |
| 1/2" | 15.8 | 15.4 |
| 5/8" | 19.0 | 18.6 |
| 3/4" | 23.3 | 22.9 |

Stop valve operation item

- Open the valve rod til to the position rod.
Do not try to open larger.
 - Fasten the bonnet with spanner or similar tools.
 - Fasten the bonnet of valve rod.
- Liquid side(3/8" , 1/2"): 1180Nc m(120kgfcm)
gas side(5/8" , 3/4"): 1180Nc m(120kgfcm)

- When vacuum pump is used, each low-pressure valve must be manipulated as follow
Please refer to operation manual for the usage of manifold valve.

1. Connect the recharged hose to lower pressure valve junction (low/high pressure valve must be tightened.)
2. Connect the charged hose junction with vacuum pump.
3. Open the low pressure handler of manifold fully.
4. Start vacuumizing with vacuum pump. When vacuumizing begins, loosen the nut of low pressure valve a bit. Check if the air enters (noise of vacuum pump changes, the all-purpose meter indication change from negative to zero), then tighten the nut of connection pipe.
5. After vacuumizing finishing, tighten the low pressure handler of manifold valve fully and stop the vacuum pump. When vacuumizing is carried out for over 15 minutes, please confirm if the all-purpose meter points at -1.0×10^5 Pa (-76cmHg).
6. Open the high/low pressure valve fully.
7. Dismantle the recharged hose from charge gap of low pressure valve.
8. Tighten the bonnet of low-pressure valve.

Junction fixture

- Aim at connection pipe
fix the nut of connection pipe, then tighten]
as the following diagram with spanner

Notice

- According to installation conditions, overlarge wrenched torch will destroy the nut. (Unit. N.cm)

| Outside diameter | Stengthen to fasten the torch |
|------------------|------------------------------------|
| 1/4" | 1420~1720N cm (144~176kgf.cm) |
| 3/8" | 3270~3990N cm (333~407kgf.cm) |
| 1/2" | 4950~6030N cm (504~616kgf.cm) |
| 5/8" | 6180~7540N cm (630~770kgf.cm) |
| 3/4" | 9720~11860N cm (990~1210kgf.cm) |

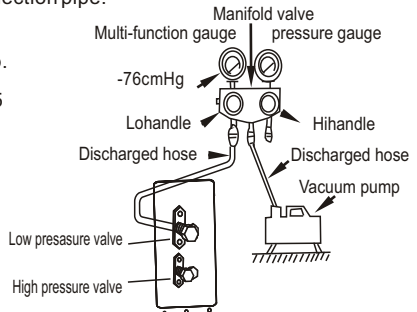
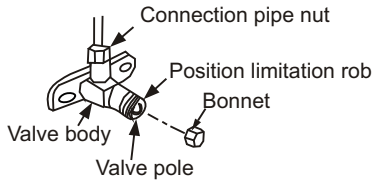
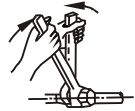

ELECTRIC WIRING

WARNING

Specified power cables should be used. Do not apply any pressure on the terminals used to connect.
Improper connection may cause fire.



Grounding must be properly done.
The grounding wire should be away from gas pipes, water pipes, telephone, lightning rods or other grounding wires. Improper grounding may cause electric shock.



Electric Wiring must be done by professionals. Use a separate circuit according to national regulations.



The temperature of refrigerant circuit will be high, please keep the interconnection away from the copper tube.

If the wiring capacity is not enough, electric shock or fire may occur.

If the supply cord is damaged, it must be replaced by the manufacturer or its service agent or a similarly qualified person in order to avoid a hazard.

An all-pole disconnection switch having a contact separation of at least 3mm in all poles should be disconnected in fixed wiring.

CAUTION

Be sure to install Current Leakage Protection Switch. Or electric shock may occur.

- Power cord is to be selected according to national regulations.
- Outdoor unit power cord should be selected and connected according to the outdoor unit installation manual.
- Wiring should be away from high temperature components, or the insulation layer of the wires may melt down.
- Use wire clamp to fix the wires and terminal block after connection.
- Control wire should be wrapped together with heat insulated refrigerant pipes.
- Connect the indoor unit to power only after the refrigerant has been vacuumed.
- Don't connect the power wire to the signal wire connection end.



Notice

1. Power cord indicates the supply cable from indoor air switch to indoor unit or outdoor unit.
Indoor/outdoor power connecting wire indicates the supply cable connecting indoor unit and outdoor unit.
2. Cross-section area of power cord wire is the minimum value here. In case power-connecting wire is longer than usual, just select the conductor cross-section a level higher than the specified one to avoid voltage drop.
3. The cross section of ground wire for the whole set of air conditioner should be 2 mm^2 at least.
Power cord connected to indoor unit should be cable RVV (300 / 500); the power cord connected to outdoor unit and the indoor/outdoor power connecting wire should be multi-wire strand cable (neoprene) YZW (300 / 500V).
4. In case single-core double-layer wire is adopted, its cross section should be one level bigger than the specified one, and the wire should be covered with dedicated electric sheath.

1. Wiring method for indoor unit: Open the electric junction box to carry out wire connection. Notice that the connecting wire should be passed through wire-inlet rubber ring of the box. Connect the wires according to stipulations in the wiring diagram, and the wire splices at connecting terminal should be tightly compacted, free of looseness.

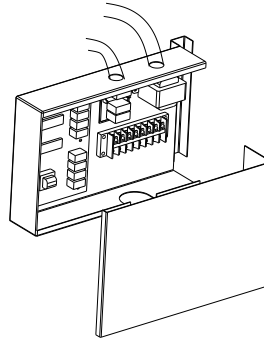

2. Binding treatment

Once the connecting wires have been properly connected, bind the connecting tubing, connecting wire and drain pipe by binding tapes

After binding treatment, the cross section is shown in the figure below:

Notice: Drain pipe must not be flattened during binding treatment.

Drain pipe outlet should be led to a place that can avoid affecting the environment.

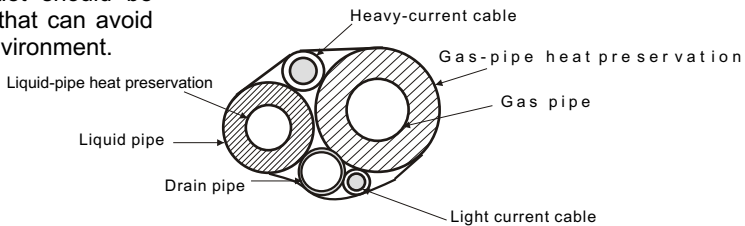

If situations as follow occur, please cut off the electric power before contacting the dealer

- open or close incorrectly
- fuse or electric leakage protector breaks for several times.
- Objects or water into the AC

3、 outdoor unit wiring

1. Copper-cored wire should be selected.
2. As the electric control box is inside the unit body, dismantle the valve installation cover, top cover right front board sequenly when connecting wires. Then connect the responding wires from the hole of the electric of the right back board.
3. mate series number according to junction box of outdoor unit. (Disposed length of connection wire is good enough for inserting the conenction pole completely as the right picture shows.)
4. Wrap the electric wire(conductor),which is not inserted into the connection pole, with PVC belt and make it avoid any electric appliance or metal elements.
5. After installing cable connection lug on the main power wire, then connect to the terminal row.
6. Connection lug should be installed on the grounded wire of all cables.
Only finishing that all cables can be connected to grounded bolt.
7. The electric wire from wire terminal should be through wire clips.
8. Please refer to the right illustration.

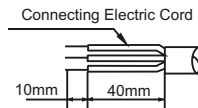

NOTICE

The indoor unit should be connected correctly with the high-pressure and low-presurre stop valve of the outdoor unit as well as the signal line. Otherwise, some electrical componets and system may suffer damages.

TRY TEST

Before testing

- a. Check if piping, drainage and external wiring have been finished correctly.
- b. Check if the power supply complies with requirements; if there is refrigerant leakage; if the all wires and cables are correctly connected and well fixed.

Function test

- a. After checking, energize your appliance and press the buttons on the control panel to see if the buttons function;
- b. If LCD screen displays normally.

Notes

1. Please read this operating and installation instructions carefully.
2. Do not let air in or refrigerant out during installing or reinstalling the appliance.
3. Test run the air conditioner after finishing installation and keep the record .
4. Type of fuse for controller of indoor unit is 50T, rated specification is T 5 A, 250V.
Fuse for the whole unit is not supplied by the manufacturer, so the installer must employ a suitable fuse or other over-current protective device for the power supply circuit according to the maximum power input as required.
5. The air conditioner operates safely when ambient static pressure is 0.8~1.05 standard atmosphere pressure.

TROUBLESHOOTING

1. Trouble display of indoor display panel

Infrared signal receiver: receive the signal from the remote controller.

To make your remote controller operation more efficient, please let remote controller emitter aim at infrared signal receiver.

Buzzer: firstly powersupplied or any of remote controller operations will make the buzzer sound once.

Some obstacles occurring in the system will be recognized by intelligent recognition system of unit, lighting on the DISPLAY PANEL flashing show the type of obstacles.

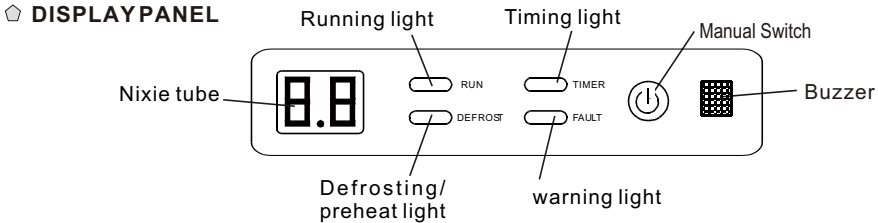

Display function declaration :

LED light the state of running light

When powered-on the first time, the running light twinkles, while the double-8 does not lit.

When started-up normally, the running light lights on, while the double-8 shows the designed temperature.

When operated normally, the running light lights on, while the double-8 shows the designed temperature.

When closed down, both LED and double-8 are gone out.

LED light the state of Timing light

When timing set, the timing light lights on, and the double-8 flash shows the time setting within 5 seconds, then shows the designed temperature.

When without time setting, the timing light gone out, while the double-8 back to the original state.

LED light the state of defrosting/preheat light

When in the state of defrost, oil return, cold-wind proof, the defrosting/preheat light lights on, while the double-8 shows the designed temperature. (One-driven-one does not show the oil return state).

When out of the state of defrost, oil return, cold-wind proof, the defrosting/preheat light gone out, while the double-8 shows the designed temperature. (One-drive-one does not show the oil return state).

LED light the state of warning light

When double-8 shows E* or P*, the running lights gone out, while the warning light lights on.

2. Trouble display of outdoor unit

- (1) During standby, the digital tube displays the numbers of indoor unit currently connected and communicating.
- (2) When the compressor operates, the digital tube displays the frequency value of the inverter compressor;
- (3) The digital tube displays "dxx" during defrosting;
The digital tube displays "Cxx" during oil return
- (4) During trouble protection, the information code displayed by the digital tube is as follows:

| The display content of indoor LED | The display content of outdoor LED | The definition of failure or protection |
|-----------------------------------|------------------------------------|---|
| E0 | E01 | Bus communication fault of indoor and outdoor unit |
| EC | E03 | Inverter module communication fault of outdoor unit |
| E4 | E04 | Phase order protection fault(main pcb) |
| E7 | E05 | Outdoor temperature sensorfault |
| E4 | E06 | Temperature sensor fault in the middle part of condenser |
| E3 | E07 | Defrost temperature sensorfault |
| E4 | E12 | Back temperature sensorfault(ts) |
| E8 | E13 | Exhaust temperature sensorfault of compressor |
| E4 | E21 | Reversing fault of 4-way valve (heating mode) |
| EE | E23 | EEPROM fault (outdoor unit E2 fault) |
| E4 | E30 | The unit type is wrong chose by the outdoor dial-up |
| E1 | E32 | Indoor temperature sensor Ta |
| E2 | E33 | Inner disc tube temperature sensor Tm |
| E4 | E34 | High pressure switch fault (when rate is 0, open circuit) |
| E4 | E35 | Low pressure switch fault (when rate is 0, open circuit) |
| P1 | P01 | low -voltage protection |
| P0 | P03 | Inverter module protection |
| P3 | P04 | High pressure switch protection |
| P4 | P09 | Inverter compressor exhaust high temperature protection |
| P6 | P12 | Condenser high temperature protection |
| P2 | P13 | Inverter compressor current protection |
| P3 | P21 | Low pressure switch protection |
| P3 | P26 | IPM module overcurrent protection |
| P3 | P27 | IPM module low voltage protection |
| P3 | P28 | IPM module high voltage protection |
| P5 | P31 | Indoor coiler temperature protection |
| P8 | P33 | Too high or too low protection for outdoor temperature |
| P3 | P34 | Drive radiator temperature protection |