



CONTENTS

PRECAUTION	01
PARTS AND FUNCTIONS	03
FUNCTION AND OPERATION OF PANEL'S PARTS	04
DISPLAY PAHEL	05
INDOOR UNIT INSTALLATION	07
INSTALLATION OF PANEL	13
Figure of body size	15
OUTDOOR UNIT INSTALLATION	16
REFRIGERANT PIPE INSTALLATION	18
ELECTRIC WIRING	21
ADJUSTING AIR FLOW DIRECTION	25
IMPORTANT SAFETY INFORMATION	26
REMOTE CONTROLLER	27
TROUBLESHOOTING	33

PRECAUTION

- Read the following " PRECAUTIONS" carefully before installation.
- The caution items stated here must be followed because these important contents are related to safety. The meaning of each indication used is as below.
Incorrect installation due to ignoring of the instruction will cause harm or damage, and the seriousness is classified by the following indications.

 WARNING	This indication shows the possibility of causing death or serious injury.
 CAUTION	This indication shows the possibility of causing injury or damage to properties only.

NOTE :

1. Injury means causing harmed, burned, electrical shocked, but not serious for hospitalization.
 2. Damage of property means disrepair of property, material.
- Carry out test running to confirm that no abnormality occurs after the installation. Then, explain to user the operation, care and maintenance as stated in instructions. Please remind the customer to keep the operating instructions for future reference.

 WARNING
<ul style="list-style-type: none"> ● Engage dealer or specialist for installation. If installation done by user is defective, it will cause water leakage, electrical shock or fire.
<ul style="list-style-type: none"> ● Install according to this installation instructions strictly. If installation is defective, it will cause water leakage, electrical shock or fire.
<ul style="list-style-type: none"> ● Use the attached accessories parts and specified parts for installation. Otherwise, it will cause the set to fall, water leakage, fire or electrical shock.
<ul style="list-style-type: none"> ● Install at a strong and firm location which is able to withstand the set's weight. If the strength is not enough or installation is not properly done, the set will drop and cause injury.
<ul style="list-style-type: none"> ● For electrical work, follow the local national wiring standard, regulation and this installation instructions. An independent circuit and single outlet must be used. If electrical circuit capacity is not enough or defect found in electrical work, it will cause electrical shock or fire.
<ul style="list-style-type: none"> ● When carrying out piping connection, take care not to let air or other substances other than the specified refrigerant go into refrigeration cycle. Otherwise, it will cause lower capacity, abnormal high pressure in the refrigeration cycle, explosion and injury.
<ul style="list-style-type: none"> ● Grounding is necessary. It may cause electrical shock if grounding is not perfect.
<ul style="list-style-type: none"> ● Do not install the unit at place where leakage of flammable gas may occur. In case gas leaks and accumulates at surrounding of the unit, it may cause fire.

Operating condition

The protective device maybe trip and stop the unit within temp range listed below:

HEATING	Outdoor air temperature is over 21 °C
	Outdoor air temperature is below -7 °C
	Room temperature is over 31 °C
COOLING	Outdoor air temperature is over 43 °C
	Room temperature is below 17 °C
DRY	Room temperature is below 18 °C

If the air conditioner runs for a long time in "COOLING" or "DRY" mode at air relative humidity higher than 80% (doors or windows opened), dew may generate and drip near airoutlet.

Noise pollution

- Install the air conditioner in a place that can bear its weight in order to operate more quietly.
- Install the outdoor unit in a place where the air discharged and the operation noise do not annoy your neighbors.
- Do not place any obstacles in front of the outlet of the outdoor unit for fear it affects operation and increases the noise level.

Features of Protector

- 1 The protective device will trip at following cases.
 - Stop the appliance and restart it at once or change other modes during operation, you have to wait 3 minutes before restarting.
 - After switching on the power circuit breaker and then turn on the air conditioner at once, you have to wait about 20 seconds.
- 2 In case all operations have stopped, you need
 - Press "ON/OFF" button again to restart it.
 - Set TIMER once again if it has been canceled.

Inspection

- After a long time of operation, the air conditioner should be inspected for the following items.
- Abnormal heating of the power supply cord and plug or even a burnt smell.
 - Abnormal operating noise or vibration.
 - Water leakage from indoor unit.
 - Metal cabinet electrified .
-  Stop using the air conditioner if above problem happened. It is advisable that the air conditioner should be given a detail check-up after using for five years even if none of the above happen.

Feature of HEATING mode

Preheat

2-5 minutes are necessary to preheat the indoor heat exchanger at the beginning of "HEATING" operation, lest cold air be discharged.

Defrost

In "HEATING" operation the appliance will defrost automatically. This procedure lasts 2~10 minutes, then returns to "HEATING" mode automatically. During defrosting, indoor fan stop running and return to heating mode operation automatically when defrosting has finished.

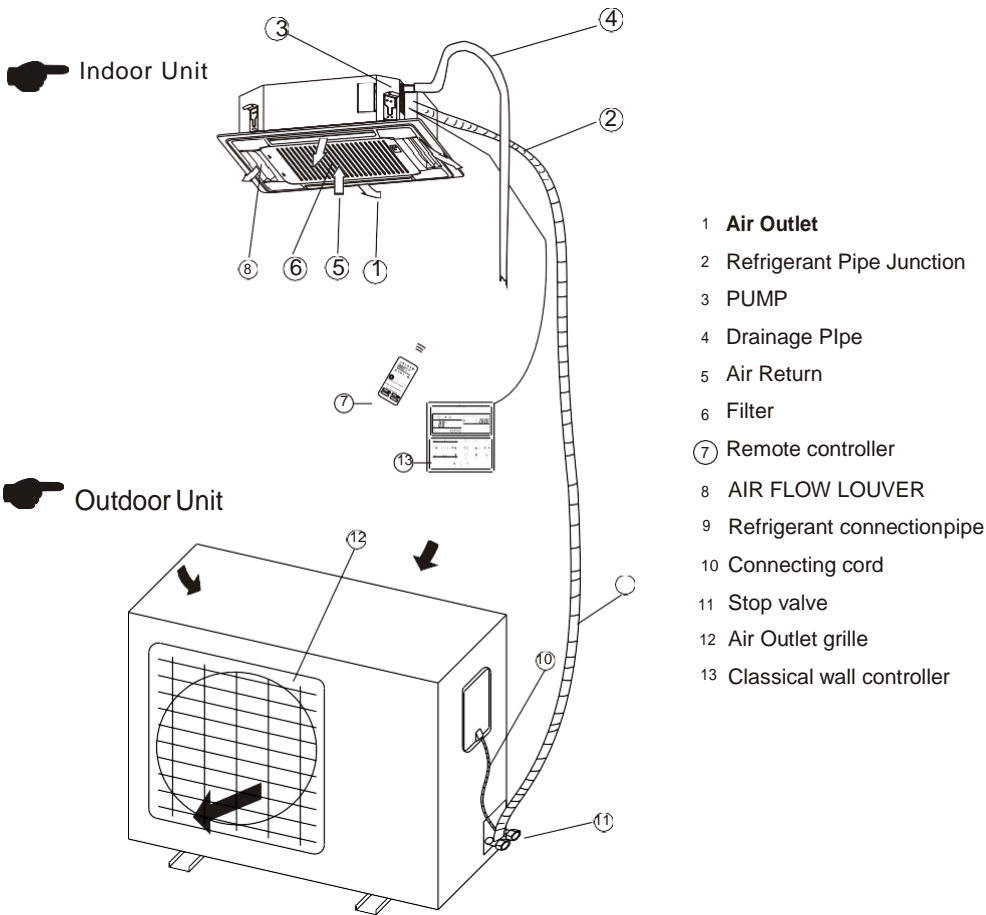

Requirements

- The air conditioner cannot be started up until it is powered on for 2 hours. Furthermore, in case of a shutdown lasting for about one diel only, please do not cut off the electricity supply. (it is necessary to heat the crankcase heater so as to avoid force start of compressor.)
- Notice that the air inlet/outlet must not be choked up. If chokeup takes place, the air conditioner behavior may be affected, or air conditioner cannot run because of actuation of protector.

FUNCTION AND OPERATION OF PANEL'S PARTS

NOTICE

Please adjust room temperature properly especially when the old men, children, patients stay at house.

Lightning and other electromagnetic radiation may cause ill effect .If it is ,please plug off the power switch ,and replug in ,then restart the unit.

Do not block the inlet of indoor unit or outlet of outdoor unit, any of blocks will reduce cooling or heating efficiency.

● CONSTITUTION OF PANEL

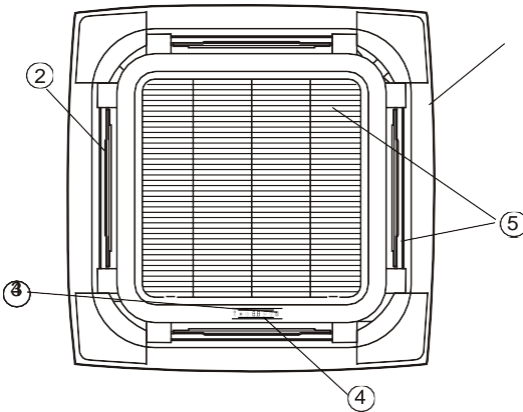

- 1.PANEL
- 2.AIR FLOW LOUVER
- 3.INFRARED SIGNAL RECEIVER
- 4.DISPLAY PANEL
- 5.AIR-IN GRILLE

2. It suits for Body dimension :580X255X380 cooling and heating pump type.

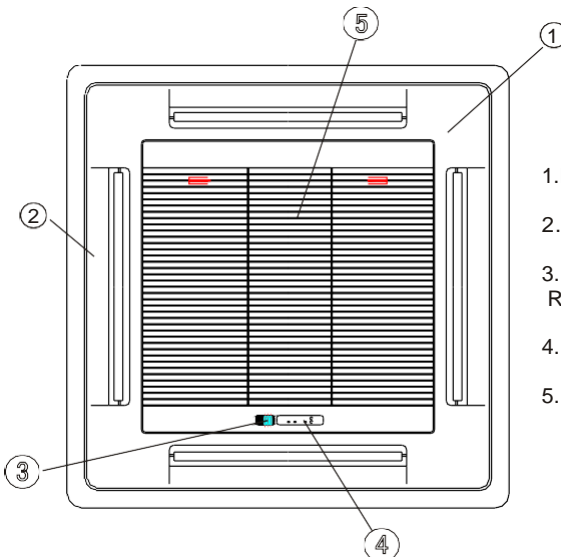

- 1.PANEL
- 2.AIR FLOW LOUVER
- 3.INFRARED SIGNAL RECEIVER
- 4.DISPLAY PANEL
- 5.AIR-IN GRILLE

DISPLAY PANEL

Infrared signal receiver: receive the signal from the remote controller.

To make your remote controller operation more efficient, please let remote controller emitter aim at infrared signal receiver.

Buzzer: firstly power supplied or any of remote controller operations will make the buzzer sound once.

Some obstacles occurring in the system will be recognized by intelligent recognition system of unit ,lighting on the DISPLAY PANEL flashing show the type of obstacles .

DISPLAY PANEL

1. It suits for Body dimension :830X230X830 or 830X310X830 cooling and heating pump type.

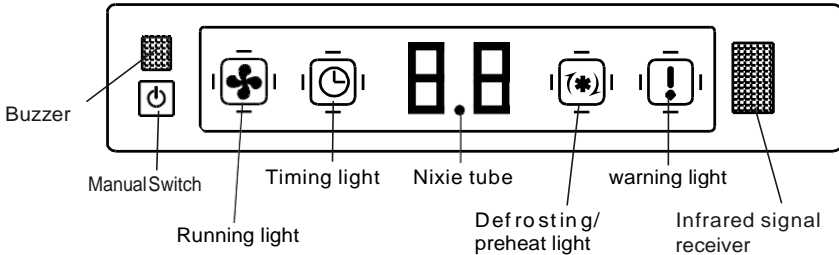

2. It suits for Body dimension :580X255X380 cooling and heating pump type.

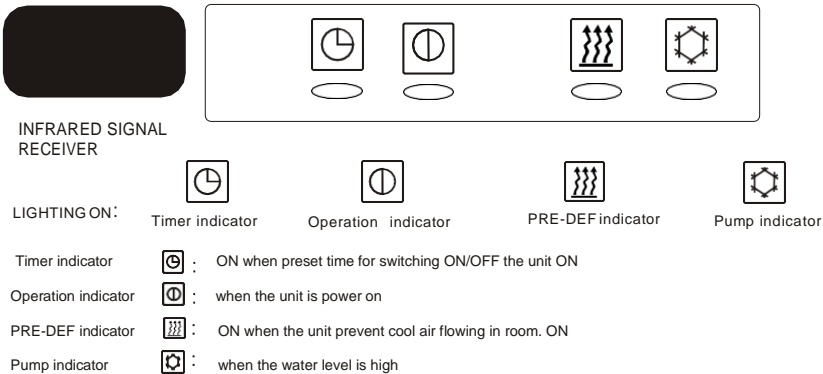

INDOOR UNIT INSTALLATION

(Please select the space to install indoor unit according to the dimension show above, then install correctly, and have enough space for maintenance.)

Select installation location considering piping and wiring connection after the Indoor Unit has been hanged. Then decide the piping wiring leading direction.

- Be sure to lead the refrigerant pipes, drain pipes and connection wires out to its connection location before hanging the unit if the opening on the ceiling has been decided.
- Confirm sizes of the indoor unit and ceiling opening with the attached installation paper pattern. (Please fix the paper pattern below the body with M5X16 screws (4).

18k (Body dimension : 580X255X580)

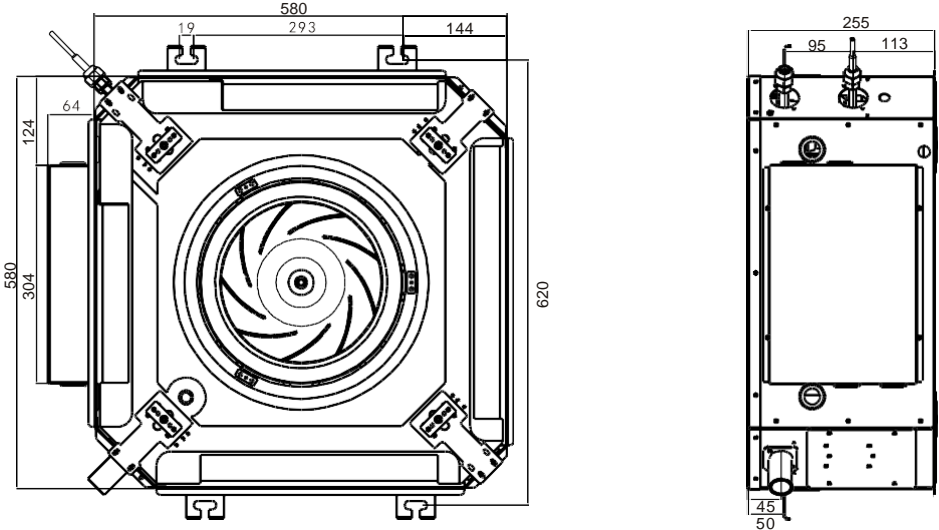

18/24k (Body dimension : 840X230X840)

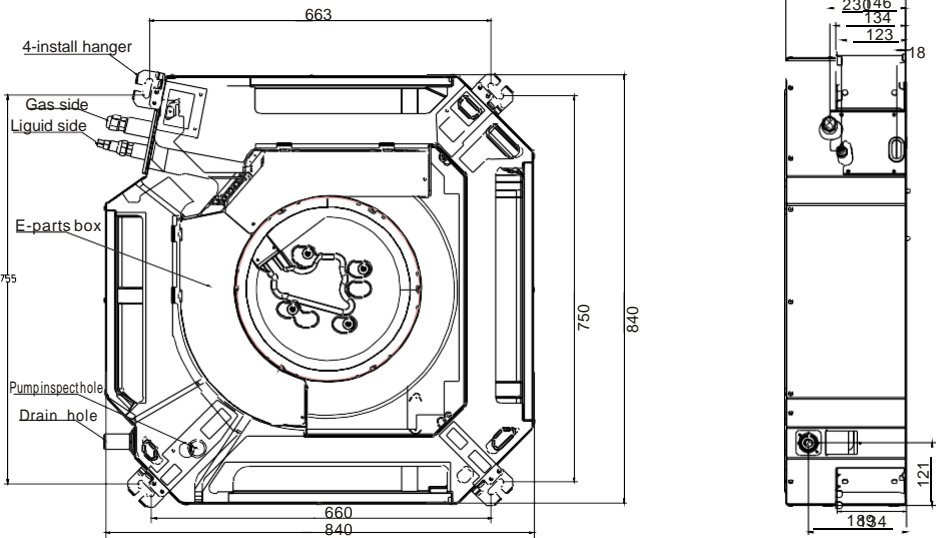

 36/48/60k (Body dimension : 840X300X840)

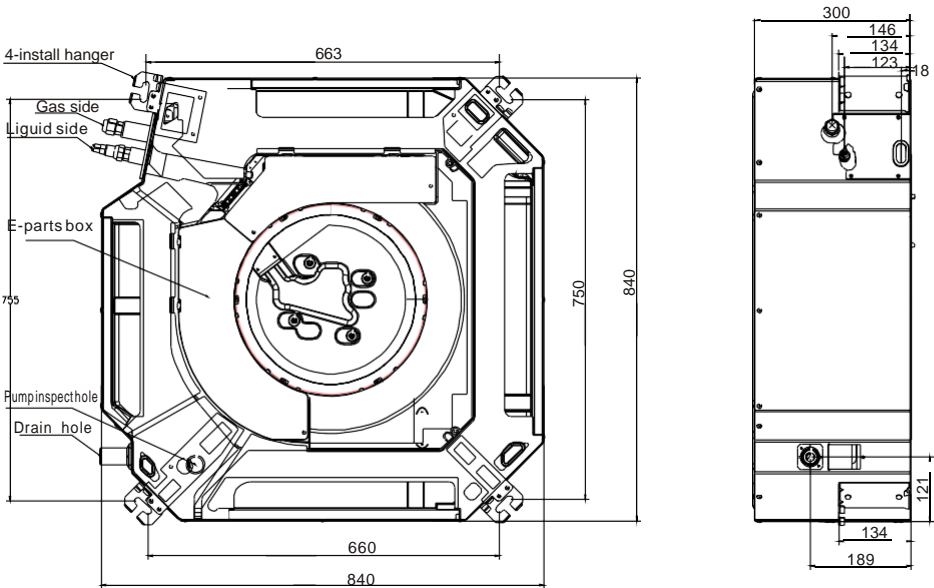

■ INSTALLATION LOCATIONS

▲ CAUTIONS

1. Location in the following places may cause malfunction of the machine. (If unavoidable, please consult your local dealer)
 - a. A place where there is flammable gas leakage.
 - b. There is salty air surrounding (near the coast).
 - c. There is caustic gas (the sulfide, for example) existing in the air (near a hot spring).
 - d. A place where can not bear the weight of the machine.
 - e. In kitchen where it is full of oil gas
 - f. There is strong electromagnetic wave existing.
 - g. There is acid or alkaline liquid evaporating.
 - h. A place where air circulation is not enough.
 - i. The appliance shall not be installed in the laundry
2. Electrical Insulation must be done on the air conditioner and the building complying to National Regulations.

■ INSTALLATION SPACE

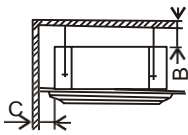
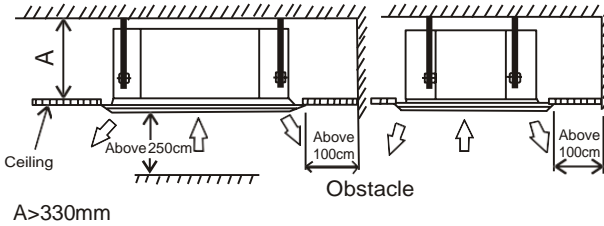

Wall material	Flammable material	Fire-proof material or other nonflammable materials other than metal	Fire-proof structure
Up(B)	Above 5cm	Above 5cm	Above 5cm
Sides(C)	Above 100cm	Above 100cm	————

■ HEIGHT BETWEEN CEILING AND FLOOR

The installation height between ceiling and floor must be 2.7m~3.2m.

■ CEILING HOLE AND THE HOOK INSTALLATION

Preparation Work on the Ceiling

- Installation method should be changed under the different construction structure. Please consult the professional for the detailed information.
- After opening a hole, the ceiling should be horizontal and strong to prevent vibration.
 - ① Cut the beams at the hole and remove them.
 - ② Reinforcing the beams that have been cut and the beams fixing the ceiling .

Installation of the hanging screw bolt

Bolt with M10 whorl is to be used. The center distance between the bolts is decided by the size of the unit . Use the following method to install:

Wooden construction

Put the square timber over the roof beam, then install the hanging screw bolts.

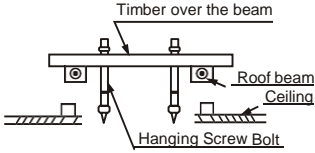

For finished concrete bricks

Install the hanging hook with expansible bolt into the concrete deep to 45~50mm to prevent loose.

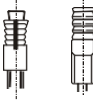

New Concrete Bricks

Inlaying or embedding the screw bolts.

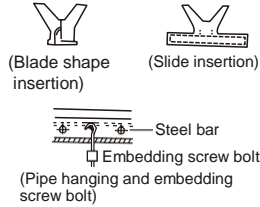

Steel roof beam structure

Install the supporting angle steel.

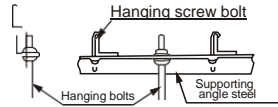

Overhanging the

Adjust the gasket (down side) to 90mm over the ceiling.

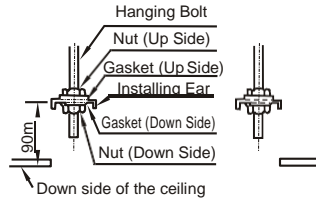

- Install the hanging bolt into T groove of the hanging tool. Overhang the indoor unit and ensure it is level using a level indicator.

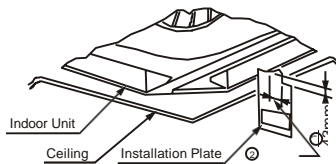
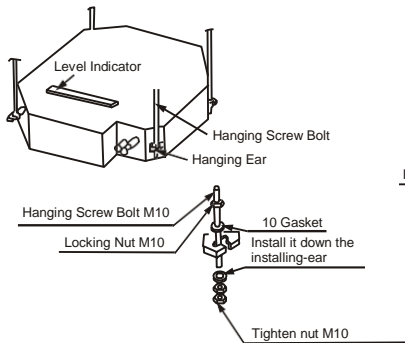

PANEL INSTALLATION

- Panel installation should be done after piping and wiring.
- Be sure that the indoor unit and ceiling hole installation size is right before installation.

CAUTION

Be sure to seal the connection parts between the panel - the ceiling and the panel - the indoor unit ,or even small gaps may cause wind/water leakage or condensing water.

DRAINAGE PIPE INSTALLATION

CAUTION

Be sure to follow Installation Manual during drainage installation, the drainage pipe must have the heat insulation to prevent condensing.

! CAUTION

- The drain pipe of indoor unit must have the heat insulation , or it will condense dew, as well as the connections of the indoor unit.
- The declivity of the drain pipe downwards should be over 2/100, and no winding and bending.
- The total length of the drain pipe when pulled out transversely shall not exceed 20m , when the pipe is over long, a prop stand must be installed every 1.5 to 2m to prevent winding.
- Refer to the following figures about the installation of the pipes.
- Do not impose any pressure on the connection part of the drainage pipe.

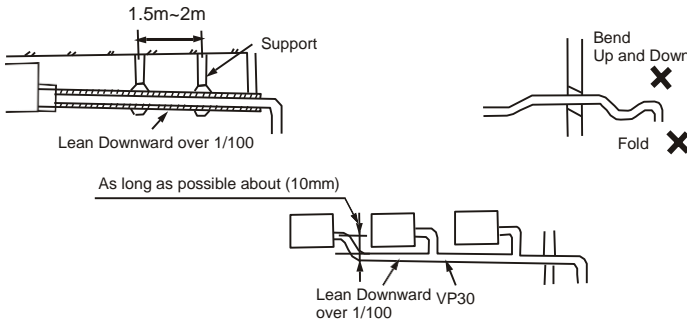

Drainage Pipe Material, Heat-

The listed material should be used:

Drainage Pipe Material	Polyvinyl chloride pipe (32mm outer diameter)
Heat Insulation Material	Foamed polyethylene insulation plate (10mm thickness)

Flexible

Measure diameter of the hard pipe using cutting method, and adjust the joining angle.

- Pull out the flexible hose, do not over deform than illustrated below.
- Be sure to bind it with the attached band.
- Please place the flexible hose horizontally.

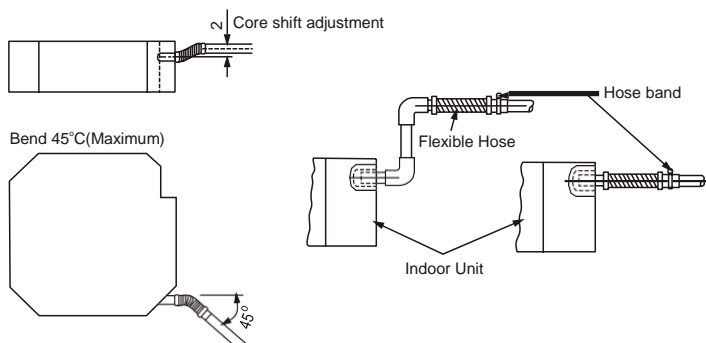

Connection

Connect the transparent pipe with the polyvinyl chloride pipe.

- Use polyvinyl chloride glue at the connection part of the drainage pipe, be sure no water leakage.
- Paste glue at the front 40mm of the polyvinyl chloride pipe, insert it into the transparent pipe.
- It needs 10 minutes for the glue to dry. Do not impose pressure on the connection during the drying period.

Heat

Wrap the flexible hose carefully with the attached heat insulation material from the start to the end (to indoor part)

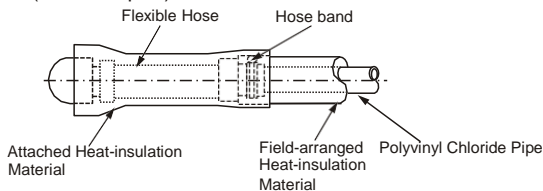

Drainage

To make sure that the drainage pipe would not be slanted downward, lead it upward to a height 360mm maximum, then downward lead it.

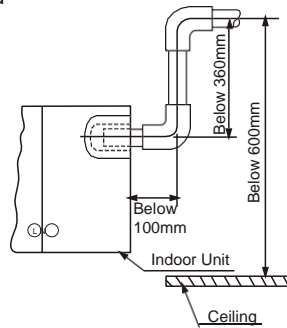

Drainage

- Check whether the drain pipe is unhindered before testing.
 - 1) Stow water from sprue to check.
 - 2) Stow 600cc water with pot or hose from sprue slowly , preventing touching the drain pump motor.
 - 3) After the preparation work , disconnect the water level switch ,power 220-240VAC to of terminal board, and the drain pump start up immediately.
 - 4) After drain pump run 2 min.,reset the water level pin, and the drain pump motor will stop after running 1 min..

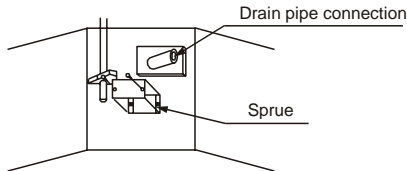

Motor Sound

- The drainage test is doing during checking the drain pump motor running sound .
- Reset the water level switch connection to the original position after the drainage test .

INSTALLATION OF PANEL

● BODY DIMENSION:

Unload air-in grille

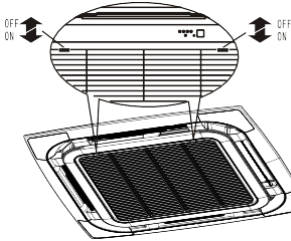

Take off air-in grille

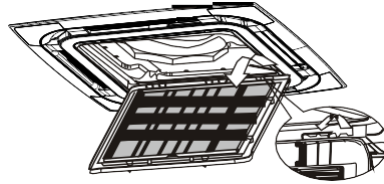

Unload panel installation cap

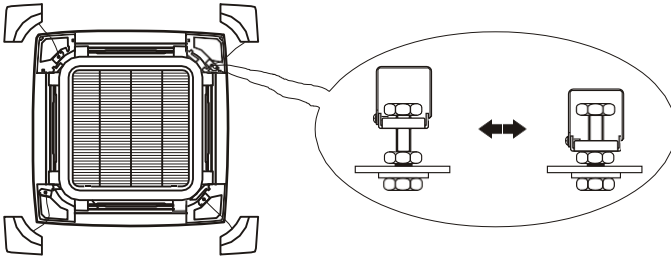

■ INSTALLATION OF PANEL

1. Please screw M10 gasket and M6*20 bolt at the corner of indoor unit, before screwing them fasten, screw other two additional bolts which locates red bolt showing as figure and notice that the direction of red arrow on the electrical box aligns the one on the panel.

2. Please connect step motor wire, display board wire to the electrical box according to ELECTRIC WIRING DIAGRAM on the electrical box.

3. Then screw the other two M6*20 bolt with M10 gasket through the hole of panel into outdoor unit

4. Adjust the location and direction of panel to tally louver of panel with outlet of outdoor, screw all the bolts fasten to make the panel and outdoor unit pressed together.

5. Return the air-in grille and panel back to the outdoor unit.

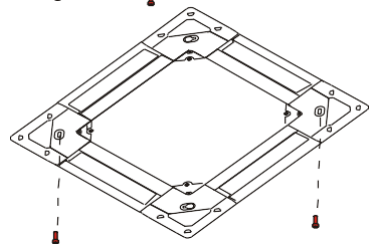
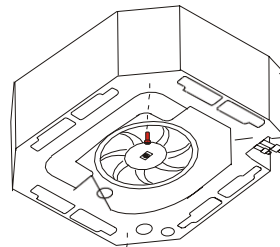

BODY DIMENSION:574X250X574

Unload air-in grille



INSTALLATION OF PANEL

1. Please screw M10 gasket and M6*20 bolt at the corner of indoor unit ,before screwing them fasten ,screw other two additional bolts which locates red bolt showing as figure and notice that the direction of red arrow on the electrical box aligns the one on the panel.
2. Please connect step motor wire,display board wire to the electrical box according to ELECTRIC WIRING DIAGRAM on the electrical box.
3. Then screw the other two M6*20 bolt with M10 gasket through the hole of panel into outdoor unit.
4. Adjust the location and direction of panel to tally louver of panel with outlet of outdoor,screw all the bolts fasten to make the panel and outdoor unit pressed together.
5. Return the air-in grille and panel back to the outdoor unit.

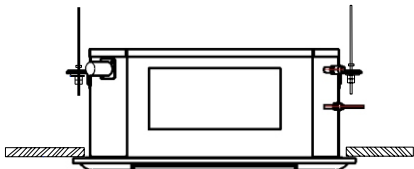
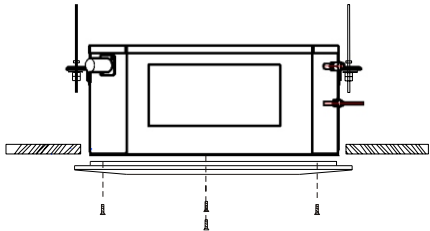
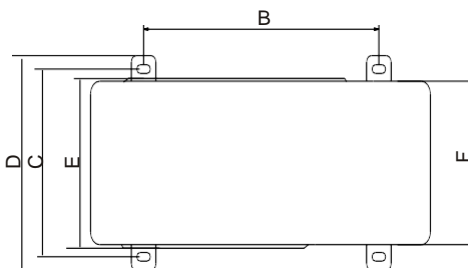
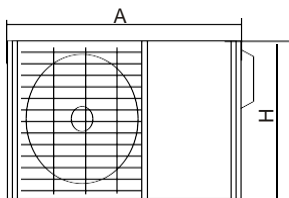
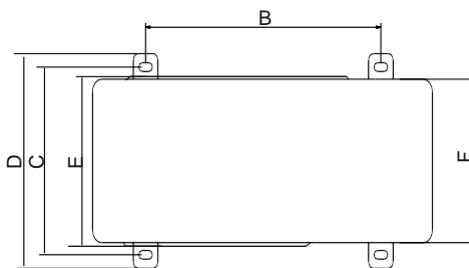
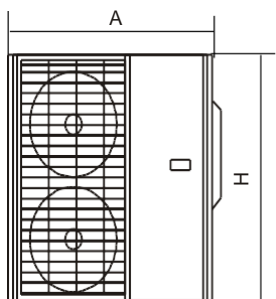

Figure of body size

Split type outdoor unit



MODE	A	B	C	D	E	F	H
18K	780	521	290	328	290	288	605
24K	900	753	349	359	315	304	650
36K	940	600	375	400	340	338	885



MODE	A	B	C	D	E	F	H
48K	940	600	375	400	340	338	1255
60K	940	600	375	400	340	338	1255

OUTDOOR UNIT INSTALLATION

Move outdoor unit

1. Please use 4 pieces of 6mm steel wire hanging the outdoor unit up and move in.
2. To avoid the outdoor unit is out of shape, please add the baffles at the surface of outdoor unit where the steel wire rope may touch.
3. After moving, please remove the tray wood on the bottom.

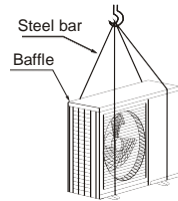

INSTALLATION SPACE

1. After leaving repair space as illustrated below, install the outdoor unit with power supply equipment installed at the side of the outdoor unit. Please refer to ELECTRIC SUPPLY INSTALLATION MANUAL for the installation method.
2. Please make sure necessary space for installation and repair.

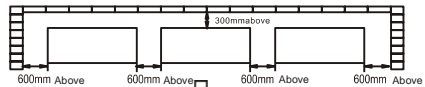
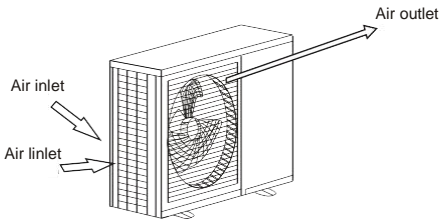

Air outlet of the outdoor unit
Overview of the outdoor unit

No obstruction from the air outlet of outdoor unit

- At least 600mm space must be left between outdoor units as the sketch indicated.

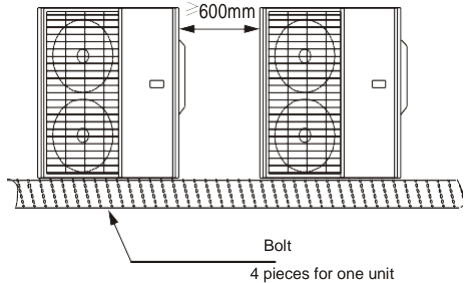
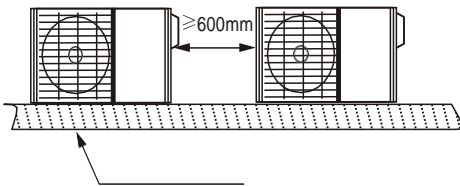

Refrigerant pipe

1. The junction is inside the cover of the right panel, please take off the cover first.
2. The pipe gets out of the side gap of the cover.
3. After connecting from the valve gap, reinstall it from left, right or backwards for installation.
4. The right picture is the sketch map of valve installation board of outdoor. Gas-side (low pressure) is the one upward, liquid side is the one downward.

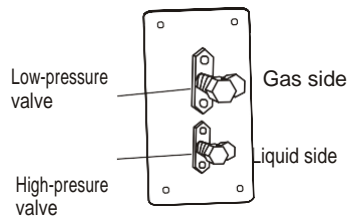

INSTALLATION

Pre-installation precautions

- Please confirm that the installation personnel are qualified in relevant installation service. If the air conditioner was installed by persons without special skills, normal operations would not be ensured, even the personal and estate safety would be affected.

User guideline

- The user's installation site should be provided with regular power supply in conformity with that indicated in nameplate of the air conditioner, and its voltage should be within a range 90 %-110 % of the rated voltage value.
- Power circuit should be equipped with protector, such as electricity leakage protector or air switch, which should possess a capacity greater than 1.5 times the maximum current value of the air conditioner.
- Never fail to adopt personal circuit and effectively-grounded socket compatible with the attached plug of the air conditioner. The attached plug is equipped with grounding pin, and it must not be modified as desired.
- Please adopt the fuse or circuit breaker prescribed in Installation Instructions.
- Only qualified electrician is allowed to carry out wiring tasks strictly according to electric safety requirements.
- Do ensure good earth of air conditioner, in other words, the main power switch of air conditioner must be connected to reliable ground wire.

Precautions

- The air conditioner should be installed securely; otherwise poor installation may lead to abnormal noises and vibration.
- Outdoor unit should be installed at a spot ensuring that its air outlet noises and hot exhaust will not violate your neighbors.

Unit body installation

Please confirm the indoor unit dimension according to the picture below M10 whorl is to be installed.(4 sets)

- ◆ please refer to the following for the center distance between the bolts M 10
 - ◆ whorl is used
 - ◆ please consult professional for your specific ceiling arrangement.
1. Dismantle scale of the ceiling.....please keep ceiling its level. Strengthen the beam to avoid vibration.
 2. Break the beam of the ceiling
 3. Strengthen the breaking point of the ceiling and reinforce the ceiling beam.
- ◆ After the main body hanging is finished, arrangement of pipe and line will be done in the ceiling. The direction of the pipe is determined after the installation location is chosen.If the ceiling has existed, please arrange the refrigerant pipe, drainage pipe, indoor and outdoor connecting line.
 - ◆ Installation of the hanging screw bolt

REFRIGERANT PIPE INSTALLATION

Pipe dimension and ways of installation

Outdoor pipe dimension and ways of install (in sequence of cooling capacity)

Pipe Material		Copper Pipe for Air Conditioner		
Model		14K-19K	23K-28K	30K-60K
Size(mm)	Liquid side	6.35(1/4inch)	9.52(3/8inch)	9.52(3/8inch)
	Gas side	12.7(1/2inch)	15.8(5/8inch)	19.05(3/4inch)

Conventional pipe, cooling capacity 14000-30000Btu/h	Allowed value
Longest pipe(L)	30m
Maximum height drop	Height drop between indoor and outdoor unit
	20m

Conventional pipe, cooling capacity \geq 30000Btu/h	Allowed value
Longest pipe (L)	50m
Maximum height drop	Height drop between indoor and outdoor unit H
	25m

Please refer to refrigerant pipe connection for detail

Allowed length and

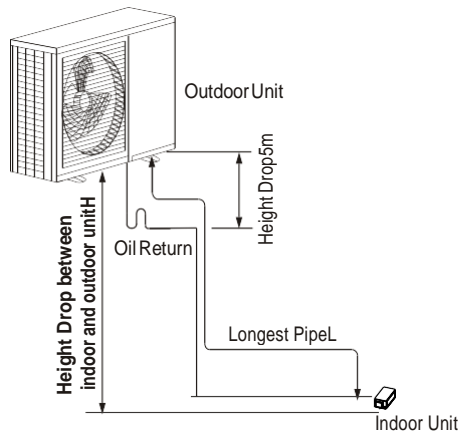

Remove objects and water

- Use high-pressure nitrogen to clean the pipe instead of outdoor refrigerant. Before installing refrigerant pipe, please clean the pipe in case of foreign objects.

Additional refrigerant charge

The additional charge is base on the diameter and length of outlet/inlet liquid type . This AC has been charged with that for 5m pipe, those beyond 5 m should recharge as follows.

Liquid pipe diameter	$\phi 1/4''$	$\phi 3/8''$	$\phi 1/2''$
Additional charge for 1m pipe(R410A)	0.022kg	0.054kg	0.110Kg
Additional charge for 1m pipe(R22)	0.020kg	0.050kg	0.080Kg

FIARIN

- ① Cut the refrigerant pipe off with pipe cutter.

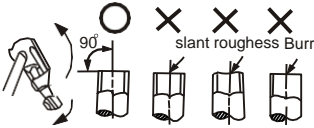

- ② Flaring after putting the pipe into connection nut.

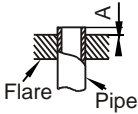

Outside Diameter	A mm	
	MAX	MIN
1/4"	8.7	8.3
3/8"	12.4	12.0
1/2"	15.8	15.4
5/8"	19.0	18.6
3/4"	23.3	22.9

Stop valve operation item

- Open the valve rod til to the position rod.
Do not try to open larger.
- Fasten the bonnet with spanner or similar tools.
- Fasten the bonnet of valve rod.
Liquid side(3/8 , 1/2): 1180N.c.m(120kgf.cm)
gas side(5/8 , 3/4): 1180N.c.m(120kgf.cm)

- When vacuum pump is used, each low-pressure valve must be manipulated as follow
Please refer to operation manual for the usage of manifold valve.

1. Connect the recharged hose to lower pressure valve junction (low/high pressure valve must be tightened.)
2. Connect the charged hose junction with vacuum pump.
3. Open the low pressure handler of manifold fully.
4. Start vacuumizing with vacuum pump. When vacuumizing begins, loosen the nut of low pressure valve a bit. Check if the air enters (noise of vacuum pump changes, the all-purpose meter indication change from negative to zero), then tighten the nut of connection pipe.
5. After vacuumizing finishing, tighten the low pressure handler of manifold valve fully and stop the vacuum pump. When vacuumizing is carried out for over 15 minutes, please confirm if the all-purpose meter points at -1.0×10^5 Pa (-76cmHg).
6. Open the high/low pressure valve fully.
7. Dismantle the recharged hose from charge gap of low pressure valve.
8. Tighten the bonnet of low-pressure valve.

Junction fixture

- Aim at connection pipe
fix the nut of connection pipe, then tighten] as the following diagram with spanner

▲ Notice

- According to installation conditions, overlarge wrenched torch will destroy the nut. (Unit. N.cm)

Outside diameter	Stengthen to fasten the torch
1/4"	1420~1720N cm (144~176kgf.cm)
3/8"	3270~3990N cm (333~407kgf.cm)
1/2"	4950~6030N cm (504~616kgf.cm)
5/8"	6180~7540N cm (630~770kgf.cm)
3/4"	9720~11860N cm (990~1210kgf.cm)

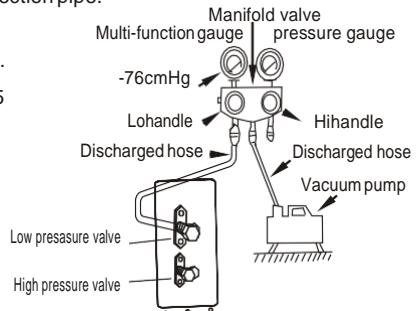
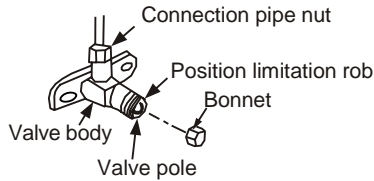
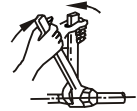

- The following figure only shows the assembly relationship of the indoor unit ,outdoor unit and refrigerant pipes.
- Please refer to the following figures to install.

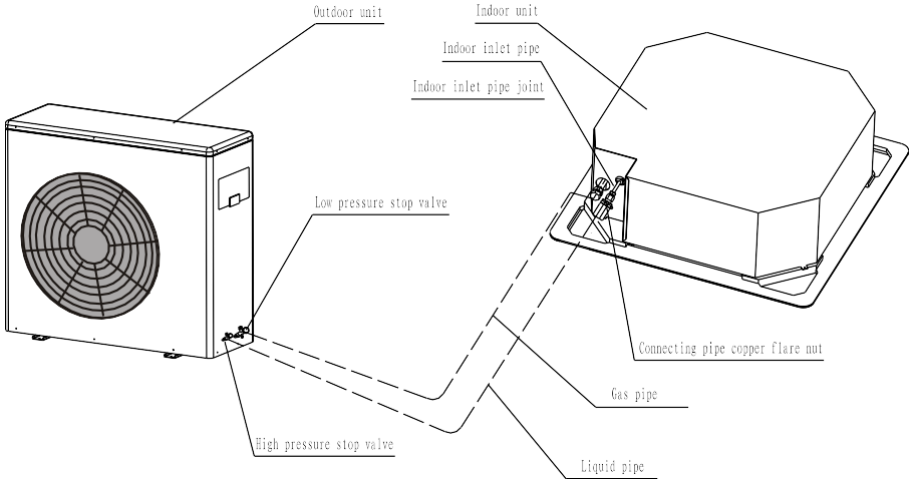

NOTE

- The throttle subassembly **has** been installed in the outdoor unit..
- Use two spanners to connect the pipe with indoor/outdoor pipes to avoid the copper pipe cracking.
- Please pay attention to the connection orientation when connecting.

AIR PURGING

Use a vacuum pump, to vacuum from the gas side refrigerant adding mouth of the outdoor unit.

Air and moisture remains inside the refrigeration system, may has the following bad effects:

- Rise of pressure inside the refrigeration system;
- Decrease of cooling (or *heating) effect;
- Moisture frozen and blocking the refrigeration system;
- Rusting of certain parts of the system

- Don't use the refrigerant of the outdoor unit to do the vacuum. (A certain volume of refrigerant had been added into the outdoor unit in factory.)

After connecting the indoor and outdoor units , it is necessary to exhaust the air inside the pipes completely as follows:

ELECTRIC WIRING

WARNING

Specified power cables should be used. Do not apply any pressure on the terminals used to connect.

Improper connection may cause fire.



Grounding must be properly done.

The grounding wire should be away from gas pipes, water pipes, telephone, lightning rods or other grounding wires. Improper grounding may cause electric shock.



Electric Wiring must be done by professionals. Use a separate circuit according to national regulations.



The temperature of refrigerant circuit will be high, please keep the interconnection cable away from the copper tube.

If the wiring capacity is not enough, electric shock or fire may occur.

If the supply cord is damaged, it must be replaced by the manufacturer or its service agent or a similarly qualified person in order to avoid a hazard

An all-pole disconnection switch having a contact separation of at least 3mm in all poles should be connected in fixed wiring.

CAUTION

Be sure to install Current Leakage Protection Switch. Or electric shock may occur. The appliance must be positioned so that the plug is accessible. The appliance shall be installed in accordance with national wiring regulations.

CAUTION

- Power cord is to be selected according to national regulations.
- Outdoor unit power cord should be selected and connected according to the outdoor unit installation manual.
- Wiring should be away from high temperature components, or the insulation layer of the wires may melt down.
- Use wire clamp to fix the wires and terminal block after connection.
- Control wire should be wrapped together with heat insulated refrigerant pipes.
- Connect the indoor unit to power only after the refrigerant has been vacuumed.
- Don't connect the power wire to the signal wire connection end.

■ Panel Wiring

Connect the Swing Motor terminal block according to cassette indoor unit wiring diagram.

■ Terminal Board Diagram

Please refer to cassette indoor unit wiring for the wiring.

Steps of external wiring connection

1. Remove air intake grille and electric box cover of indoor unit.
2. Remove access door of outdoor unit.
3. Connect the power supply connecting cable, the control connecting cable and defrost connecting cable between indoor and outdoor unit. (The defrost connecting cable is not applicable for heat pump models.) Please refer to the following pages for details.
4. Make sure the cables being fixed well with an effective anchorage after connecting.
5. Grounding work must be carried out for indoor and outdoor units.
6. Install the components removed back to the unit.

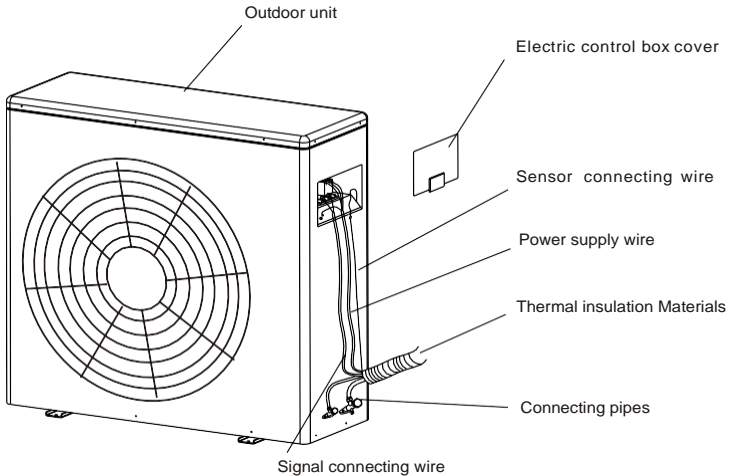

2. Binding treatment

Once the connecting wires have been properly connected, bind the connecting tubing, connecting wire and drain pipe by binding tapes

After binding treatment, the cross section is shown in the figure below:

Notice: Drain pipe must not be flattened during binding treatment.

Drain pipe outlet should be led to a place that can avoid affecting the environment.

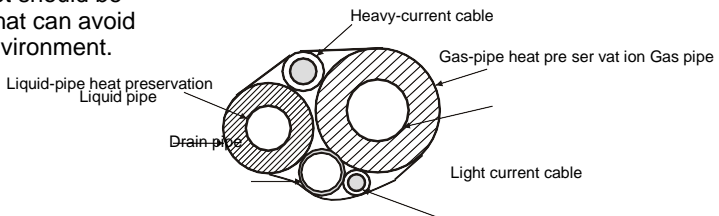

If situations as follow occur, please cut off the electric power before contacting the dealer

- open or close incorrectly
- fuse or electric leakage protector breaks for several times.
- Objects or water into the AC

3. External wiring diagrams

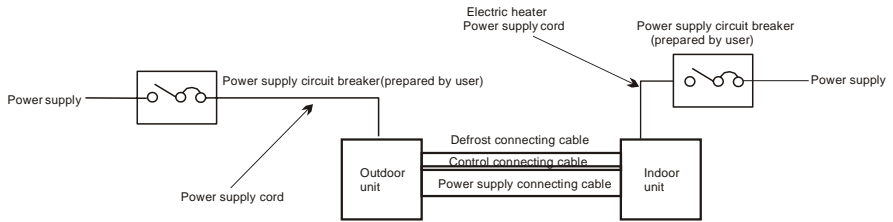

TEST RUN

■ Before testing

- Check if piping, drainage and external wiring have been finished correctly.
- Check if the power supply complies with requirements; if there is refrigerant leakage; if the all wires and cables are correctly connected and well fixed.

■ Function test

- After checking, energize your appliance and press the buttons on the control panel to see if the buttons function;
- If LCD screen displays normally.

■ Notes

- Please read this operating and installation instructions carefully.
- Do not let air in or refrigerant out during installing or reinstalling the appliance.
- Test run the air conditioner after finishing installation and keep the record .
- Type of fuse for controller of indoor unit is 50T, rated specification is T 10 A, 270V. Fuse for the whole unit is not supplied by the manufacturer, so the installer must employ a suitable fuse or other over-current protective device for the power supply circuit according to the maximum power input as required.
- The air conditioner operates safely when ambient static pressure is 0.8~1.05 standard atmosphere pressure.

Checks before operation

CAUTIONS

- Check that the wiring is not broken off or disconnected.
- Check that the air filter is installed. (Some air-conditioners have no air filters) Check that the outdoor unit air outlet or inlet is not blocked.

Before you clean the air conditioner, be sure to disconnect the power supply plug.

Clean the air filter

- The air filter can prevent the dust or other particulate from going inside. In case of blockage of the filter, the working efficiency of the air conditioner may greatly decrease. Therefore, the filter must be cleaned once two weeks during long time usage.
- If the air conditioner is positioned in a dust place, the cleaning frequency of the air filter must be increased.
- If the accumulated dust is too heavy to be cleaned, please replace the filter with a new one (replaceable air filter is an optional fitting).

■ Cassette Type

1. Open the air-in grill

Push the grill switches towards the middle simultaneously as indicated in sketch A. Then pull down the air-in grill.

Caution:

The control box cables, which are originally connected with the main body electrical terminators must be pulled off before doing as indicated below.

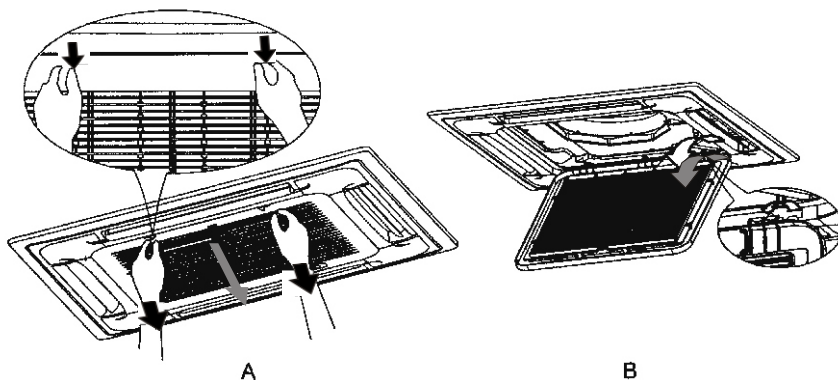

2. Take out the air-in grill (together with the air filter shown in Sketch B)

Pull the air-in grill down at 45° and lift it up to take out the grill.

3. Dismantle the air filter

4. Clean the air filter (Vacuum cleaner or pure water may be used to clean the air filter. If the dust accumulation is too heavy, please use soft brush and mild detergent to clean it and dry out in cool place).

ADJUSTING AIR FLOW DIRECTION

■ Cassette Type

While the unit is in operation, you can adjust the air flow louver to change the flow direction and naturalize the room temperature evenly. Thus you can enjoy it more comfortably.

1. Set the desired air flow direction.
Push the SWING button to adjust the louver to the desired position and push this button again to maintain the louver at this position.
2. Adjust the air flow direction automatically.
Push the SWING button, the louver will swing automatically..

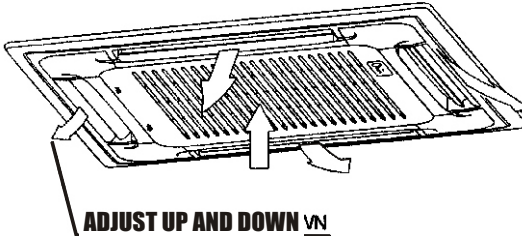

While this function is set, the swing fan of indoor unit runs; otherwise, the swing fan doesn't run. The swing scale of every side is 30°. When the air conditioner isn't in operation (including when TIMER ON is set), the SWING button will be disabled.

MAINTENANCE

▲WARNING

Before you clean the air conditioner, be sure to disconnect the power supply plug.

Cleaning the indoor unit and remote controller

▲CAUTIONS

- Use a dry cloth to wipe the indoor unit and remote controller.
- A cloth dampened with cold water may be used on the indoor unit if it is very dirty. Never use a damp cloth on the remote controller.
- Do not use a chemically-treated duster for wiping or leave such material on the unit for long, because it may damage or fade the surface of the unit.
- Do not use benzene, thinner, polishing powder, or similar solvents for cleaning. These may cause the plastic surface to crack or deform.

If you do not plan to use the unit for at least 1 month.

- (1) Operate the fan for about half a day to dry the inside of the unit.
- (2) Stop the air conditioner and disconnect power.
- (3) Remove the batteries from the remote controller.

IMPORTANT SAFETY INFORMATION

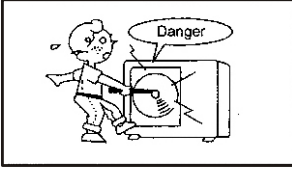

▲ CAUTION

Do not attempt to install this unit by yourself. This unit requires installation by qualified persons.

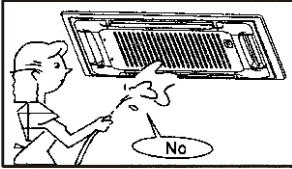

▲ DANGER

Do not attempt to service the unit yourself. This unit has no user serviceable components. Opening or removing the cover will expose you to dangerous voltage. Turn off the power supply will not prevent potential electric shock.

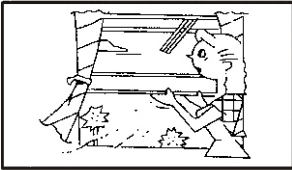

▲ DANGER

To avoid the risk of serious electrical shock, never sprinkle or spill water or liquid on unit.

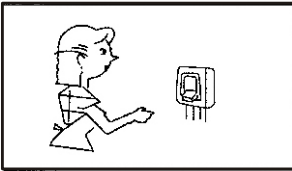

▲ WARNING

Ventilate the room regularly while the air conditioner is in use, especially if there is also a gas appliance in use in this room. Failure to follow these directions may result in a loss of oxygen in the room.

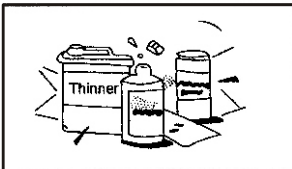

▲ WARNING

To prevent electric shock, turn off the power or disconnect the power supply plug before beginning any cleaning or other routine maintenance.

▲ WARNING

Do not use liquid cleaners or aerosol cleaners, use a soft and dry cloth for cleaning the unit. To avoid electric shock, never attempt to clean the units by sprinkling water.

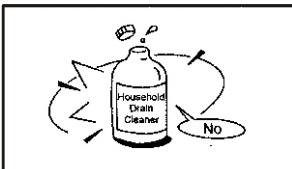

▲ NOTE

For proper performance, operate the unit in temperature and humidity ranges indicated in this owner's manual. If the unit is operated beyond these conditions, it may cause malfunctions of the unit or dew dripping from the unit.

REMOTE CONTROLLER

No.	Button	Function
1	▲ (TEMP UP)	Increase the temperature or time by 1 unit
2	▼ (TEMP DN)	Decrease the temperature or time by 1 unit
3	ON/OFF	To switch the conditioner on and off.
4	ECO	In cooling mode, press this button, the temperature will increase 2 °C on the base of setting temperature In heating mode, press this button, the temperature will decrease 2 °C on the base of setting temperature
5	MODE	To select the mode of operation
6	SLEEP	To activate the function SLEEP ”
7	FAN	To select the fan speed of auto/low/mid/high
8	SWING	To activate or deactivate of the movement of the “DEFLECTORS.”
9	HEALTHY	To switch - on /off HEALTHY funtion.It is a button which controls the ionizer or plasma generator only for inverter type.
10	TURBO	In cooling mode, press this button, the unit will give the maximum cooling temperature with 16 °C In heating mode, press this button, the unit will give the maximum heating temperature with 31 °C
11	DISPLAY	To switch on/off the LED display (if present)
12	TIMER	To set automatic switching-on/off

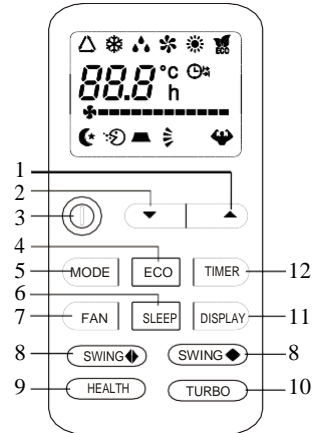

△ The outlooking and some function of remote control may vary according to the model.

△ The shape and position of buttons and indicators may vary according to the model, but their function is the same.

△ The unit confirms the correct reception of each press button with a beep.

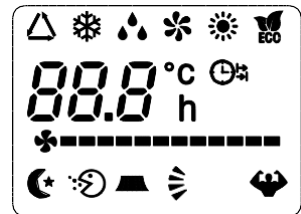

Remote control DISPLAY

Meaning of symbols on the liquid crystal display

No.	Symbols	Meaning	No.	Symbols	Meaning
1	△	FEEL mode indicator	10	✦-----	MIDDLE FAN SPEED indicator
2	❄	COOLING indicator	11	✦-----	HIGH FAN SPEED indicator
3	💧	DEHUMIDIFYING indicator	12	☾	SLEEP indicator
4	✦	FAN ONLY OPERATION indicator	13	⚡	SUPER indicator
5	☀	HEATING indicator	14	⌚	HEALTHY indicator
6	⌚	TIMER OFF indicator	15	ECO	ECO indicator
7	⌚	TIMER ON indicator	16	🔋	BATTERY indicator
8	✦-	AUTO FAN indicator	17	🔋	BATTERY indicator
9	✦---	LOW FAN SPEED indicator	18	00.0	CLOCK indicator

COOLING MODE

The cooling function allows the air conditioner to cool the room and at the same time reduces the humidity in the air.

To activate the cooling function (COOL), press the MODE button until the symbol ☀ appears on the display.

The cooling cycle is activated by setting the keys ▲ or ▼ at a temperature lower than that of the room.

To optimize the functioning of the conditioner, adjust the temperature (1), the speed (2) and the direction of the air flow (3) by pressing the keys indicated

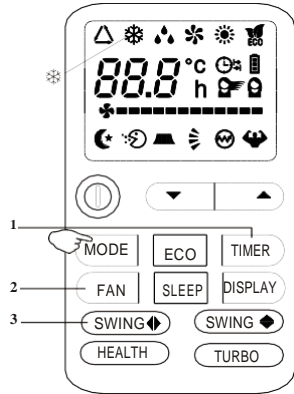

HEATING MODE

The heating function allows the air conditioner to produce hot air.

To activate the heating function (HEAT), press the

MODE button until the symbol ☀ appears on the display.

With the keys ▲ or ▼ set a temperature higher than that of the room..

To optimize the functioning of the conditioner adjust the temperature (1), the speed (2) and the direction of the air flow (3) by pressing the keys indicated

⚠ The appliance is fitted with a Hot Start function, which delays appliance to startup in a few seconds to ensure an immediate output of hot air.

⚠ In HEATING operation, the appliance can automatically activate a defrost cycle, which is essential to free the condenser from an excessive deposit of frost .This procedure usually lasts for 2-10 minutes during defrosting,fans stop operation. After defrosting ,it returns to HEATING mode automatically.

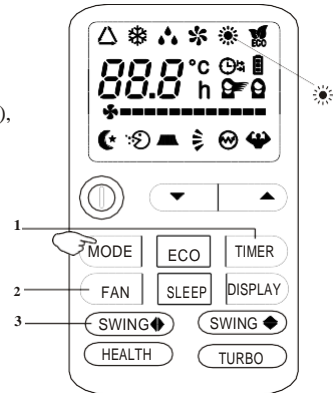

FAN MODE

The conditioner works in only ventilation.

To set the FAN mode , Press MODE untill ☀ appears in the display.

Which pressing FAN button the speed changes in the following sequence: LOW/ MEDIUM/HIGH /AUTO in FAN mode.

The remote control also stores the speed that was set in the previous mode of operation.

In FEEL mode (automatic) the air conditioner automatically chooses the fan speed and the mode of operation (COOLING or HEATING).

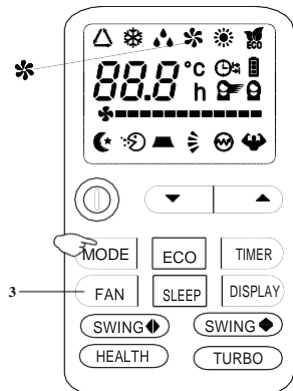

TIMER MODE----TIMER ON

To set the automatic switching on of the air conditioner.

To program the time start,the appliance should be off.

Press **TIMER** ,Set the temperature with pressing the key **▲** or **▼**Press **TIMER** Again , set the time with pressing the key **▲** or **▼**, Press the key more times till on the display you can read the time which passes between the programming and the timed start.

IMPORTANT!

Before proceeding with the timed start : program the working mode with the key **MODE**(2) and the fan speed with the key **FAN**(3) . Switch the conditioner off (with the key **ON/OFF**).

Note:To cancel the setted function ,press the **TIMER** button again.

Note:In case of power off,it is necessary to set **TIMER ON** again.

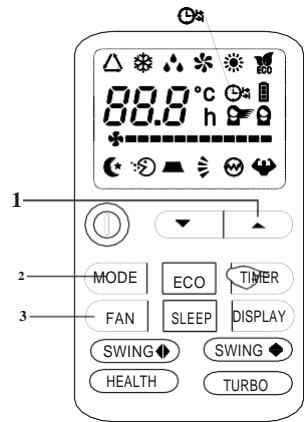

TIMER MODE----TIMER OFF

To set the automatic switching-off of the air conditioner.

The timed stop is programmed with the appliance on.

Press **TIMER** ,Set the time pressing the key **▲** or **▼**Press the key more times till on the display you can read the time which passes between the programming and the timed stop.

Note:To cancel the setted function, press the **TIMER** button again.

Note:In case of power off,it is necessary to set **TIMER OFF** again.

Note: While the time was right settled, the **TIMER** function of this remote(clock function) can set by half hours.

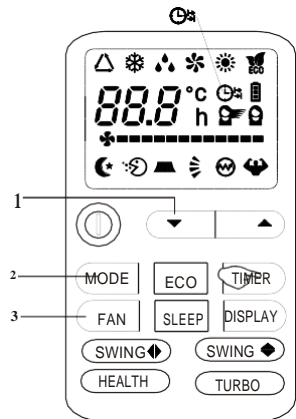

DRY MODE

This function reduces the humidity of the air to make the room more comfortable.

To set the **DRY** mode , Press **MODE** until **☁** appears in the display . An automatic function of alternating cooling cycles and air fan is activated.

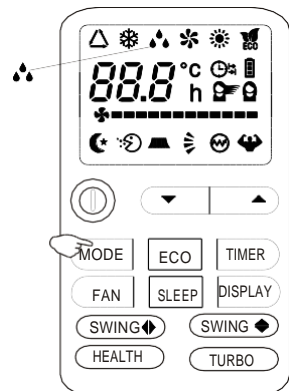

FEEL MODE

To activate the FEEL (automatic) mode of operation, press the MODE button on the remote control until the symbol  appears in the display. In the FEEL mode the fan speed and the temperature are set automatically according to the room temperature (tested by the probe which is incorporated in the indoor unit) to ensure user comfort.

Ambient temp	Operation mode	Auto temp.
< 20°C	HEATING (FOR HEAT PUMP TYPE) FAN (FOR COOL ONLY TYPE)	23°C
20°C~26°C	DRY	18°C
> 26°C	COOL	23°C

To optimize the working of the conditioner, adjust the $\pm 2^\circ\text{C}$ (1), the speed (2) and the direction of the air flow (3) by pressing the buttons indicated .

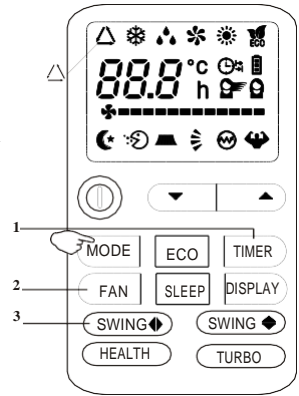

SLEEP MODE

To activate the SLEEP mode of operation, press the SLEEP button on the remote control until the symbol  (AUTOQUIET) appears in the display. The function SLEEP automatically adjusts the temperature to make the room more comfortable during the night sleep . In cooling or dry mode , the set temperature will automatically raise by 1 °C every 60 minutes, to achieve a total rise of 2 °C during the first 2 hours of work.

In heating mode the set temperature is gradually decreased by 2 °C during the first 2 hours of work.

After 10 hours running in sleep mode the air conditioner is switched off automatically.

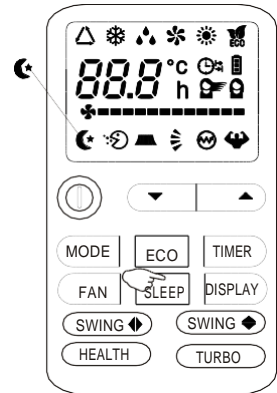

■ Remote controller handling procedure

Batteries replacing procedure

Following cases signify dead cells. Replace the dead batteries with new ones.

- Receiving sound is not emitted from the unit when signal is transmitted.
- Indicator becomes indistinct.

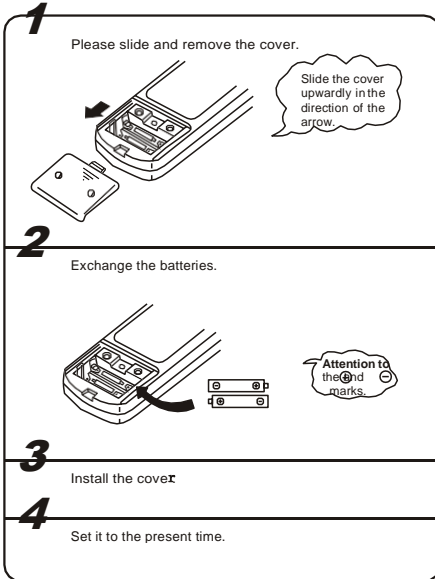

NOTE

- Do not use an old battery together with a new one.
- Remove cells when the remote controller is not used for a long period.
- The life of a cell made in conformity to JIS or IEC is 6 to 12 months in normal use. If it is used longer or an unspecified cell is used, a liquid leaks from the cell, causing the remote controller inoperative.
- Guideline of the life time is printed on the battery. The battery life may be shorter than that of the air conditioner depending on the date of manufacture.
- However, the battery may be alive even after the nominal life time expired.

Note of remote controller handling

- A place with high temperature such as near an electric carpet or a stove.



- A place unprotected from direct sunlight or strong lighting.



- It will be damaged if fallen. Be careful.



- Do not put obstacles between the remote controller and the unit.



- Protect the remote controller from being splashed with water, etc.



- Do not put weights on the remote controller.



■ Air flow direction adjustment procedure

Adjusting air flow direction

- Up/down direction can be adjusted by using the AIRFLOW button on the remote controller. This button, each time pressed, changes the mode in the following sequence:

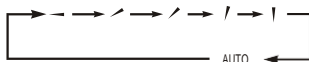

- push the LOUVER button, changes the mode to swing louver. Push the button, to stop swing.

NOTE

- When the room temperature controller (thermostat) trips in the heating mode or when the defrosting operation is conducted, the blow flap changes automatically to the horizontal position.
- When the heating operation has just started and the room temperature is still low, it may take a little time before the flap moves to the above sway operation angle.
- The flap may stop at the tilted down-blow position during the "Sway operation" in the heating mode.

■ About TIMER operation

About Amenity reservation

Amenity reservation function is provided to start the operation a little earlier so that the room temperature is near the optimum temperature at the timer ON time in case of starting the operation by TIMER ON/OFF.

● Mechanism

- Checking of the room temperature starts 60 minutes ahead of the timer ON time. Depending on the temperature at that time, operation starts 5 to 60 minutes ahead of the timer ON time.
- Amenity reservation is the function only for COOL and HEAT operation mode (including AUTO). It does not actuate in DRY mode.

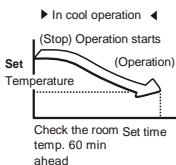

About SLEEP Operation

When the SLEEP operation is selected, the room temperature is automatically controlled with elapsed time so that the room isn't too cool during cooling or too warm during heating.

- During cooling and dry: Present temperature is raised 1 in an hour (when the timer is set), and 2 raise in two hours. Then the temperature doesn't change ever.
- During heating: Present temperature is lowered 1 in an hour (when the timer is set), and 2 lower in two hours. Then the temperature doesn't change ever.

■ About FAN SPEED

- Capacity of the air conditioner can be selected by your choice. During heating or cooling.

Operation capacity by your choice	FAN SPEED
Set automatically by microcomputer	AUTO
Powerful operation with high capacity	HI
Standard operation	MED
Energy-saving operation	Lo

■ About power-off memory function

- When the air conditioner disconnect the power suddenly, restart it, the air conditioner operates at the mode it did before power suddenly failed.
- The wire controll don't have this function

TROUBLESHOOTING

The display content of indoor LED	The display content of outdoor LED	The definition of failure or protection
E0	E01	Bus communication fault of indoor and outdoor unit
EC	E03	Inverter module communication fault of outdoor unit
E4	E04	Phase order protection fault(main pcb)
E7	E05	Outdoor temperature sensor fault
E4	E06	Temperature sensor fault in the middle part of condenser
E3	E07	Defrost temperature sensor fault
E4	E12	Back temperature sensor fault(ts)
E8	E13	Exhaust temperature sensor fault of compressor
E4	E21	Reversing fault of 4-way valve (heating mode)
EE	E23	EEPROM fault (outdoor unit E2 fault)
E4	E30	The unit type is wrong chose by the outdoor dial-up
E1	E32	Indoor temperature sensor Ta
E2	E33	Inner disc tube temperature sensor Tm
E4	E34	High pressure switch fault (when rate is 0, open circuit)
E4	E35	Low pressure switch fault (when rate is 0, open circuit)
P1	P01	low -voltage protection
P0	P03	Inverter module protection
P3	P04	High pressure switch protection
P4	P09	Inverter compressor exhaust high temperature protection
P6	P12	Condenser high temperature protection
P2	P13	Inverter compressor current protection
P3	P21	Low pressure switch protection
P3	P26	IPM module overcurrent protection
P3	P27	IPM module low voltage protection
P3	P28	IPM module high voltage protection
P5	P31	Indoor coiler temperature protection
P8	P33	Too high or too low protection for outdoor temperature
P3	P34	Drive radiator temperature protection